

Declaration

BTL represents to the client that testing is done in accordance with standard procedures as applicable and that test instruments used has been calibrated with standards traceable to international standard(s) and/or national standard(s).

BTL's reports apply only to the specific samples tested under conditions. It is manufacture's responsibility to ensure that additional production units of this model are manufactured with the identical electrical and mechanical components. **BTL** shall have no liability for any declarations, inferences or generalizations drawn by the client or others from **BTL** issued reports.

BTL's report must not be used by the client to claim product certification, approval, or endorsement by NVLAP, NIST, or any agency of the Federal Government.

This report is the confidential property of the client. As a mutual protection to the clients, the public and **BTL-self**, extracts from the test report shall not be reproduced except in full with **BTL's** authorized written approval.

BTL's laboratory quality assurance procedures are in compliance with the **ISO Guide 17025** requirements, and accredited by the conformity assessment authorities listed in this test report.

Limitation

For the use of the authority's logo is limited unless the Test Standard(s)/Scope(s)/Item(s) mentioned in this test report is (are) included in the conformity assessment authorities acceptance respective.

Table of Contents	Page
REPORT ISSUED HISTORY	4
1 . CERIFICATION	5
2 . SUMMARY OF TEST RESULTS	6
2.1 TEST FACILITY	7
2.2 MEASUREMENT UNCERTAINTY	7
3 . GENERAL INFORMATION	8
3.1 GENERAL DESCRIPTION OF EUT	8
3.2 DESCRIPTION OF TEST MODES	8
3.3 EUT OPERATING CONDITIONS	8
3.4 BLOCK DIAGRAM SHOWING THE CONFIGURATION OF SYSTEM TESTED	9
3.5 DESCRIPTION OF SUPPORT UNITS	10
4 . EMC EMISSION TEST	11
4.1 CONDUCTED EMISSION MEASUREMENT	11
4.1.1 POWER LINE CONDUCTED EMISSION	11
4.1.2 MEASUREMENT INSTRUMENTS LIST	11
4.1.3 TEST PROCEDURE	12
4.1.4 DEVIATION FROM TEST STANDARD	12
4.1.5 TEST SETUP	12
4.1.6 TEST RESULTS	12
4.2 RADIATED EMISSION MEASUREMENT	19
4.2.1 LIMITS OF RADIATED EMISSION MEASUREMENT	19
4.2.2 MEASUREMENT INSTRUMENTS LIST	20
4.2.3 TEST PROCEDURE	21
4.2.4 DEVIATION FROM TEST STANDARD	21
4.2.5 TEST SETUP	22
4.2.6 TEST RESULTS-BELOW 1GHZ	22
4.2.7 TEST RESULTS-ABOVE 1GHZ	35

REPORT ISSUED HISTORY

Issued No.	Description	Issued Date
BTL-FCCE-1-1703C091	Original Issue.	May 18, 2017

1. CERIFICATION

Equipment : IP Phone
Brand Name : Fanvil
Model Name : X4
Applicant : Fanvil Technology Co.Ltd
Manufacturer: Fanvil Technology Co.Ltd
Address : 3F, Block A, Gaoxinqi Building, Anhua Industrial Park, Qianjin 1st Rd. 35th
Dist., Bao'An, Shenzhen, 518101, China
Factory : Fanvil Technology Co.Ltd
Address : 3F, Block A, Gaoxinqi Building, Anhua Industrial Park, Qianjin 1st Rd. 35th
Dist., Bao'An, Shenzhen, 518101, China
Date of Test : Mar. 13, 2017 ~ May. 17, 2017
Test Sample : Engineering Sample
Standard(s) : FCC Part 15, Subpart B
ANSI C63.4-2014

The above equipment has been tested and found compliance with the requirement of the relative standards by BTL Inc.

The test data, data evaluation, and equipment configuration contained in our test report (Ref No. BTL-FCCE-1-1703C091) were obtained utilizing the test procedures, test instruments, test sites that has been accredited by the Authority of TAF according to the ISO-17025 quality assessment standard and technical standard(s).

2. SUMMARY OF TEST RESULTS

Test procedures according to the technical standard(s):

EMC Emission				
Standard(s)	Test Item	Limit	Judgment	Remark
FCC Part15, Subpart B ANSI C63.4-2014	Conducted Emission	Class B	PASS	
	Radiated emission Below 1 GHz	Class B	PASS	
	Radiated emission Above 1 GHz	Class B	PASS	NOTE(2)

NOTE:

- (1) " N/A" denotes test is not applicable to this device.
- (2) The EUT's max operating frequency is 166MHz which does exceed 108 MHz, so the test will be performed.

2.1 TEST FACILITY

The test facilities used to collect the test data in this report is at the location of No. 68-1, Ln. 169, Sec.2, Datong Rd., Xizhi Dist., New Taipei City 221, Taiwan

2.2 MEASUREMENT UNCERTAINTY

Where relevant, the following measurement uncertainty levels have been estimated for tests performed on the EUT as specified in CISPR 16-4-2. The BTL measurement uncertainty is less than the CISPR 16-4-2 U_{cispr} requirement.

The reported uncertainty of measurement $y \pm U$, where expanded uncertainty U is based on a standard uncertainty multiplied by a coverage factor of $k=2$, providing a level of confidence of approximately **95%**.

A. Conducted Measurement :

Test Site	Method	Measurement Frequency Range	U, (dB)
C05	CISPR	150 kHz~30MHz	3.06

B. Radiated Measurement :

Test Site	Method	Measurement Frequency Range	Ant. H / V	U, (dB)
CB11 (3m)	CISPR	30 MHz ~ 200 MHz	V	4.04
		30 MHz ~ 200 MHz	H	3.76
		200 MHz ~ 1, 000 MHz	V	4.24
		200 MHz ~ 1, 000 MHz	H	3.84

Test Site	Method	Measurement Frequency Range	Ant. H / V	U, (dB)
CB11 (3m)	CISPR	1GHz ~ 6GHz	V	4.46
		1GHz ~ 6GHz	H	4.40

Note: Unless specifically mentioned, the uncertainty of measurement has not been taken into account to declare the compliance or non-compliance to the specification.

3. GENERAL INFORMATION

3.1 GENERAL DESCRIPTION OF EUT

Equipment	IP Phone
Brand Name	Fanvil
Model Name	X4
Model Difference	N/A
Power Source	1)DC Voltage supplied from AC/DC adapter. 2)Supplied from PoE.
Power Rating	1)I/P: 100-240V~50/60Hz O/P: DC 5V600mA 2)DC 48V

Note:

1. For a more detailed features description, please refer to the manufacturer’s specifications or the user's manual.

3.2 DESCRIPTION OF TEST MODES

To investigate the maximum EMI emission characteristics generated from EUT, the test system was pre-scanning tested base on the consideration of following EUT operation mode or test configuration mode which possible have effect on EMI emission level. Each of these EUT operation mode(s) or test configuration mode(s) mentioned above was evaluated respectively.

Pretest Mode	Description
Mode 1	Handfree
Mode 2	Handset
Mode 3	Earphone

For Conducted Test	
Final Test Mode	Description
Mode 1	Handfree
Mode 2	Handset
Mode 3	Earphone

For Radiated Test	
Final Test Mode	Description
Mode 1	Handfree
Mode 2	Handset
Mode 3	Earphone

3.3 EUT OPERATING CONDITIONS

The EUT exercise program used during radiated and/or conducted emission measurement was designed to exercise the various system components in a manner similar to a typical use.

3.4 BLOCK DIAGRAM SHOWING THE CONFIGURATION OF SYSTEM TESTED Adapter

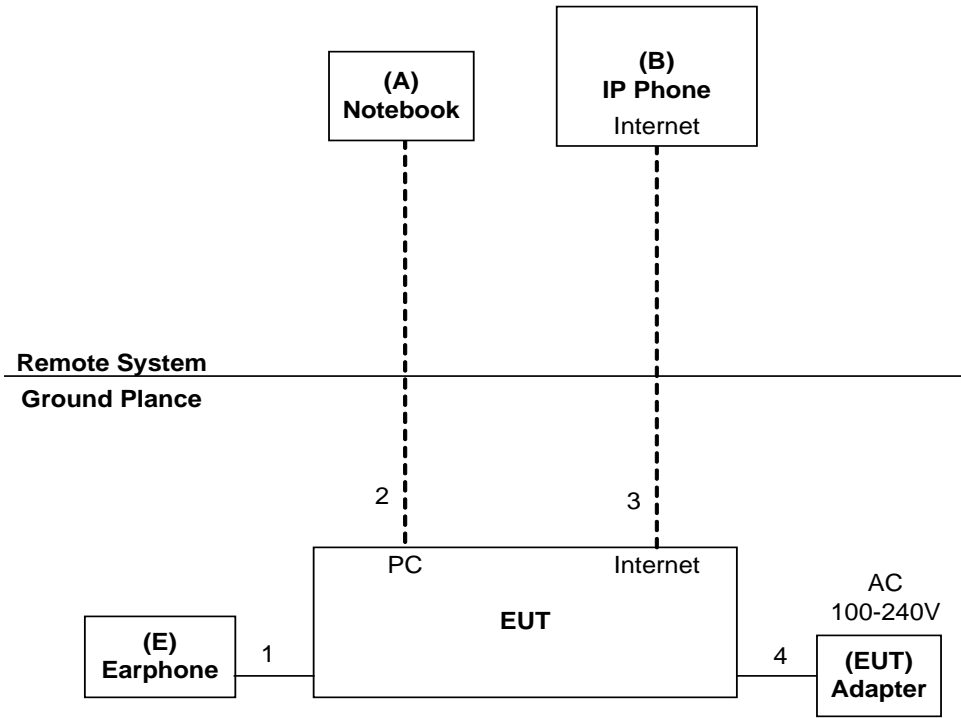

PoE

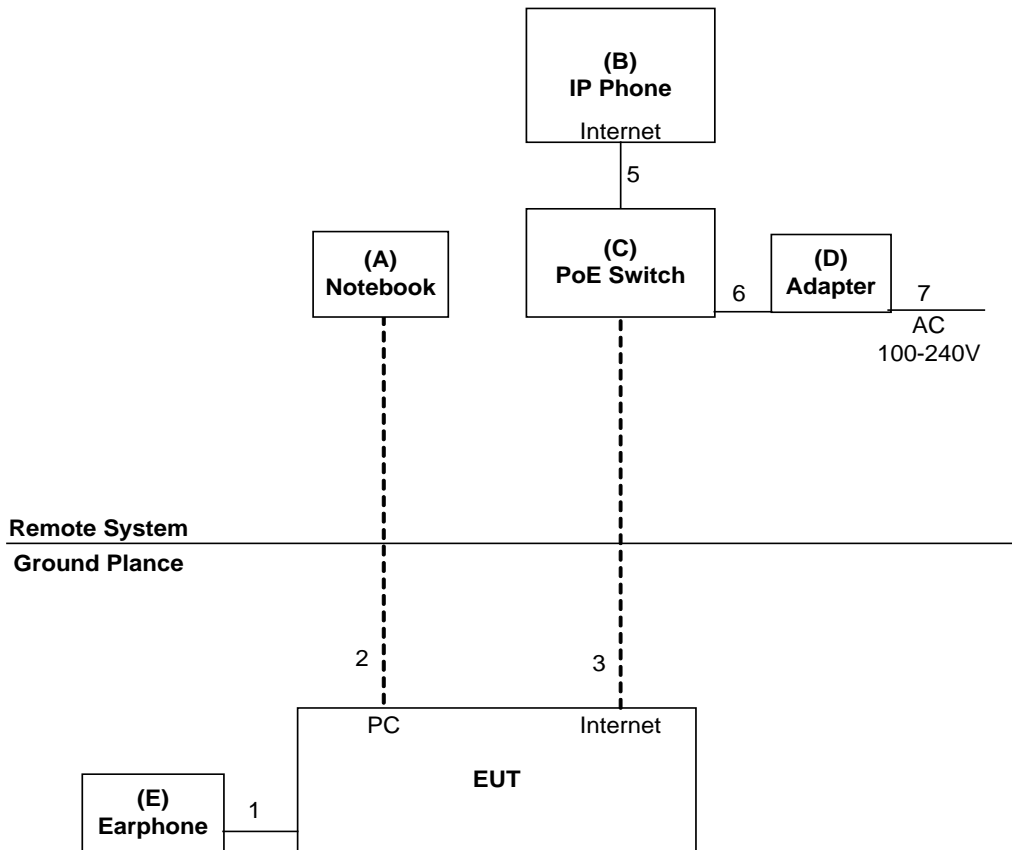

3.5 DESCRIPTION OF SUPPORT UNITS

The EUT has been tested as an independent unit together with other necessary accessories or support units. The following support units or accessories were used to form a representative test configuration during the tests.

Item	Equipment	Mfr/Brand	Model/Type No.	FCC ID	Series No.
A	Notebook	Lenovo	G40	DOC	YB09261386
B	IP Phone	Fanvil	X3SP	N/A	1000HF7371004260
C	PoE Switch	Fanvil	DGS-1008P/Dlink	N/A	N/A
D	Adapter	Leader	NU60-F4B0125-I1NN	N/A	N/A
E	Earphone	Fanvil	A310QD	N/A	N/A

Item	Shielded Type	Ferrite Core	Length	Note
1	NO	NO	1m	RJ11 Cable
2	NO	NO	10m	RJ45 Cable
3	NO	NO	10m	RJ45 Cable
4	NO	NO	1.5m	DC Cable
5	NO	NO	1.8m	RJ45 Cable
6	NO	YES	1.5m	DC Cable
7	NO	NO	1.8m	AC Cable

4. EMC EMISSION TEST

4.1 CONDUCTED EMISSION MEASUREMENT

4.1.1 POWER LINE CONDUCTED EMISSION (FREQUENCY RANGE 150KHZ-30MHZ)

FREQUENCY (MHz)	Class A (dBuV)		Class B (dBuV)	
	Quasi-peak	Average	Quasi-peak	Average
0.15 -0.5	79.00	66.00	66 - 56 *	56 - 46 *
0.50 -5.0	73.00	60.00	56.00	46.00
5.0 -30.0	73.00	60.00	60.00	50.00

Note:

- (1) The tighter limit applies at the band edges.
- (2) The limit of " * " marked band means the limitation decreases linearly with the logarithm of the frequency in the range.
- (3) The test result calculated as following:
 Measurement Value = Reading Level + Correct Factor
 Correct Factor = Insertion Loss + Cable Loss + Attenuator Factor(if use)
 Margin Level = Measurement Value - Limit Value

4.1.2 MEASUREMENT INSTRUMENTS LIST

Item	Kind of Equipment	Manufacturer	Type No.	Serial No.	Calibrated until
1	TWO-LINE V-NETWORK	R&S	ENV216	101050	Feb. 01, 2018
2	Test Cable	TIMES	CFD300-NL	C05	Jun. 13, 2017
3	EMI Test Receiver	R&S	ESR3	101854	May 12, 2018
4	Measurement Software	EZ	EZ_EMG (Version NB-03A)	N/A	N/A

Remark: "N/A" denotes no model name, serial no. or calibration specified.
 All calibration period of equipment list is one year.

4.1.3 TEST PROCEDURE

- a. The EUT was placed 0.8 meters from the horizontal ground plane with EUT being connected to the power mains through a line impedance stabilization network (LISN). All other support equipments powered from additional LISN(s). The LISN provide 50 Ohm/ 50uH of coupling impedance for the measuring instrument.
- b. Interconnecting cables that hang closer than 40 cm to the ground plane shall be folded back and forth in the center forming a bundle 30 to 40 cm long.
- c. I/O cables that are not connected to a peripheral shall be bundled in the center. The end of the cable may be terminated, if required, using the correct terminating impedance. The overall length shall not exceed 1 m.
- d. LISN at least 80 cm from nearest part of EUT chassis.
- e. For the actual test configuration, please refer to the related Item –EUT Test Photos.
- f. First the whole spectrum of emission caused by equipment under test(EUT) is recorded with Detector set to peak. Peak value recorded in table if the margin from QP Limit is larger than 2dB, otherwise, QP value is recorded, Measuring frequency range from 150KHz to 30MHz.

4.1.4 DEVIATION FROM TEST STANDARD

No deviation

4.1.5 TEST SETUP

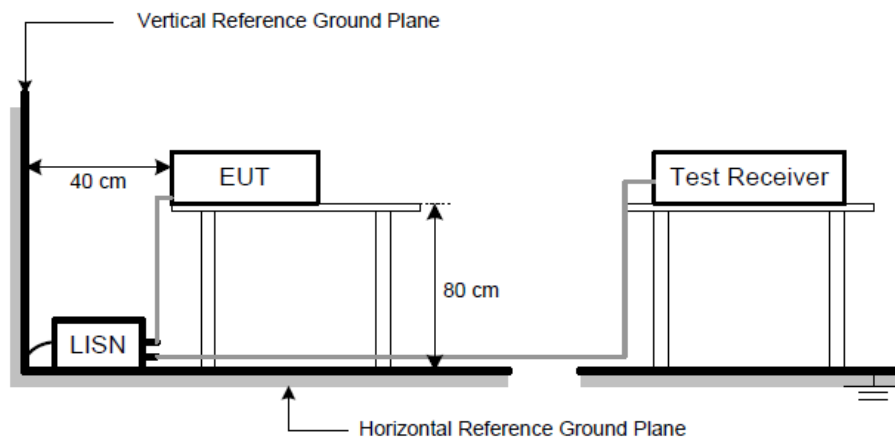

4.1.6 TEST RESULTS

Remark

- (1) Reading in which marked as QP means measurements by using are Quasi-Peak Mode with Detector BW=9KHz; SPA setting in RBW=10KHz,VBW =10KHz, Swp. Time = 0.3 sec./MHz. Reading in which marked as AV means measurements by using are Average Mode with instrument setting in RBW=10KHz,VBW=10KHz, Swp. Time =0.3 sec./MHz.
- (2) All readings are QP Mode value unless otherwise stated AVG in column of 『Note』. If the QP Mode Measured value compliance with the QP Limits and lower than AVG Limits, the EUT shall be deemed to meet both QP & AVG Limits and then only QP Mode was measured, but AVG Mode didn't perform. In this case, a “ * ” marked in AVG Mode column of Interference Voltage Measured.

EUT	IP Phone	Model Name	X4
Temperature	24°C	Relative Humidity	60%
Test Voltage	AC 120V/60Hz	Phase	Line
Test Mode	Handfree		
Note	Adapter		
Test Engineer	Pike Lee		

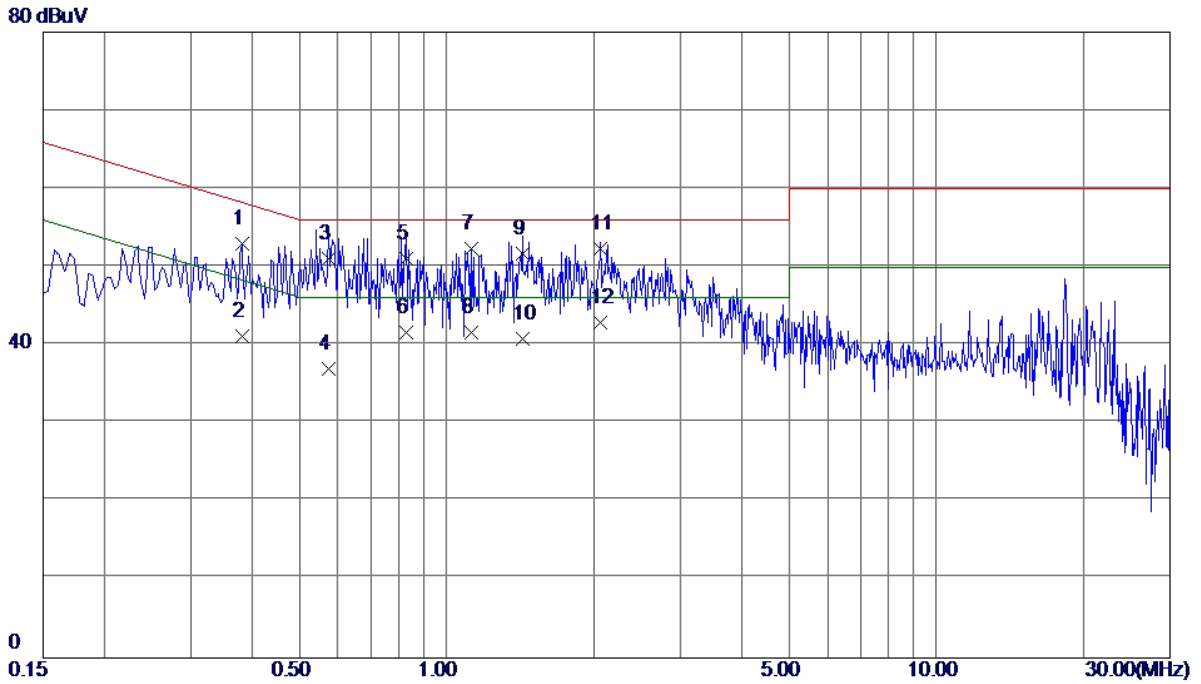

No.	Freq. MHz	Reading Level dBuV	Correct Factor dB	Measurement dBuV	Limit dBuV	Margin dB	Detector
1	0.3820	43.32	9.58	52.90	58.24	-5.34	QP
2	0.3820	31.50	9.58	41.08	48.24	-7.16	AVG
3	0.5740	41.30	9.70	51.00	56.00	-5.00	QP
4	0.5740	27.30	9.70	37.00	46.00	-9.00	AVG
5	0.8260	41.20	9.82	51.02	56.00	-4.98	QP
6	0.8260	31.80	9.82	41.62	46.00	-4.38	AVG
7	1.1220	42.54	9.85	52.39	56.00	-3.61	QP
8	1.1220	31.80	9.85	41.65	46.00	-4.35	AVG
9	1.4260	41.80	9.95	51.75	56.00	-4.25	QP
10	1.4260	30.80	9.95	40.75	46.00	-5.25	AVG
11	2.0620	42.29	10.04	52.33	56.00	-3.67	QP
12 *	2.0620	32.77	10.04	42.81	46.00	-3.19	AVG

EUT	IP Phone	Model Name	X4
Temperature	24°C	Relative Humidity	60%
Test Voltage	AC 120V/60Hz	Phase	Neutral
Test Mode	Handfree		
Note	Adapter		
Test Engineer	Pike Lee		

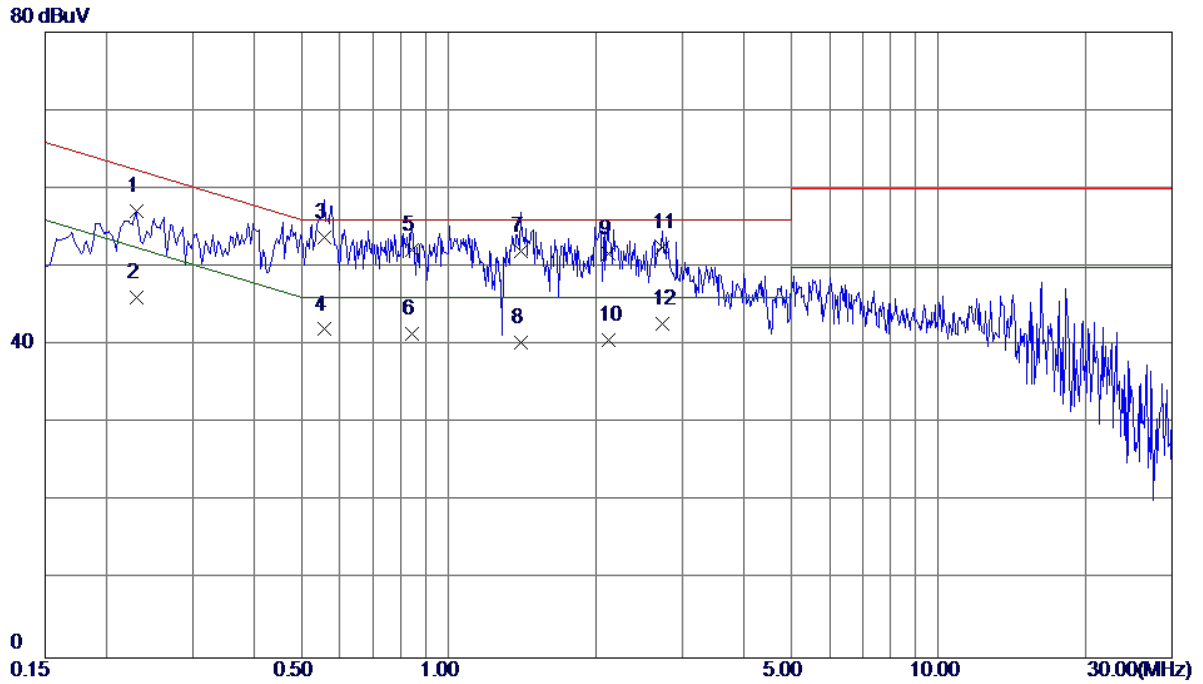

No.	Freq. MHz	Reading Level dBuV	Correct Factor dB	Measurement dBuV	Limit dBuV	Margin dB	Detector
1	0.2300	47.49	9.57	57.06	62.45	-5.39	QP
2	0.2300	36.50	9.57	46.07	52.45	-6.38	AVG
3 *	0.5580	44.28	9.50	53.78	56.00	-2.22	QP
4	0.5580	32.50	9.50	42.00	46.00	-4.00	AVG
5	0.8420	42.49	9.67	52.16	56.00	-3.84	QP
6	0.8420	31.79	9.67	41.46	46.00	-4.54	AVG
7	1.4020	42.30	9.77	52.07	56.00	-3.93	QP
8	1.4020	30.50	9.77	40.27	46.00	-5.73	AVG
9	2.1180	41.80	9.84	51.64	56.00	-4.36	QP
10	2.1180	30.80	9.84	40.64	46.00	-5.36	AVG
11	2.7340	42.58	9.95	52.53	56.00	-3.47	QP
12	2.7340	32.80	9.95	42.75	46.00	-3.25	AVG

EUT	IP Phone	Model Name	X4
Temperature	24°C	Relative Humidity	60%
Test Voltage	AC 120V/60Hz	Phase	Line
Test Mode	Handset		
Note	Adapter		
Test Engineer	Pike Lee		

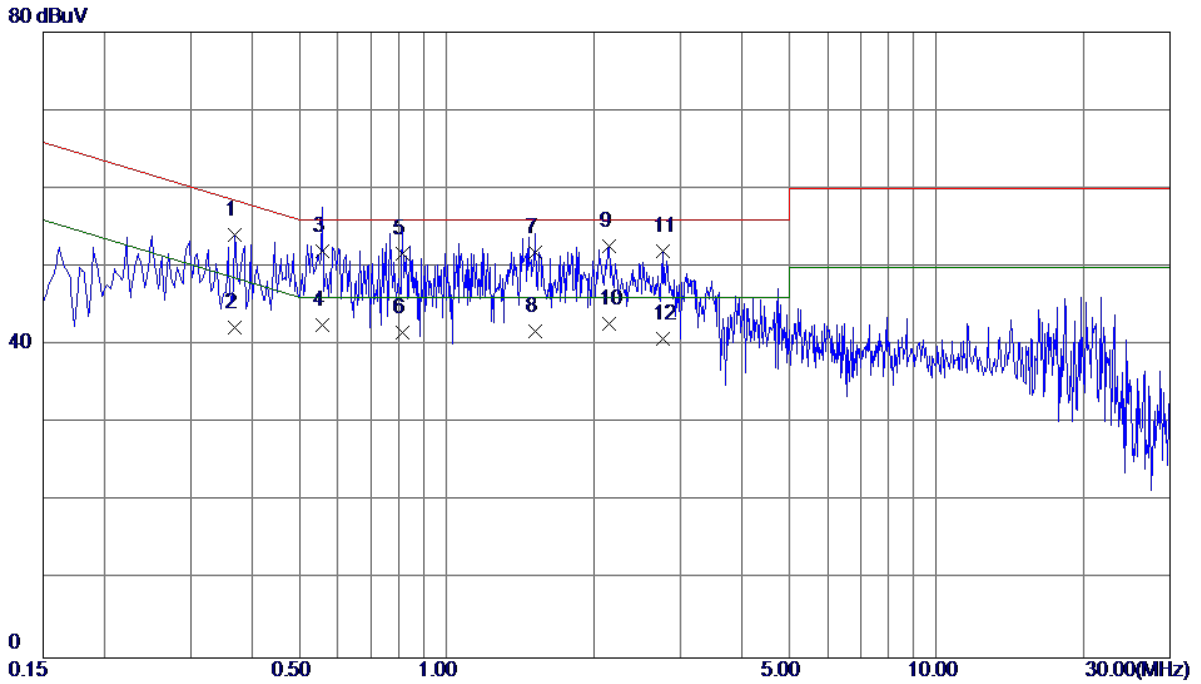

No.	Freq. MHz	Reading Level dBuV	Correct Factor dB	Measurement dBuV	Limit dBuV	Margin dB	Detector
1	0.3700	44.48	9.58	54.06	58.50	-4.44	QP
2	0.3700	32.60	9.58	42.18	48.50	-6.32	AVG
3	0.5580	42.30	9.70	52.00	56.00	-4.00	QP
4	0.5580	32.85	9.70	42.55	46.00	-3.45	AVG
5	0.8139	41.80	9.82	51.62	56.00	-4.38	QP
6	0.8139	31.80	9.82	41.62	46.00	-4.38	AVG
7	1.5140	41.89	9.98	51.87	56.00	-4.13	QP
8	1.5140	31.80	9.98	41.78	46.00	-4.22	AVG
9	2.1420	42.50	10.07	52.57	56.00	-3.43	QP
10 *	2.1420	32.61	10.07	42.68	46.00	-3.32	AVG
11	2.7700	41.72	10.25	51.97	56.00	-4.03	QP
12	2.7700	30.50	10.25	40.75	46.00	-5.25	AVG

EUT	IP Phone	Model Name	X4
Temperature	24°C	Relative Humidity	60%
Test Voltage	AC 120V/60Hz	Phase	Neutral
Test Mode	Handset		
Note	Adapter		
Test Engineer	Pike Lee		

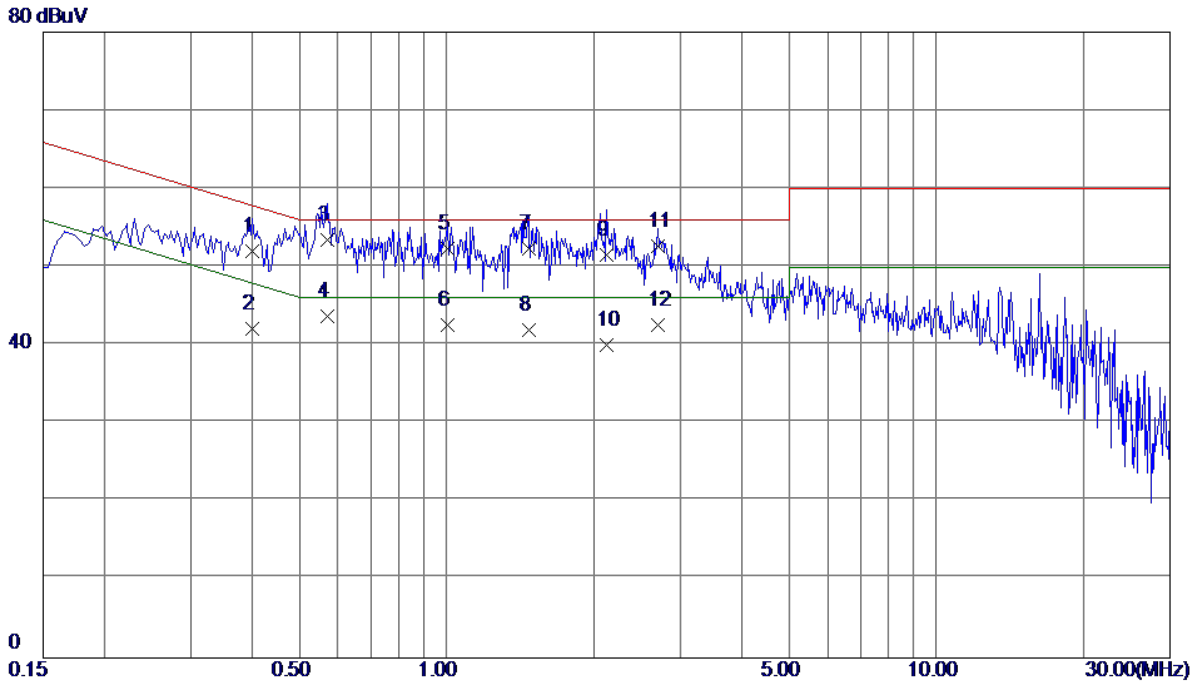

No.	Freq. MHz	Reading Level dBuV	Correct Factor dB	Measure ment dBuV	Limit dBuV	Margin dB	Detector
1	0.4020	42.50	9.48	51.98	57.81	-5.83	QP
2	0.4020	32.60	9.48	42.08	47.81	-5.73	AVG
3	0.5700	43.98	9.50	53.48	56.00	-2.52	QP
4 *	0.5700	34.20	9.50	43.70	46.00	-2.30	AVG
5	1.0020	42.60	9.74	52.34	56.00	-3.66	QP
6	1.0020	32.80	9.74	42.54	46.00	-3.46	AVG
7	1.4700	42.50	9.77	52.27	56.00	-3.73	QP
8	1.4700	32.10	9.77	41.87	46.00	-4.13	AVG
9	2.1260	41.61	9.84	51.45	56.00	-4.55	QP
10	2.1260	30.21	9.84	40.05	46.00	-5.95	AVG
11	2.6940	42.70	9.94	52.64	56.00	-3.36	QP
12	2.6940	32.60	9.94	42.54	46.00	-3.46	AVG

EUT	IP Phone	Model Name	X4
Temperature	24°C	Relative Humidity	60%
Test Voltage	AC 120V/60Hz	Phase	Line
Test Mode	Earphone		
Note	Adapter		
Test Engineer	Pike Lee		

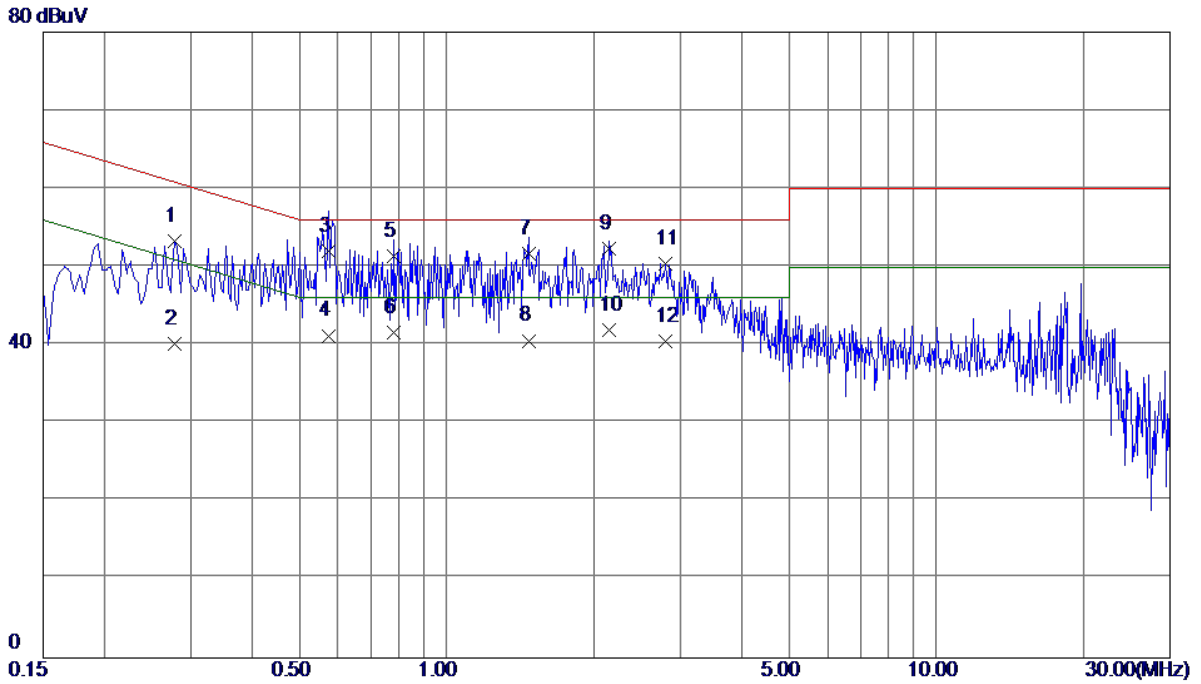

No.	Freq. MHz	Reading Level dBuV	Correct Factor dB	Measurement dBuV	Limit dBuV	Margin dB	Detector
1	0.2779	43.75	9.58	53.33	60.88	-7.55	QP
2	0.2779	30.60	9.58	40.18	50.88	-10.70	AVG
3	0.5740	42.30	9.70	52.00	56.00	-4.00	QP
4	0.5740	31.50	9.70	41.20	46.00	-4.80	AVG
5	0.7820	41.50	9.80	51.30	56.00	-4.70	QP
6	0.7820	31.80	9.80	41.60	46.00	-4.40	AVG
7	1.4700	41.70	9.96	51.66	56.00	-4.34	QP
8	1.4700	30.60	9.96	40.56	46.00	-5.44	AVG
9 *	2.1460	42.30	10.08	52.38	56.00	-3.62	QP
10	2.1460	31.90	10.08	41.98	46.00	-4.02	AVG
11	2.7980	40.23	10.25	50.48	56.00	-5.52	QP
12	2.7980	30.20	10.25	40.45	46.00	-5.55	AVG

EUT	IP Phone	Model Name	X4
Temperature	24°C	Relative Humidity	60%
Test Voltage	AC 120V/60Hz	Phase	Neutral
Test Mode	Earphone		
Note	Adapter		
Test Engineer	Pike Lee		

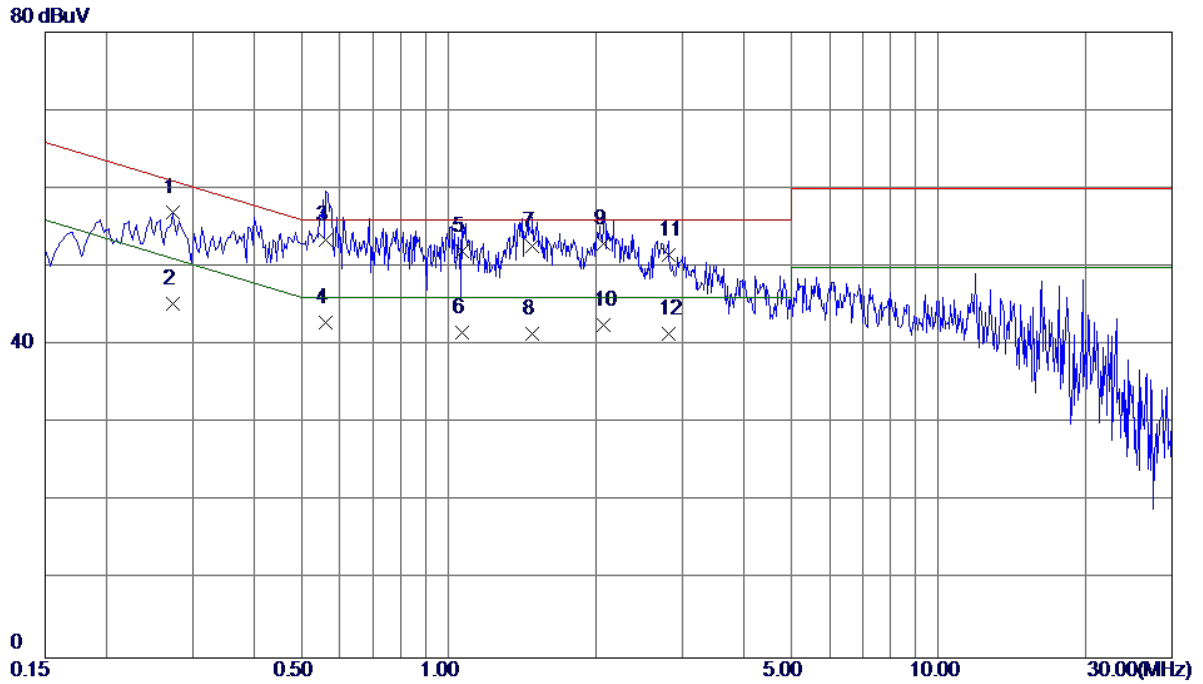

No.	Freq. MHz	Reading Level dBuV	Correct Factor dB	Measurement dBuV	Limit dBuV	Margin dB	Detector
1	0.2740	47.46	9.57	57.03	61.00	-3.97	QP
2	0.2740	35.69	9.57	45.26	51.00	-5.74	AVG
3 *	0.5620	43.90	9.50	53.40	56.00	-2.60	QP
4	0.5620	33.40	9.50	42.90	46.00	-3.10	AVG
5	1.0660	42.30	9.74	52.04	56.00	-3.96	QP
6	1.0660	31.80	9.74	41.54	46.00	-4.46	AVG
7	1.4819	42.80	9.77	52.57	56.00	-3.43	QP
8	1.4819	31.60	9.77	41.37	46.00	-4.63	AVG
9	2.0780	43.10	9.83	52.93	56.00	-3.07	QP
10	2.0780	32.80	9.83	42.63	46.00	-3.37	AVG
11	2.8060	41.60	9.95	51.55	56.00	-4.45	QP
12	2.8060	31.50	9.95	41.45	46.00	-4.55	AVG

4.2 RADIATED EMISSION MEASUREMENT

4.2.1 LIMITS OF RADIATED EMISSION MEASUREMENT

Below 1 GHz

Measurement Method and Applied Limits:

ANSI C63.4:

Frequency (MHz)	Class A (at 10m)		Class B (at 3m)	
	(uV/m) Field strength	(dBuV/m) Field strength	(uV/m) Field strength	(dBuV/m) Field strength
30 - 88	90	39	100	40
88 - 216	150	43.5	150	43.5
216 - 960	210	46.4	200	46
Above 960	300	49.5	500	54

Above 1 GHz

Measurement Method and Applied Limits:

ANSI C63.4:

Frequency (MHz)	Class A				Class B	
	(dBuV/m) (at 3m)		(dBuV/m) (at 10m)		(dBuV/m) (at 3m)	
	Peak	Average	Peak	Average	Peak	Average
Above 1000	80	60	69.5	49.5	74	54

FREQUENCY RANGE OF RADIATED MEASUREMENT (FOR UNINTENTIONAL RADIATORS)

Highest frequency generated or Upper frequency of measurement used in the device or on which the device operates or tunes (MHz)	Range (MHz)
Below 1.705	30
1.705 - 108	1000
108 - 500	2000
500 - 1000	5000
Above 1000	5 th harmonic of the highest frequency or 40 GHz, whichever is lower

NOTE:

- (1) The limit for radiated test was performed according to as following:
FCC Part 15, Subpart B
- (2) The tighter limit applies at the band edges.
- (3) Emission level (dBuV/m) = 20log Emission level (uV/m).
3m Emission level = 10m Emission level + 20log(10m/3m).
- (4) The test result calculated as following:
Measurement Value = Reading Level + Correct Factor
Correct Factor = Antenna Factor + Cable Loss - Amplifier Gain(if use)
Margin Level = Measurement Value - Limit Value

4.2.2 MEASUREMENT INSTRUMENTS LIST

Item	Kind of Equipment	Manufacturer	Type No.	Serial No.	Calibrated until
1	Log-Bicon Antenna	Schwarzbeck	VULB 9168	9168-586	Jan. 20, 2018
2	Horn Antenna	Schwarzbeck	BBHA-9120D	D 546	Nov. 03, 2017
3	Pre-Amplifier	HP	8447D	2944A08891	Mar.18, 2018
4	Pre-Amplifier	Agilent	8449B	3008A02331	Jan. 21, 2018
5	Pre-Amplifier	EMCI	EMC265404 5	980030	Feb. 13, 2018
6	Test Cable	EMCI	EMC8D-NM- NM-8000	150301	Mar.18, 2018
7	Test Cable	EMCI	EMC104-SM -SM-1000	150304	Mar.18, 2018
8	Test Cable	EMCI	EMC104-SM -SM-2500	140303	Mar.18, 2018
9	Test Cable	EMCI	EMC104-SM -SM-5000	140302	Mar.18, 2018
10	Test Cable	EMCI	EMC104-SM -SM-2500	150306	Mar.18, 2018
11	Test Cable	EMCI	EMC104-SM -SM-800	150305	Mar.18, 2018
12	EMI Test Receiver	R&S	N9038A	MY51210215	Jun. 06, 2017
13	Measurement Software	Farad	EZ EMC (Version NB-03A)	N/A	N/A

Remark: "N/A" denotes no model name, serial no. or calibration specified.
All calibration period of equipment list is one year.

4.2.3 TEST PROCEDURE

- a. The measuring distance of 3 m shall be used for measurements. The EUT was placed on the top of a rotating table 0.8 meter above the ground at a 3 meter semi-anechoic chamber. The table was rotated 360 degrees to determine the position of the highest radiation.(below 1GHz)
- b. The measuring distance of 3 m shall be used for measurements. The EUT was placed on the top of a rotating table 0.8 meter above the ground at a 3 meter semi-anechoic chamber. The table was rotated 360 degrees to determine the position of the highest radiation.(above 1GHz)
- c. The height of the equipment or of the substitution antenna shall be 0.8 m, the height of the test antenna shall vary between 1 m to 4 m. Both horizontal and vertical polarizations of the antenna are set to make the measurement.
- d. For each suspected emission, the EUT was arranged to its worst case and then the antenna was tuned to heights find the maximum reading (used Bore sight function).
- e. The receiver system was set to peak and average detect function and specified bandwidth with maximum hold mode when the test frequency is above 1GHz.
- f. The initial step in collecting radiated emission data is a receiver peak detector mode pre-scanning the measurement frequency range. Significant peaks are then marked and then Quasi Peak detector mode re-measured.
- g. All readings are Peak unless otherwise stated QP in column of Note. Peak denotes that the Peak reading compliance with the QP Limits and then QP Mode measurement didn't perform. (below 1GHz)
- h. All readings are Peak Mode value unless otherwise stated AVG in column of Note. If the Peak Mode Measured value compliance with the Peak Limits and lower than AVG Limits, the EUT shall be deemed to meet both Peak & AVG Limits and then only Peak Mode was measured, but AVG Mode didn't perform. (above 1GHz)
- i. For the actual test configuration, please refer to the related Item - Block Diagram of system tested (please refer to 3.3).

4.2.4 DEVIATION FROM TEST STANDARD

No deviation

4.2.5 TEST SETUP

(A) Radiated Emission Test Set-Up Frequency Below 1 GHz

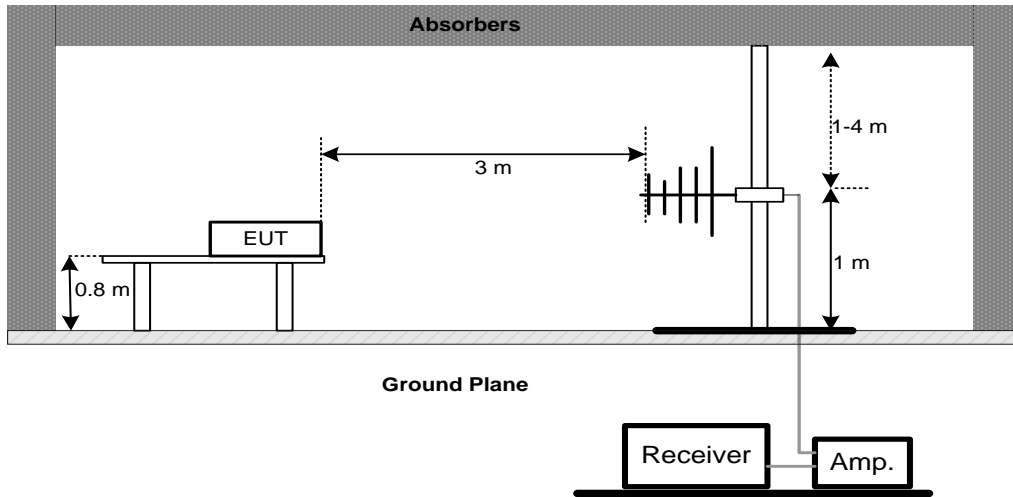

(B) Radiated Emission Test Set-Up Frequency 1 GHz

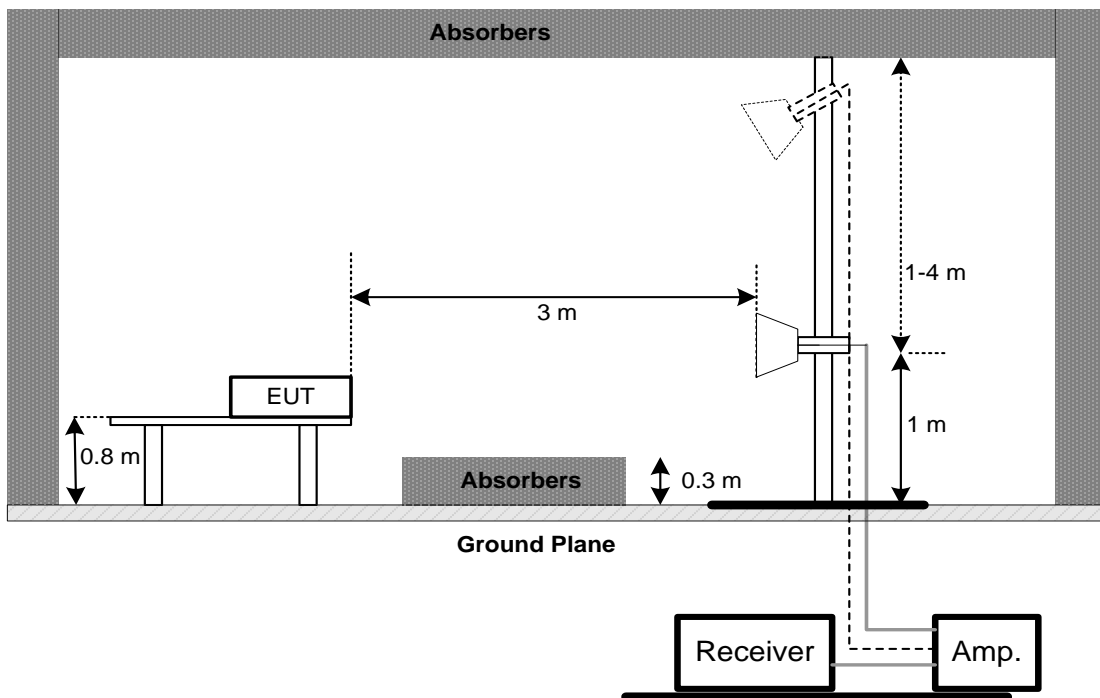

4.2.6 TEST RESULTS-BELOW 1GHZ

Remark :

- (1) All readings are Peak unless otherwise stated QP in column of 『Note』 . Peak denotes that the Peak reading compliance with the QP Limits and then QP Mode measurement didn't perform ◦
- (2) Measuring frequency range from 30MHz to 1000MHz ◦
- (3) If the peak scan value lower limit more than 20dB, then this signal data does not show in table ◦

EUT	IP Phone	Model Name	X4
Temperature	25°C	Relative Humidity	60%
Test Voltage	AC 120V/60Hz	Polarization	Vertical
Test Mode	Handfree		
Note	Adapter		
Test Engineer	Pike Lee		

80 dBuV/m

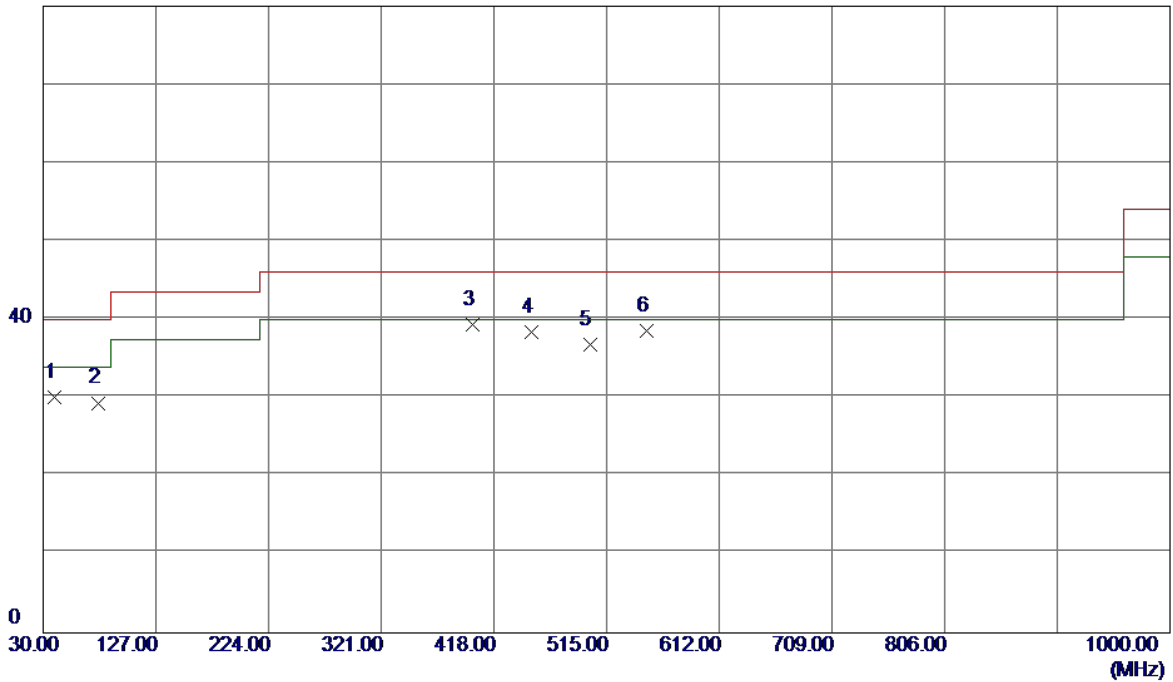

No.	Freq. MHz	Reading Level dBuV/m	Correct Factor dB	Measure ment dBuV/m	Limit dBuV/m	Margin dB	Detector
1	39.7000	42.83	-12.71	30.12	40.00	-9.88	QP
2	77.5300	45.56	-16.20	29.36	40.00	-10.64	QP
3 *	399.5700	47.63	-8.22	39.41	46.00	-6.59	QP
4	450.0100	45.44	-6.98	38.46	46.00	-7.54	QP
5	500.4500	42.58	-5.84	36.74	46.00	-9.26	QP
6	549.9200	43.15	-4.55	38.60	46.00	-7.40	QP

EUT	IP Phone	Model Name	X4
Temperature	25°C	Relative Humidity	60%
Test Voltage	AC 120V/60Hz	Polarization	Horizontal
Test Mode	Handfree		
Note	Adapter		
Test Engineer	Pike Lee		

80 dBuV/m

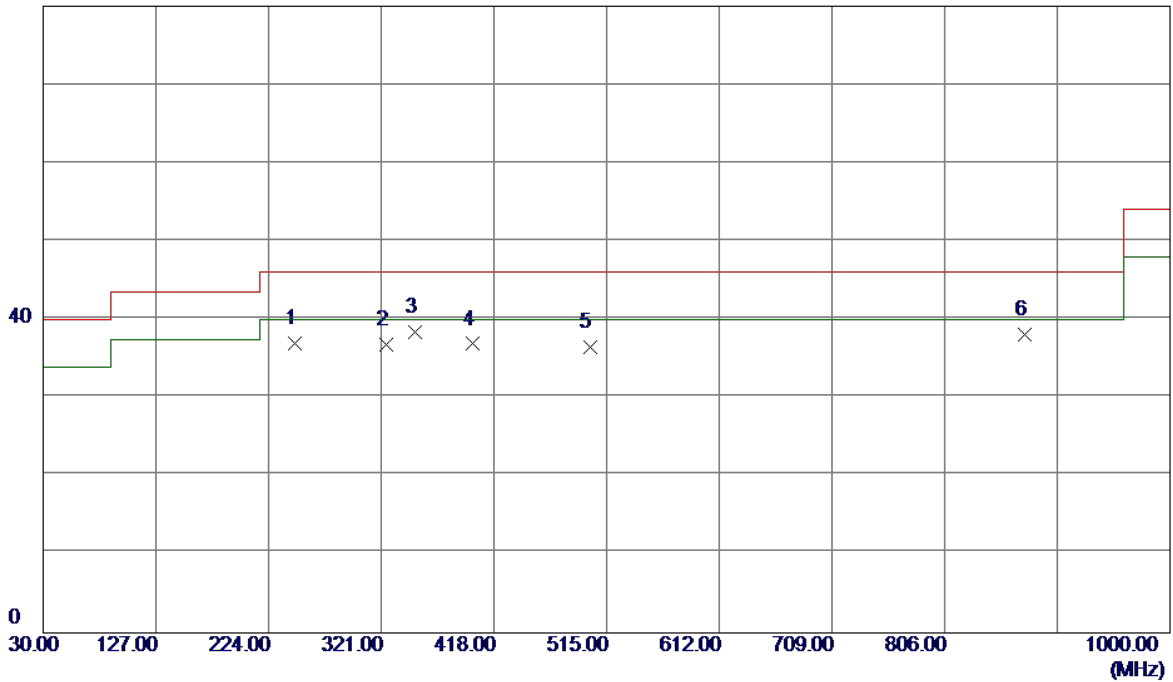

No.	Freq. MHz	Reading Level dBuV/m	Correct Factor dB	Measure ment dBuV/m	Limit dBuV/m	Margin dB	Detector
1	246.3100	50.26	-13.29	36.97	46.00	-9.03	QP
2	324.8800	46.82	-10.07	36.75	46.00	-9.25	QP
3 *	350.1000	47.86	-9.48	38.38	46.00	-7.62	QP
4	399.5700	45.10	-8.22	36.88	46.00	-9.12	QP
5	500.4500	42.32	-5.84	36.48	46.00	-9.52	QP
6	874.8700	35.69	2.40	38.09	46.00	-7.91	QP

EUT	IP Phone	Model Name	X4
Temperature	25°C	Relative Humidity	60%
Test Voltage	DC 48V	Polarization	Vertical
Test Mode	Handfree		
Note	PoE		
Test Engineer	Pike Lee		

80 dBuV/m

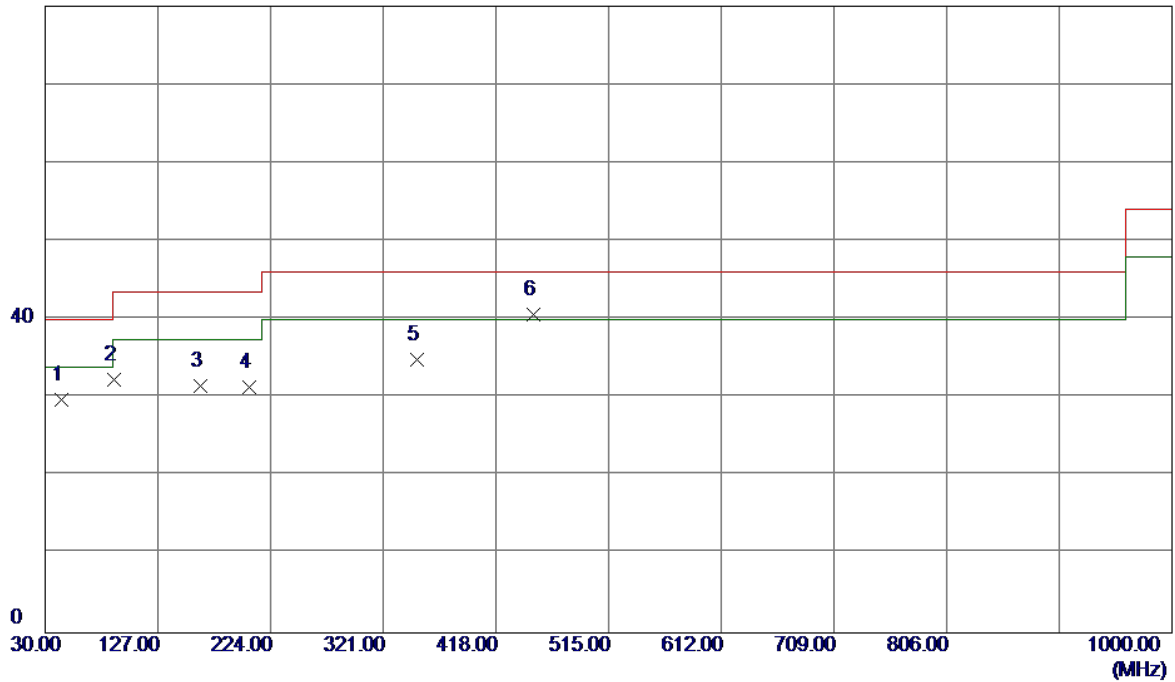

No.	Freq. MHz	Reading Level dBuV/m	Correct Factor dB	Measure ment dBuV/m	Limit dBuV/m	Margin dB	Detector
1	43.5800	41.81	-12.07	29.74	40.00	-10.26	QP
2	89.1700	49.60	-17.22	32.38	43.50	-11.12	QP
3	163.8600	42.92	-11.36	31.56	43.50	-11.94	QP
4	205.5700	44.10	-12.67	31.43	43.50	-12.07	QP
5	350.1000	44.36	-9.48	34.88	46.00	-11.12	QP
6 *	450.0100	47.57	-6.98	40.59	46.00	-5.41	QP

EUT	IP Phone	Model Name	X4
Temperature	25°C	Relative Humidity	60%
Test Voltage	DC 48V	Polarization	Horizontal
Test Mode	Handfree		
Note	PoE		
Test Engineer	Pike Lee		

80 dBuV/m

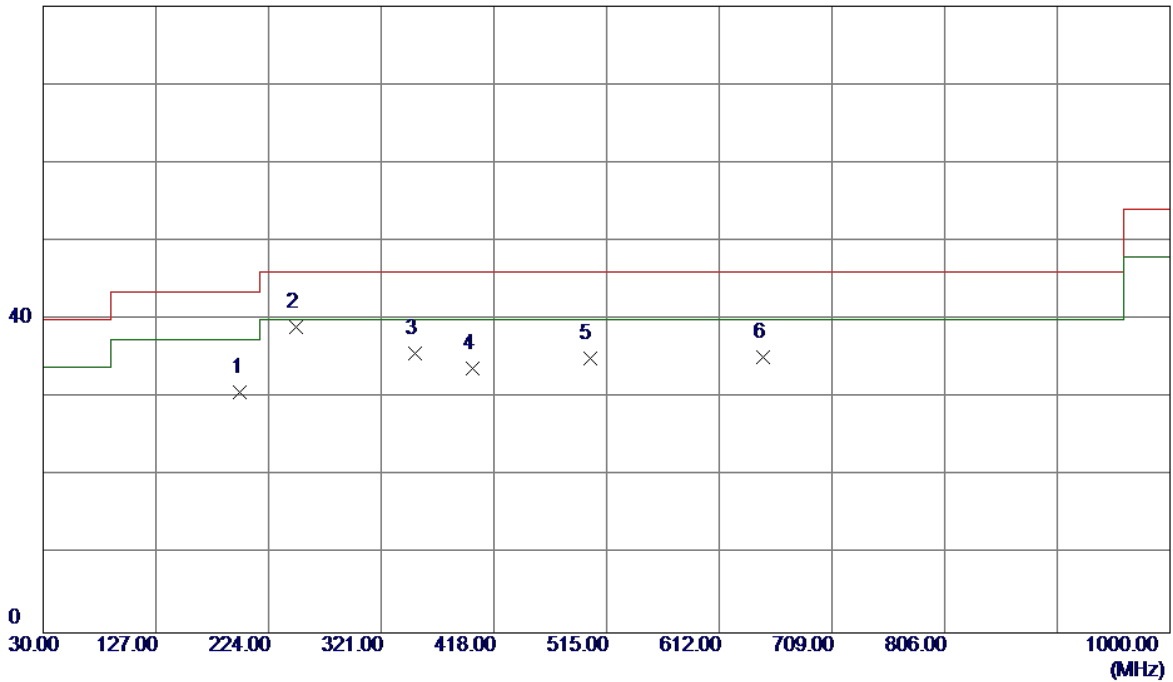

No.	Freq. MHz	Reading Level dBuV/m	Correct Factor dB	Measure ment dBuV/m	Limit dBuV/m	Margin dB	Detector
1	199.7500	42.84	-12.11	30.73	43.50	-12.77	QP
2 *	247.2800	52.35	-13.28	39.07	46.00	-6.93	QP
3	350.1000	45.17	-9.48	35.69	46.00	-10.31	QP
4	399.5700	42.04	-8.22	33.82	46.00	-12.18	QP
5	500.4500	40.95	-5.84	35.11	46.00	-10.89	QP
6	649.8300	37.44	-2.31	35.13	46.00	-10.87	QP

EUT	IP Phone	Model Name	X4
Temperature	25°C	Relative Humidity	60%
Test Voltage	AC 120V/60Hz	Polarization	Vertical
Test Mode	Handset		
Note	Adapter		
Test Engineer	Pike Lee		

80 dBuV/m

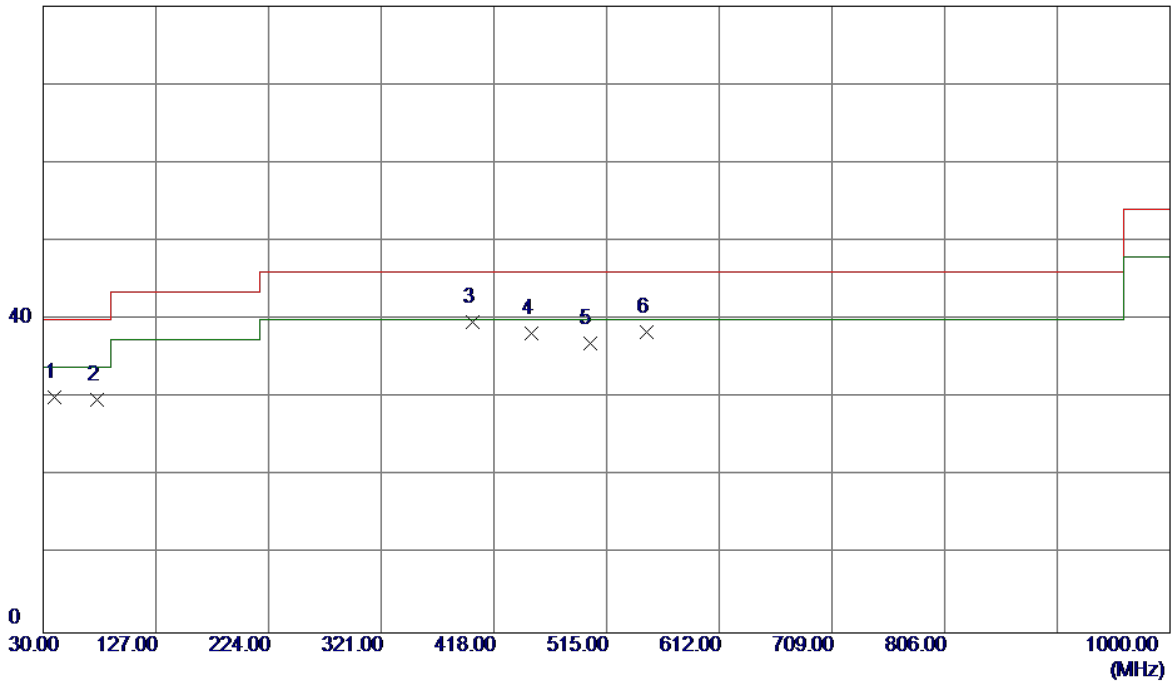

No.	Freq. MHz	Reading Level dBuV/m	Correct Factor dB	Measure ment dBuV/m	Limit dBuV/m	Margin dB	Detector
1	39.7000	42.85	-12.71	30.14	40.00	-9.86	QP
2	76.5600	45.71	-15.99	29.72	40.00	-10.28	QP
3 *	399.5700	47.97	-8.22	39.75	46.00	-6.25	QP
4	450.0100	45.20	-6.98	38.22	46.00	-7.78	QP
5	500.4500	42.78	-5.84	36.94	46.00	-9.06	QP
6	549.9200	43.01	-4.55	38.46	46.00	-7.54	QP

EUT	IP Phone	Model Name	X4
Temperature	25°C	Relative Humidity	60%
Test Voltage	AC 120V/60Hz	Polarization	Horizontal
Test Mode	Handset		
Note	Adapter		
Test Engineer	Pike Lee		

80 dBuV/m

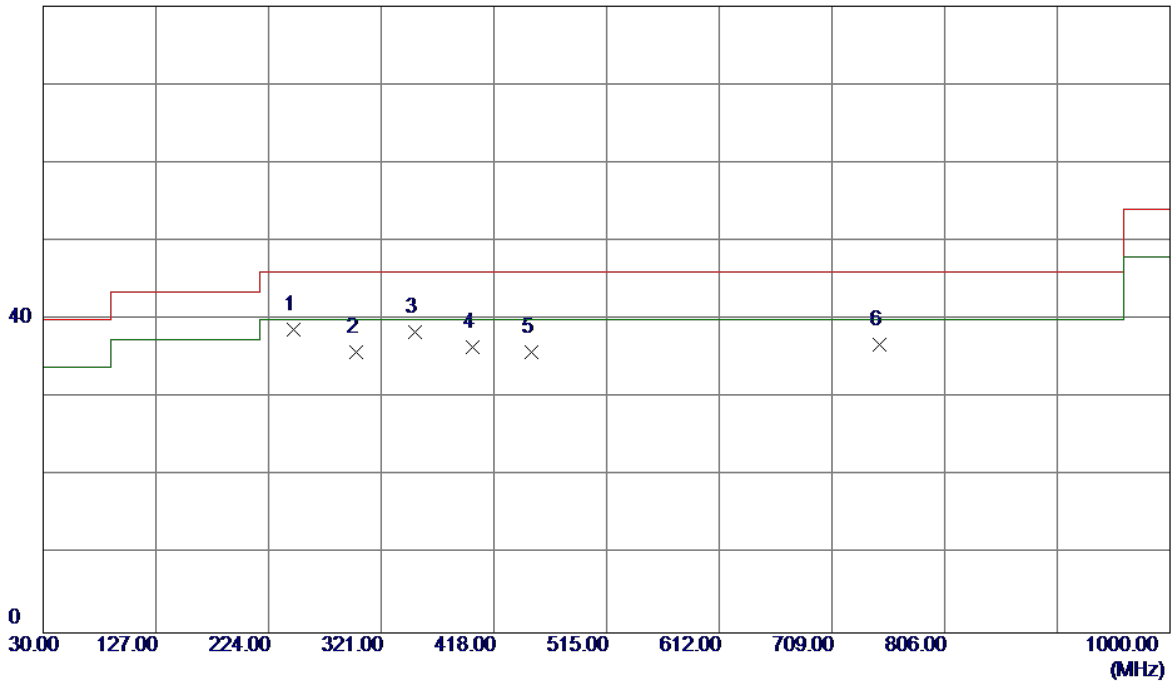

No.	Freq. MHz	Reading Level dBuV/m	Correct Factor dB	Measure ment dBuV/m	Limit dBuV/m	Margin dB	Detector
1 *	245.3400	52.03	-13.30	38.73	46.00	-7.27	QP
2	299.6600	46.53	-10.69	35.84	46.00	-10.16	QP
3	350.1000	47.91	-9.48	38.43	46.00	-7.57	QP
4	399.5700	44.70	-8.22	36.48	46.00	-9.52	QP
5	450.0100	42.83	-6.98	35.85	46.00	-10.15	QP
6	749.7400	36.90	-0.14	36.76	46.00	-9.24	QP

EUT	IP Phone	Model Name	X4
Temperature	25°C	Relative Humidity	60%
Test Voltage	DC 48V	Polarization	Vertical
Test Mode	Handset		
Note	PoE		
Test Engineer	Pike Lee		

80 dBuV/m

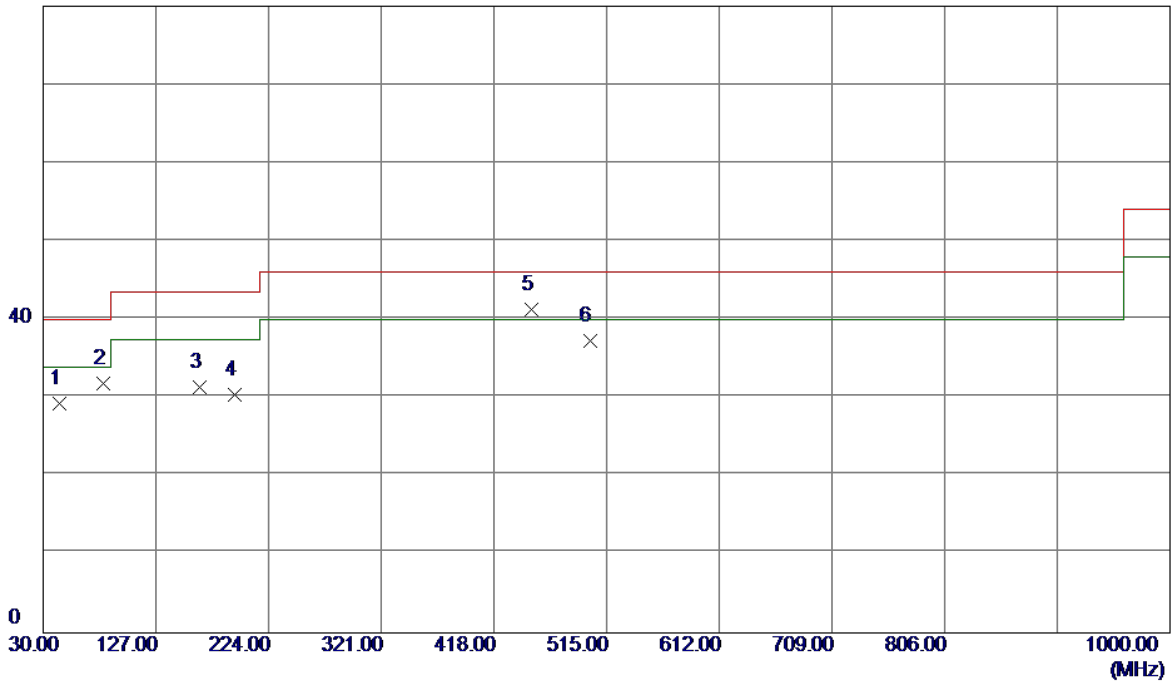

No.	Freq. MHz	Reading Level dBuV/m	Correct Factor dB	Measure ment dBuV/m	Limit dBuV/m	Margin dB	Detector
1	43.5800	41.35	-12.07	29.28	40.00	-10.72	QP
2	81.4100	48.62	-16.80	31.82	40.00	-8.18	QP
3	164.8300	42.69	-11.32	31.37	43.50	-12.13	QP
4	194.9000	42.14	-11.80	30.34	43.50	-13.16	QP
5 *	450.0100	48.24	-6.98	41.26	46.00	-4.74	QP
6	500.4500	43.18	-5.84	37.34	46.00	-8.66	QP

EUT	IP Phone	Model Name	X4
Temperature	25°C	Relative Humidity	60%
Test Voltage	DC 48V	Polarization	Horizontal
Test Mode	Handset		
Note	PoE		
Test Engineer	Pike Lee		

80 dBuV/m

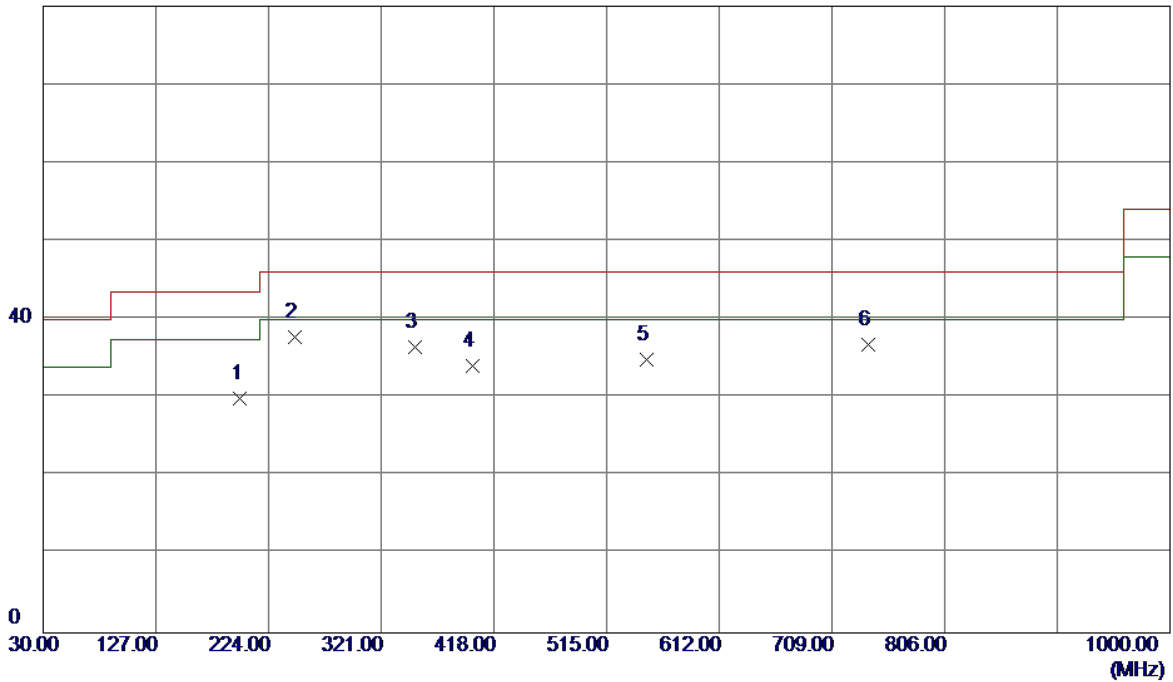

No.	Freq. MHz	Reading Level dBuV/m	Correct Factor dB	Measure ment dBuV/m	Limit dBuV/m	Margin dB	Detector
1	199.7500	42.00	-12.11	29.89	43.50	-13.61	QP
2 *	246.3100	51.10	-13.29	37.81	46.00	-8.19	QP
3	350.1000	45.95	-9.48	36.47	46.00	-9.53	QP
4	399.5700	42.25	-8.22	34.03	46.00	-11.97	QP
5	549.9200	39.38	-4.55	34.83	46.00	-11.17	QP
6	740.0400	37.07	-0.33	36.74	46.00	-9.26	QP

EUT	IP Phone	Model Name	X4
Temperature	25°C	Relative Humidity	60%
Test Voltage	AC 120V/60Hz	Polarization	Vertical
Test Mode	Earphone		
Note	Adapter		
Test Engineer	Pike Lee		

80 dBuV/m

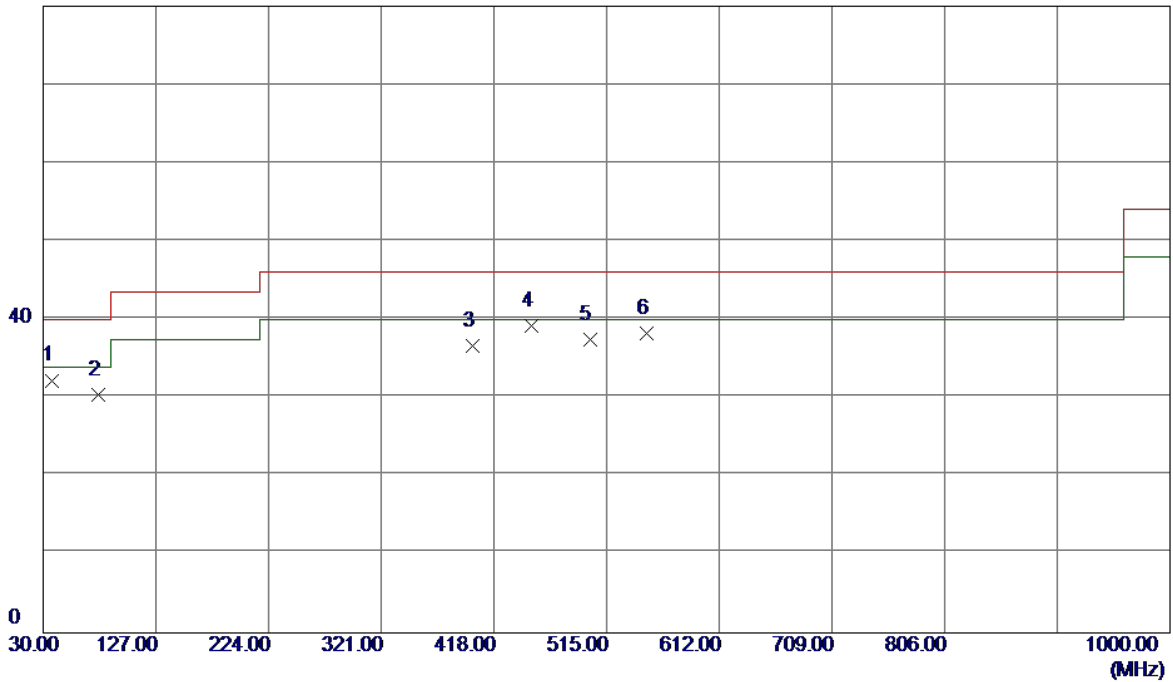

No.	Freq. MHz	Reading Level dBuV/m	Correct Factor dB	Measure ment dBuV/m	Limit dBuV/m	Margin dB	Detector
1	37.7599	45.08	-12.84	32.24	40.00	-7.76	QP
2	77.5300	46.63	-16.20	30.43	40.00	-9.57	QP
3	399.5700	44.90	-8.22	36.68	46.00	-9.32	QP
4 *	450.0100	46.22	-6.98	39.24	46.00	-6.76	QP
5	500.4500	43.30	-5.84	37.46	46.00	-8.54	QP
6	549.9200	42.85	-4.55	38.30	46.00	-7.70	QP

EUT	IP Phone	Model Name	X4
Temperature	25°C	Relative Humidity	60%
Test Voltage	AC 120V/60Hz	Polarization	Horizontal
Test Mode	Earphone		
Note	Adapter		
Test Engineer	Pike Lee		

80 dBuV/m

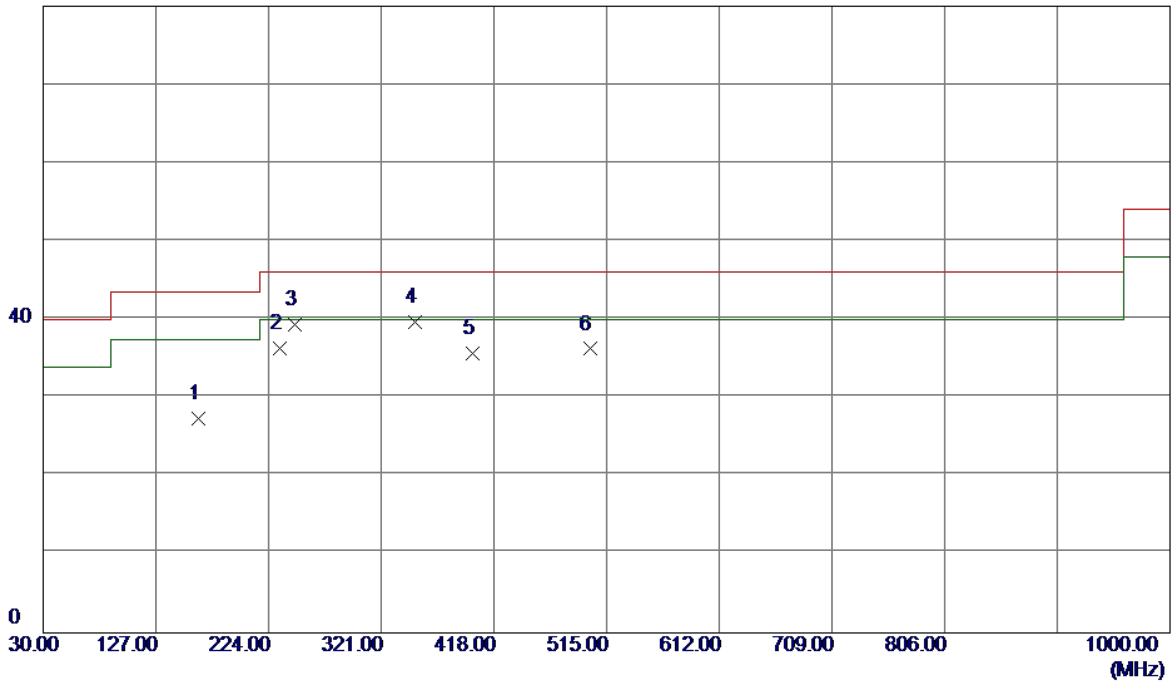

No.	Freq. MHz	Reading Level dBuV/m	Correct Factor dB	Measure ment dBuV/m	Limit dBuV/m	Margin dB	Detector
1	163.8600	38.67	-11.36	27.31	43.50	-16.19	QP
2	233.7000	49.59	-13.28	36.31	46.00	-9.69	QP
3	246.3100	52.68	-13.29	39.39	46.00	-6.61	QP
4 *	350.1000	49.11	-9.48	39.63	46.00	-6.37	QP
5	399.5700	43.93	-8.22	35.71	46.00	-10.29	QP
6	500.4500	42.08	-5.84	36.24	46.00	-9.76	QP

EUT	IP Phone	Model Name	X4
Temperature	25°C	Relative Humidity	60%
Test Voltage	DC 48V	Polarization	Vertical
Test Mode	Earphone		
Note	PoE		
Test Engineer	Pike Lee		

80 dBuV/m

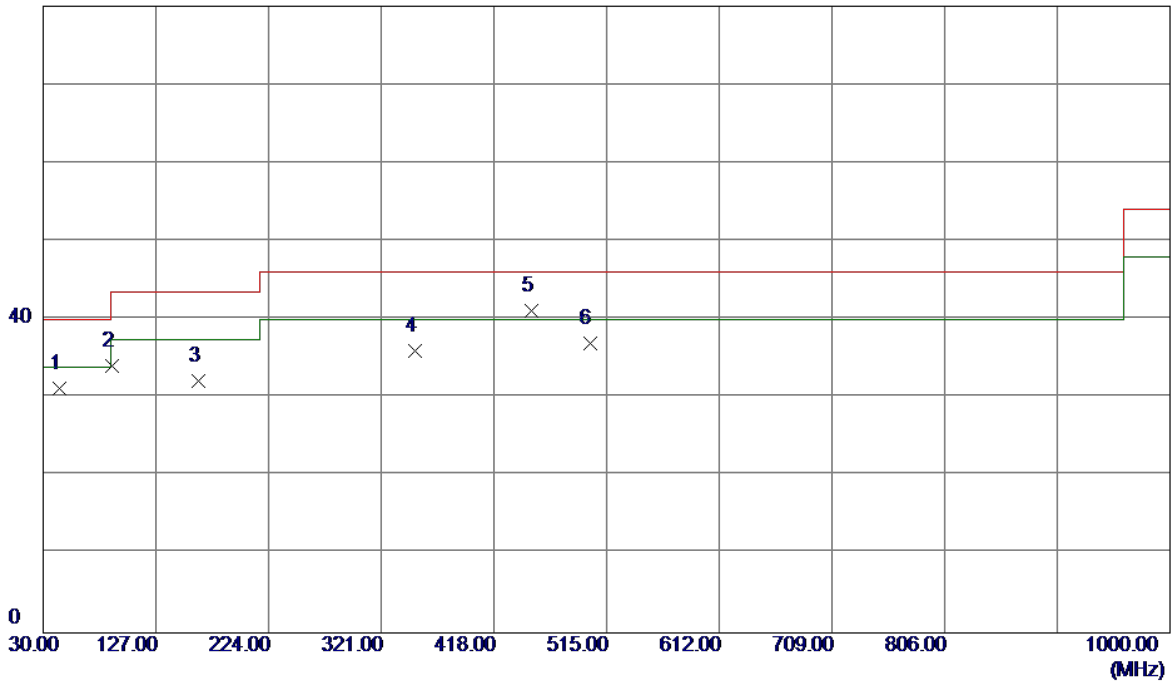

No.	Freq. MHz	Reading Level dBuV/m	Correct Factor dB	Measure ment dBuV/m	Limit dBuV/m	Margin dB	Detector
1	43.5800	43.28	-12.07	31.21	40.00	-8.79	QP
2	89.1700	51.28	-17.22	34.06	43.50	-9.44	QP
3	163.8600	43.55	-11.36	32.19	43.50	-11.31	QP
4	350.1000	45.51	-9.48	36.03	46.00	-9.97	QP
5 *	450.0100	48.03	-6.98	41.05	46.00	-4.95	QP
6	500.4500	42.82	-5.84	36.98	46.00	-9.02	QP

EUT	IP Phone	Model Name	X4
Temperature	25°C	Relative Humidity	60%
Test Voltage	DC 48V	Polarization	Horizontal
Test Mode	Earphone		
Note	PoE		
Test Engineer	Pike Lee		

80 dBuV/m

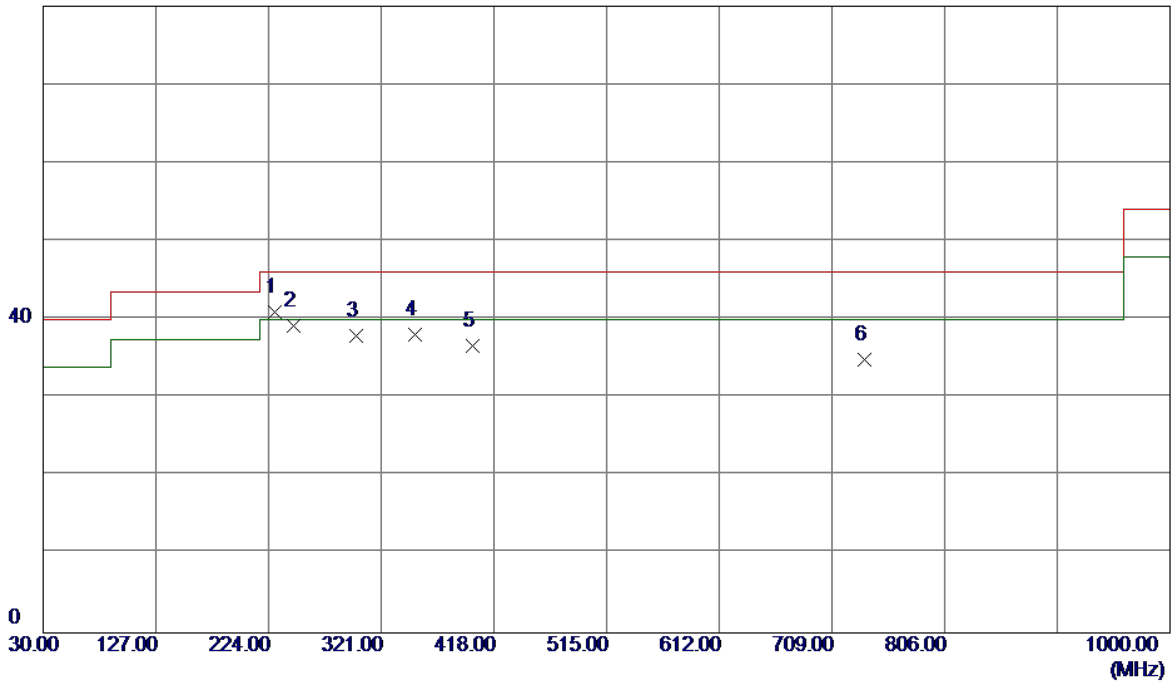

No.	Freq. MHz	Reading Level dBuV/m	Correct Factor dB	Measure ment dBuV/m	Limit dBuV/m	Margin dB	Detector
1 *	229.8200	54.20	-13.22	40.98	46.00	-5.02	QP
2	245.3400	52.54	-13.30	39.24	46.00	-6.76	QP
3	299.6600	48.63	-10.69	37.94	46.00	-8.06	QP
4	350.1000	47.57	-9.48	38.09	46.00	-7.91	QP
5	399.5700	44.83	-8.22	36.61	46.00	-9.39	QP
6	737.1300	35.28	-0.38	34.90	46.00	-11.10	QP

4.2.7 TEST RESULTS-ABOVE 1GHZ

Remark :

- (1) All readings are Peak unless otherwise stated QP in column of『Note』. Peak denotes that the Peak reading compliance with the QP Limits and then QP Mode measurement didn't perform.
- (2) Radiated emissions measured in frequency range above 1000MHz were made with an instrument using Peak detector mode and AV detector mode of the emission.
- (3) Data of measurement within this frequency range shown “ * ” in the table above means the reading of emissions are attenuated more than 20dB below the permissible limits or the field strength is too small to be measured.
- (4) A preamp and high pass filter were used for this test in order to provide sufficient measurement sensitivity.

EUT	IP Phone	Model Name	X4
Temperature	25°C	Relative Humidity	60%
Test Voltage	DC 48V	Polarization	Vertical
Test Mode	Handfree		
Note	PoE		
Test Engineer	Pike Lee		

80 dBuV/m

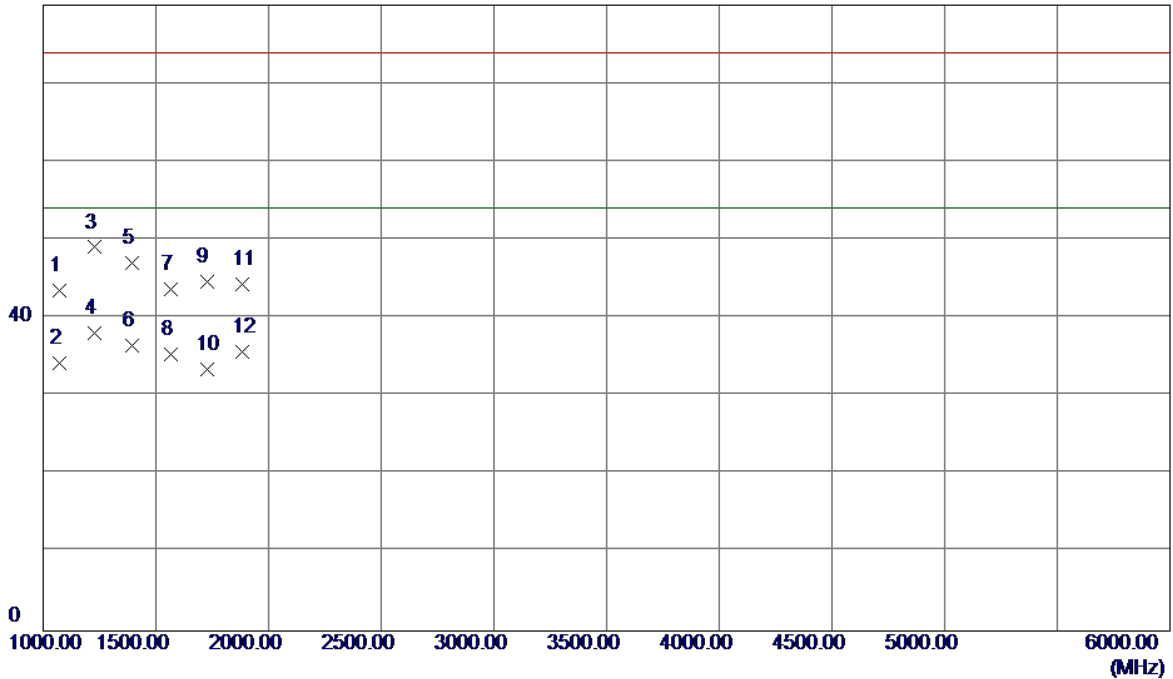

No.	Freq. MHz	Reading Level dBuV/m	Correct Factor dB	Measure ment dBuV/m	Limit dBuV/m	Margin dB	Detector
1	1070.0000	48.92	-5.33	43.59	74.00	-30.41	Peak
2	1070.0000	39.62	-5.33	34.29	54.00	-19.71	AVG
3	1230.0000	53.72	-4.68	49.04	74.00	-24.96	Peak
4 *	1230.0000	42.75	-4.68	38.07	54.00	-15.93	AVG
5	1395.0000	50.98	-4.01	46.97	74.00	-27.03	Peak
6	1395.0000	40.52	-4.01	36.51	54.00	-17.49	AVG
7	1565.0000	47.03	-3.35	43.68	74.00	-30.32	Peak
8	1565.0000	38.72	-3.35	35.37	54.00	-18.63	AVG
9	1725.0000	47.43	-2.76	44.67	74.00	-29.33	Peak
10	1725.0000	36.26	-2.76	33.50	54.00	-20.50	AVG
11	1885.0000	46.52	-2.18	44.34	74.00	-29.66	Peak
12	1885.0000	37.85	-2.18	35.67	54.00	-18.33	AVG

EUT	IP Phone	Model Name	X4
Temperature	25°C	Relative Humidity	60%
Test Voltage	DC 48V	Polarization	Horizontal
Test Mode	Handfree		
Note	PoE		
Test Engineer	Pike Lee		

80 dBuV/m

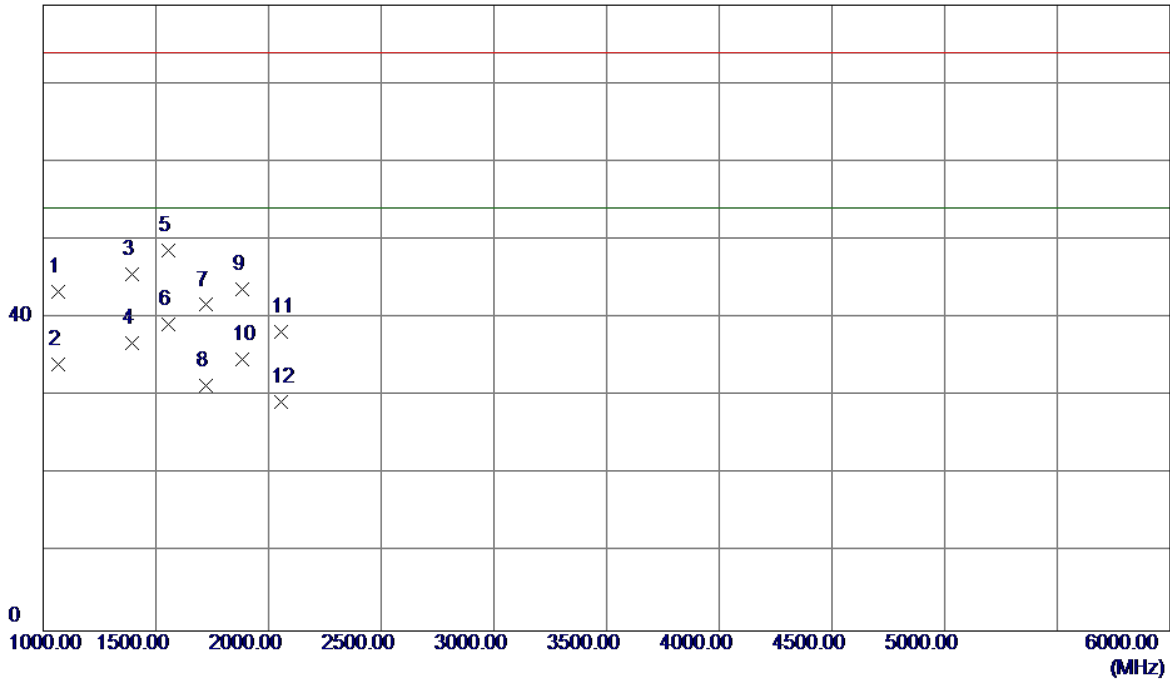

No.	Freq. MHz	Reading Level dBuV/m	Correct Factor dB	Measure ment dBuV/m	Limit dBuV/m	Margin dB	Detector
1	1065.0000	48.72	-5.35	43.37	74.00	-30.63	Peak
2	1065.0000	39.43	-5.35	34.08	54.00	-19.92	AVG
3	1395.0000	49.64	-4.01	45.63	74.00	-28.37	Peak
4	1395.0000	40.82	-4.01	36.81	54.00	-17.19	AVG
5	1555.0000	51.98	-3.38	48.60	74.00	-25.40	Peak
6 *	1555.0000	42.65	-3.38	39.27	54.00	-14.73	AVG
7	1720.0000	44.46	-2.78	41.68	74.00	-32.32	Peak
8	1720.0000	34.17	-2.78	31.39	54.00	-22.61	AVG
9	1885.0000	45.88	-2.18	43.70	74.00	-30.30	Peak
10	1885.0000	36.96	-2.18	34.78	54.00	-19.22	AVG
11	2055.0000	39.68	-1.47	38.21	74.00	-35.79	Peak
12	2055.0000	30.74	-1.47	29.27	54.00	-24.73	AVG

EUT	IP Phone	Model Name	X4
Temperature	25°C	Relative Humidity	60%
Test Voltage	AC 120V/60Hz	Polarization	Vertical
Test Mode	Handfree		
Note	Adapter		
Test Engineer	Pike Lee		

100 dBuV/m

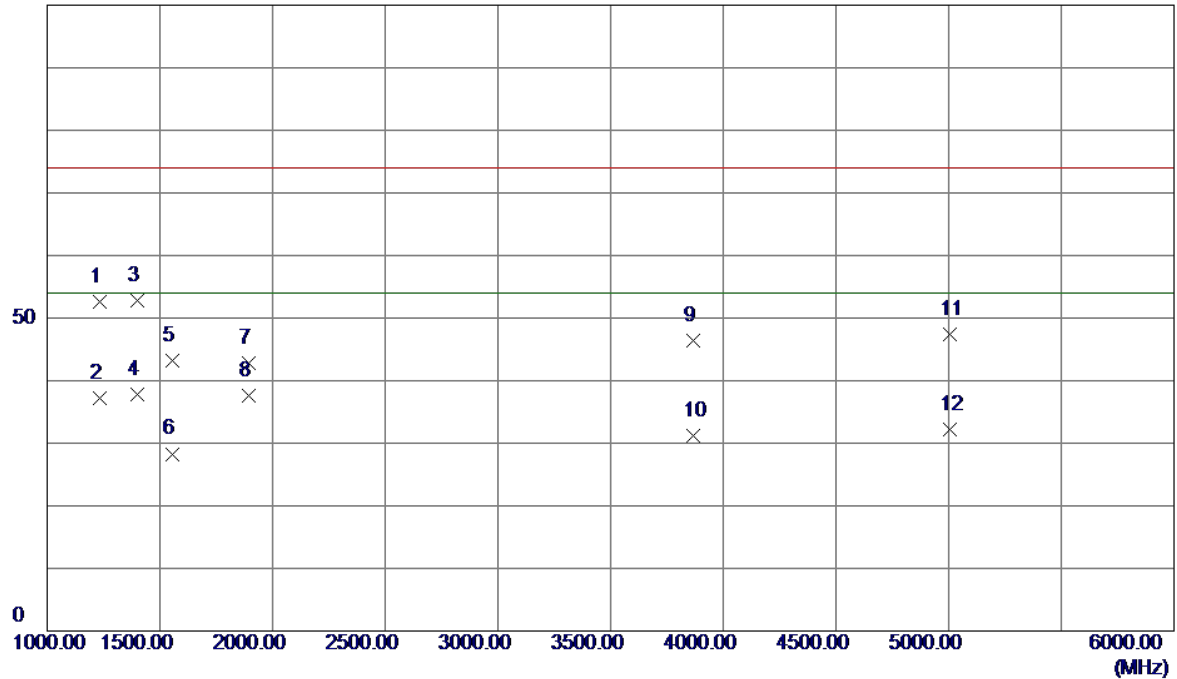

No.	Freq. MHz	Reading Level dBuV/m	Correct Factor dB	Measure ment dBuV/m	Limit dBuV/m	Margin dB	Detector
1	1232.5000	56.63	-4.08	52.55	74.00	-21.45	Peak
2	1232.5000	41.23	-4.08	37.15	54.00	-16.85	AVG
3	1400.0000	56.33	-3.53	52.80	74.00	-21.20	Peak
4 *	1400.0000	41.37	-3.53	37.84	54.00	-16.16	AVG
5	1557.5000	46.51	-3.22	43.29	74.00	-30.71	Peak
6	1557.5000	31.52	-3.22	28.30	54.00	-25.70	AVG
7	1892.5000	46.24	-3.35	42.89	74.00	-31.11	Peak
8	1892.5000	40.89	-3.35	37.54	54.00	-16.46	AVG
9	3865.0000	41.58	4.82	46.40	74.00	-27.60	Peak
10	3865.0000	26.37	4.82	31.19	54.00	-22.81	AVG
11	5005.0000	41.11	6.30	47.41	74.00	-26.59	Peak
12	5005.0000	25.88	6.30	32.18	54.00	-21.82	AVG

EUT	IP Phone	Model Name	X4
Temperature	25°C	Relative Humidity	60%
Test Voltage	AC 120V/60Hz	Polarization	Horizontal
Test Mode	Handfree		
Note	Adapter		
Test Engineer	Pike Lee		

100 dBuV/m

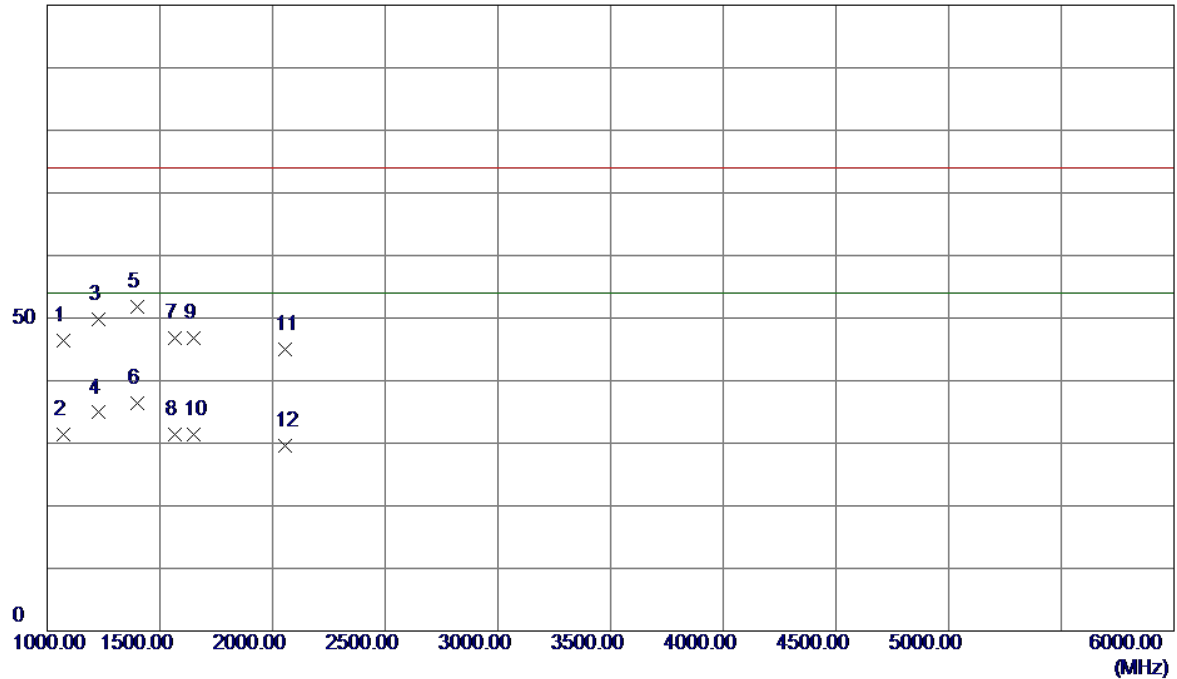

No.	Freq. MHz	Reading Level dBuV/m	Correct Factor dB	Measure ment dBuV/m	Limit dBuV/m	Margin dB	Detector
1	1072.5000	50.98	-4.61	46.37	74.00	-27.63	Peak
2	1072.5000	36.09	-4.61	31.48	54.00	-22.52	AVG
3	1230.0000	53.97	-4.09	49.88	74.00	-24.12	Peak
4	1230.0000	38.99	-4.09	34.90	54.00	-19.10	AVG
5	1400.0000	55.42	-3.53	51.89	74.00	-22.11	Peak
6 *	1400.0000	39.84	-3.53	36.31	54.00	-17.69	AVG
7	1567.5000	50.06	-3.23	46.83	74.00	-27.17	Peak
8	1567.5000	34.65	-3.23	31.42	54.00	-22.58	AVG
9	1650.0000	50.01	-3.26	46.75	74.00	-27.25	Peak
10	1650.0000	34.68	-3.26	31.42	54.00	-22.58	AVG
11	2057.5000	47.90	-2.97	44.93	74.00	-29.07	Peak
12	2057.5000	32.64	-2.97	29.67	54.00	-24.33	AVG

EUT	IP Phone	Model Name	X4
Temperature	25°C	Relative Humidity	60%
Test Voltage	DC 48V	Polarization	Vertical
Test Mode	Handset		
Note	PoE		
Test Engineer	Pike Lee		

80 dBuV/m

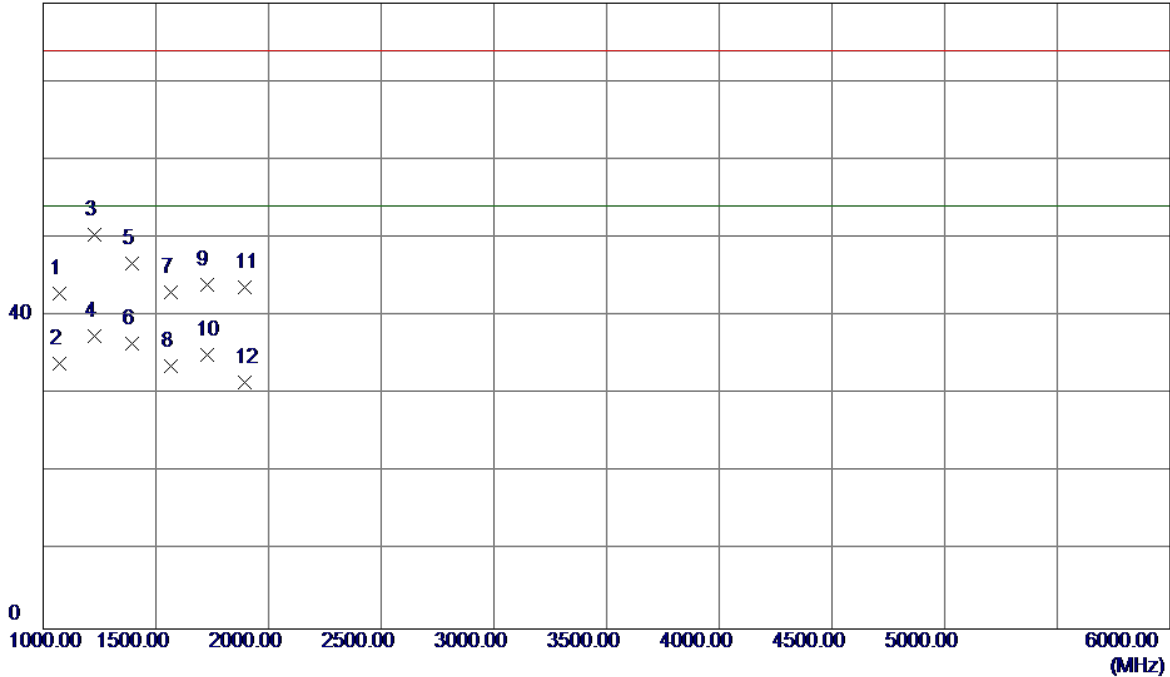

No.	Freq. MHz	Reading Level dBuV/m	Correct Factor dB	Measurement dBuV/m	Limit dBuV/m	Margin dB	Detector
1	1070.0000	48.23	-5.33	42.90	74.00	-31.10	Peak
2	1070.0000	39.24	-5.33	33.91	54.00	-20.09	AVG
3	1230.0000	55.03	-4.68	50.35	74.00	-23.65	Peak
4 *	1230.0000	42.17	-4.68	37.49	54.00	-16.51	AVG
5	1395.0000	50.77	-4.01	46.76	74.00	-27.24	Peak
6	1395.0000	40.51	-4.01	36.50	54.00	-17.50	AVG
7	1565.0000	46.39	-3.35	43.04	74.00	-30.96	Peak
8	1565.0000	36.92	-3.35	33.57	54.00	-20.43	AVG
9	1725.0000	46.83	-2.76	44.07	74.00	-29.93	Peak
10	1725.0000	37.85	-2.76	35.09	54.00	-18.91	AVG
11	1895.0000	45.83	-2.14	43.69	74.00	-30.31	Peak
12	1895.0000	33.60	-2.14	31.46	54.00	-22.54	AVG

EUT	IP Phone	Model Name	X4
Temperature	25°C	Relative Humidity	60%
Test Voltage	DC 48V	Polarization	Horizontal
Test Mode	Handset		
Note	PoE		
Test Engineer	Pike Lee		

80 dBuV/m

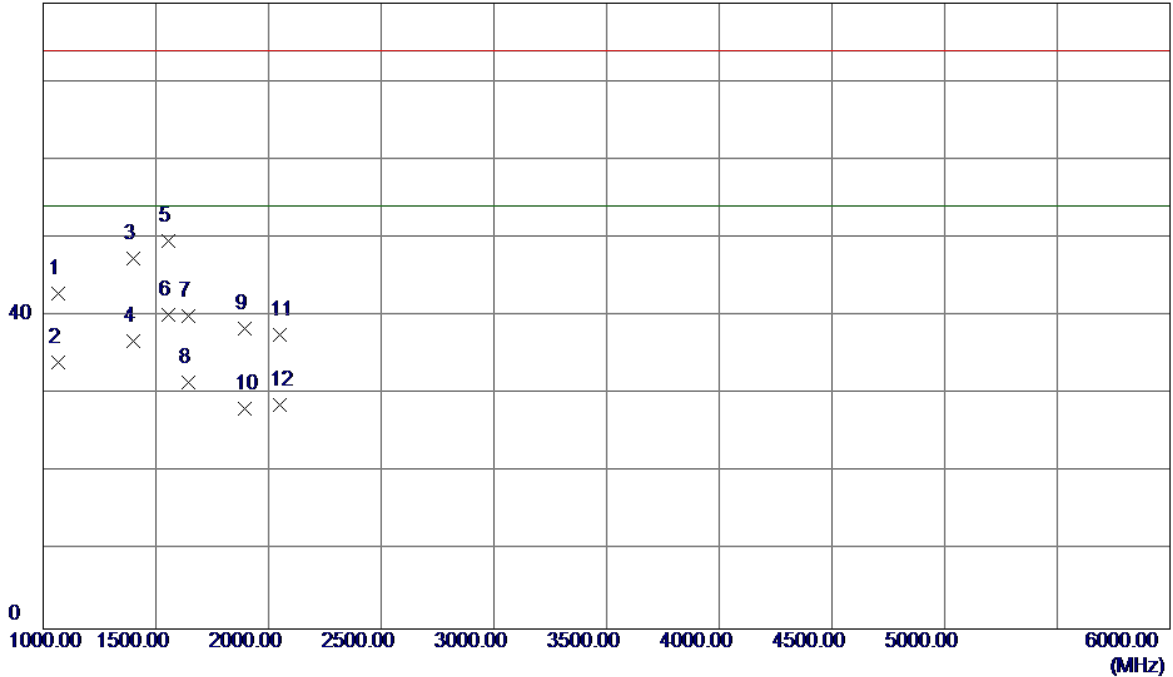

No.	Freq. MHz	Reading Level dBuV/m	Correct Factor dB	Measurement dBuV/m	Limit dBuV/m	Margin dB	Detector
1	1065.0000	48.21	-5.35	42.86	74.00	-31.14	Peak
2	1065.0000	39.46	-5.35	34.11	54.00	-19.89	AVG
3	1400.0000	51.33	-3.99	47.34	74.00	-26.66	Peak
4	1400.0000	40.83	-3.99	36.84	54.00	-17.16	AVG
5	1555.0000	52.96	-3.38	49.58	74.00	-24.42	Peak
6 *	1555.0000	43.57	-3.38	40.19	54.00	-13.81	AVG
7	1645.0000	43.12	-3.06	40.06	74.00	-33.94	Peak
8	1645.0000	34.56	-3.06	31.50	54.00	-22.50	AVG
9	1895.0000	40.50	-2.14	38.36	74.00	-35.64	Peak
10	1895.0000	30.33	-2.14	28.19	54.00	-25.81	AVG
11	2050.0000	39.14	-1.50	37.64	74.00	-36.36	Peak
12	2050.0000	30.19	-1.50	28.69	54.00	-25.31	AVG

EUT	IP Phone	Model Name	X4
Temperature	25°C	Relative Humidity	60%
Test Voltage	AC 120V/60Hz	Polarization	Vertical
Test Mode	Handset		
Note	Adapter		
Test Engineer	Pike Lee		

100 dBuV/m

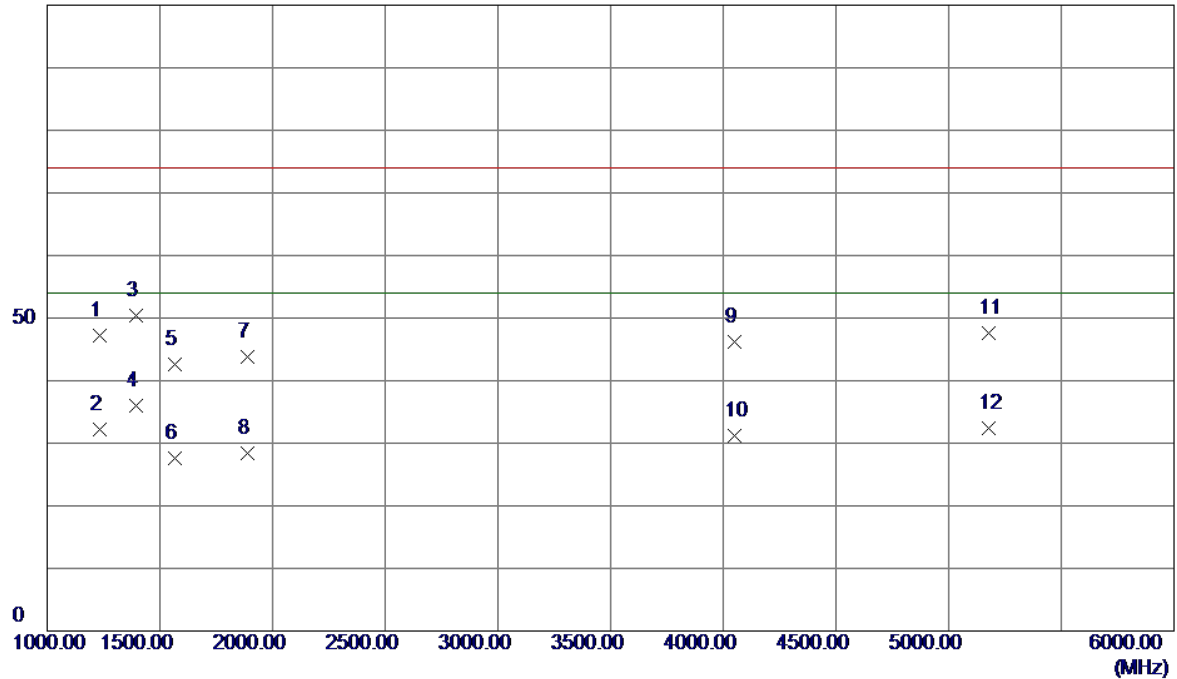

No.	Freq. MHz	Reading Level dBuV/m	Correct Factor dB	Measure ment dBuV/m	Limit dBuV/m	Margin dB	Detector
1	1232.5000	51.35	-4.08	47.27	74.00	-26.73	Peak
2	1232.5000	36.24	-4.08	32.16	54.00	-21.84	AVG
3	1395.0000	53.92	-3.55	50.37	74.00	-23.63	Peak
4 *	1395.0000	39.52	-3.55	35.97	54.00	-18.03	AVG
5	1565.0000	45.79	-3.22	42.57	74.00	-31.43	Peak
6	1565.0000	30.90	-3.22	27.68	54.00	-26.32	AVG
7	1890.0000	47.14	-3.35	43.79	74.00	-30.21	Peak
8	1890.0000	31.84	-3.35	28.49	54.00	-25.51	AVG
9	4050.0000	40.95	5.31	46.26	74.00	-27.74	Peak
10	4050.0000	25.89	5.31	31.20	54.00	-22.80	AVG
11	5177.5000	40.89	6.69	47.58	74.00	-26.42	Peak
12	5177.5000	25.65	6.69	32.34	54.00	-21.66	AVG

EUT	IP Phone	Model Name	X4
Temperature	25°C	Relative Humidity	60%
Test Voltage	AC 120V/60Hz	Polarization	Horizontal
Test Mode	Handset		
Note	Adapter		
Test Engineer	Pike Lee		

100 dBuV/m

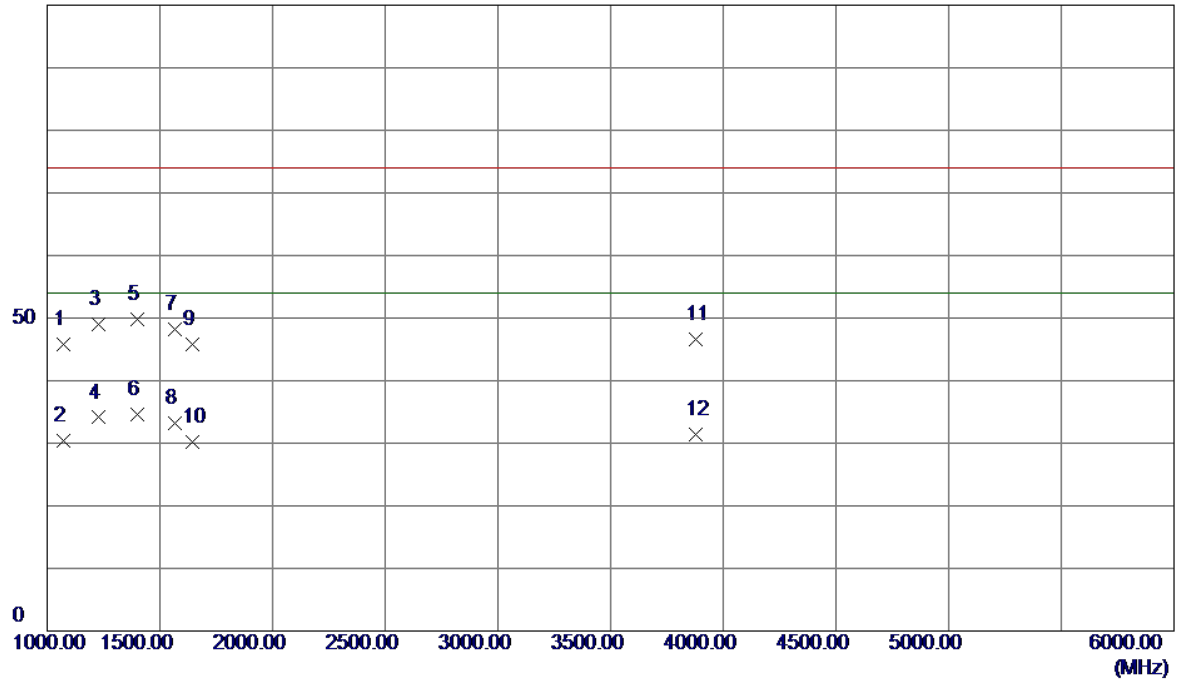

No.	Freq. MHz	Reading Level dBuV/m	Correct Factor dB	Measure ment dBuV/m	Limit dBuV/m	Margin dB	Detector
1	1070.0000	50.45	-4.62	45.83	74.00	-28.17	Peak
2	1070.0000	35.11	-4.62	30.49	54.00	-23.51	AVG
3	1227.5000	53.16	-4.10	49.06	74.00	-24.94	Peak
4	1227.5000	38.20	-4.10	34.10	54.00	-19.90	AVG
5	1400.0000	53.36	-3.53	49.83	74.00	-24.17	Peak
6 *	1400.0000	38.12	-3.53	34.59	54.00	-19.41	AVG
7	1567.5000	51.47	-3.23	48.24	74.00	-25.76	Peak
8	1567.5000	36.51	-3.23	33.28	54.00	-20.72	AVG
9	1645.0000	49.14	-3.26	45.88	74.00	-28.12	Peak
10	1645.0000	33.44	-3.26	30.18	54.00	-23.82	AVG
11	3880.0000	41.79	4.88	46.67	74.00	-27.33	Peak
12	3880.0000	26.61	4.88	31.49	54.00	-22.51	AVG

EUT	IP Phone	Model Name	X4
Temperature	25°C	Relative Humidity	60%
Test Voltage	DC 48V	Polarization	Vertical
Test Mode	Earphone		
Note	PoE		
Test Engineer	Pike Lee		

80 dBuV/m

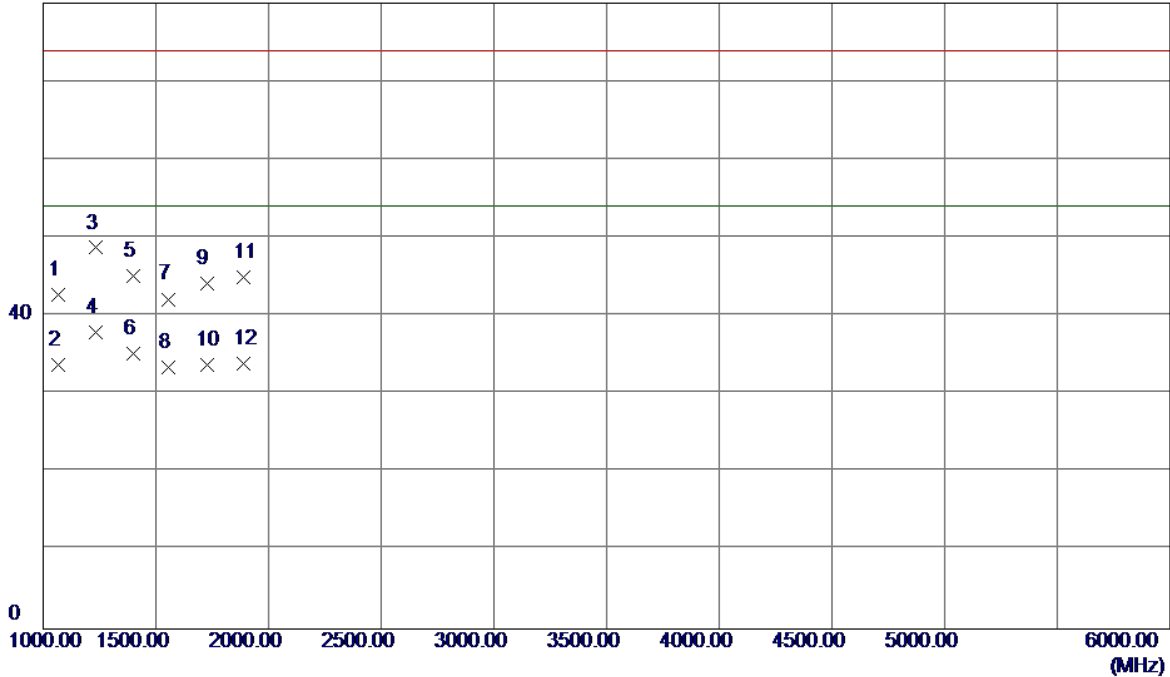

No.	Freq. MHz	Reading Level dBuV/m	Correct Factor dB	Measure ment dBuV/m	Limit dBuV/m	Margin dB	Detector
1	1065.0000	48.05	-5.35	42.70	74.00	-31.30	Peak
2	1065.0000	39.16	-5.35	33.81	54.00	-20.19	AVG
3	1235.0000	53.38	-4.66	48.72	74.00	-25.28	Peak
4 *	1235.0000	42.57	-4.66	37.91	54.00	-16.09	AVG
5	1400.0000	49.13	-3.99	45.14	74.00	-28.86	Peak
6	1400.0000	39.24	-3.99	35.25	54.00	-18.75	AVG
7	1555.0000	45.54	-3.38	42.16	74.00	-31.84	Peak
8	1555.0000	36.89	-3.38	33.51	54.00	-20.49	AVG
9	1725.0000	46.90	-2.76	44.14	74.00	-29.86	Peak
10	1725.0000	36.47	-2.76	33.71	54.00	-20.29	AVG
11	1890.0000	47.10	-2.16	44.94	74.00	-29.06	Peak
12	1890.0000	36.13	-2.16	33.97	54.00	-20.03	AVG

EUT	IP Phone	Model Name	X4
Temperature	25°C	Relative Humidity	60%
Test Voltage	DC 48V	Polarization	Horizontal
Test Mode	Earphone		
Note	PoE		
Test Engineer	Pike Lee		

80 dBuV/m

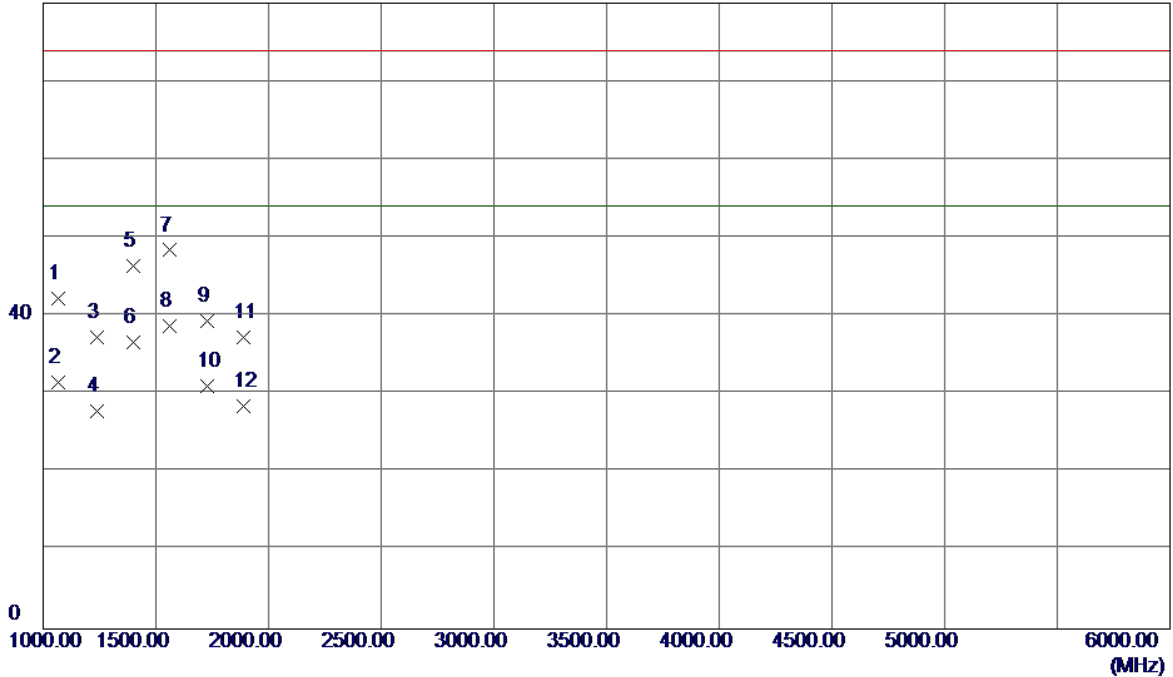

No.	Freq. MHz	Reading Level dBuV/m	Correct Factor dB	Measure ment dBuV/m	Limit dBuV/m	Margin dB	Detector
1	1065.0000	47.64	-5.35	42.29	74.00	-31.71	Peak
2	1065.0000	36.89	-5.35	31.54	54.00	-22.46	AVG
3	1240.0000	41.87	-4.64	37.23	74.00	-36.77	Peak
4	1240.0000	32.41	-4.64	27.77	54.00	-26.23	AVG
5	1400.0000	50.35	-3.99	46.36	74.00	-27.64	Peak
6	1400.0000	40.67	-3.99	36.68	54.00	-17.32	AVG
7	1560.0000	51.77	-3.37	48.40	74.00	-25.60	Peak
8 *	1560.0000	42.16	-3.37	38.79	54.00	-15.21	AVG
9	1730.0000	42.14	-2.75	39.39	74.00	-34.61	Peak
10	1730.0000	33.82	-2.75	31.07	54.00	-22.93	AVG
11	1890.0000	39.44	-2.16	37.28	74.00	-36.72	Peak
12	1890.0000	30.63	-2.16	28.47	54.00	-25.53	AVG

EUT	IP Phone	Model Name	X4
Temperature	25°C	Relative Humidity	60%
Test Voltage	AC 120V/60Hz	Polarization	Vertical
Test Mode	Earphone		
Note	Adapter		
Test Engineer	Pike Lee		

100 dBuV/m

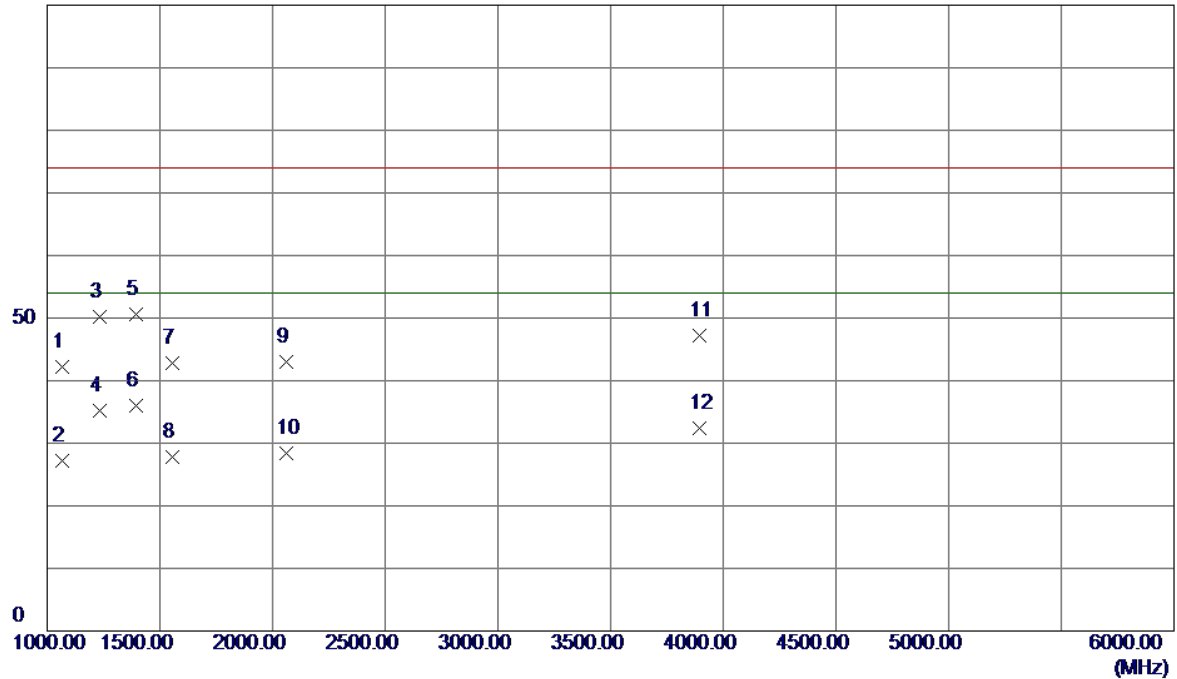

No.	Freq. MHz	Reading Level dBuV/m	Correct Factor dB	Measure ment dBuV/m	Limit dBuV/m	Margin dB	Detector
1	1067.5000	46.89	-4.63	42.26	74.00	-31.74	Peak
2	1067.5000	31.78	-4.63	27.15	54.00	-26.85	AVG
3	1235.0000	54.29	-4.07	50.22	74.00	-23.78	Peak
4	1235.0000	39.23	-4.07	35.16	54.00	-18.84	AVG
5	1392.5000	54.10	-3.55	50.55	74.00	-23.45	Peak
6 *	1392.5000	39.52	-3.55	35.97	54.00	-18.03	AVG
7	1557.5000	46.10	-3.22	42.88	74.00	-31.12	Peak
8	1557.5000	31.09	-3.22	27.87	54.00	-26.13	AVG
9	2060.0000	46.02	-2.95	43.07	74.00	-30.93	Peak
10	2060.0000	31.31	-2.95	28.36	54.00	-25.64	AVG
11	3895.0000	42.32	4.94	47.26	74.00	-26.74	Peak
12	3895.0000	27.52	4.94	32.46	54.00	-21.54	AVG

EUT	IP Phone	Model Name	X4
Temperature	25°C	Relative Humidity	60%
Test Voltage	AC 120V/60Hz	Polarization	Horizontal
Test Mode	Earphone		
Note	Adapter		
Test Engineer	Pike Lee		

100 dBuV/m

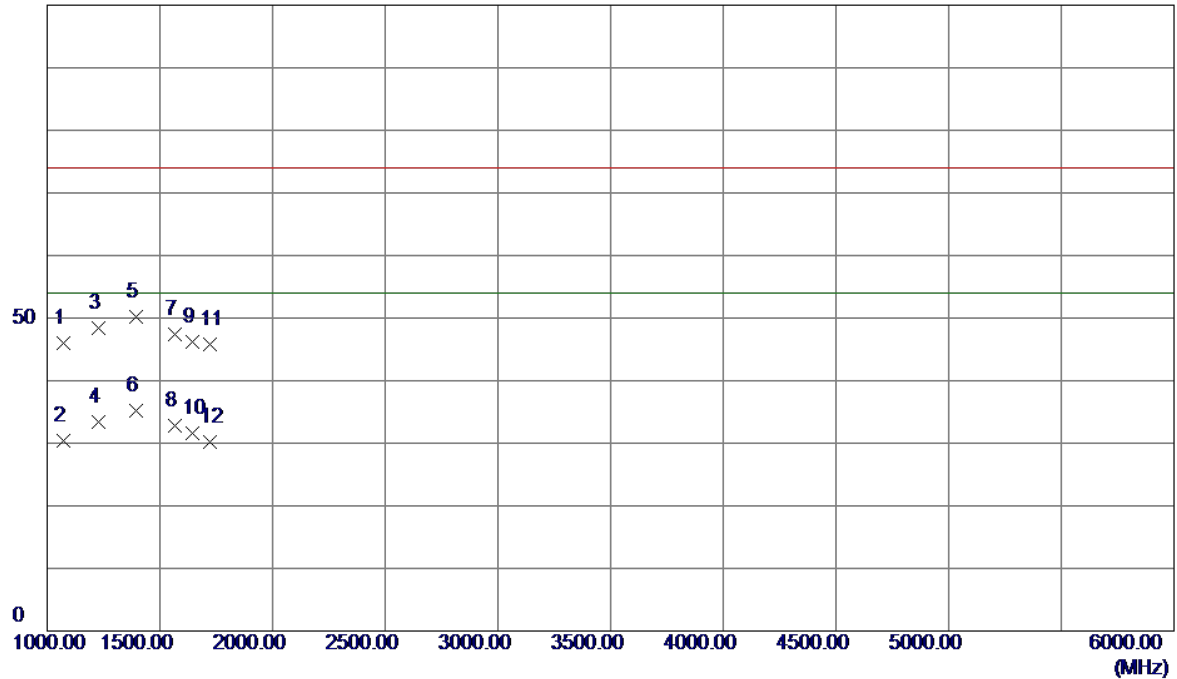

No.	Freq. MHz	Reading Level dBuV/m	Correct Factor dB	Measure ment dBuV/m	Limit dBuV/m	Margin dB	Detector
1	1070.0000	50.59	-4.62	45.97	74.00	-28.03	Peak
2	1070.0000	35.10	-4.62	30.48	54.00	-23.52	AVG
3	1230.0000	52.41	-4.09	48.32	74.00	-25.68	Peak
4	1230.0000	37.46	-4.09	33.37	54.00	-20.63	AVG
5	1395.0000	53.74	-3.55	50.19	74.00	-23.81	Peak
6 *	1395.0000	38.71	-3.55	35.16	54.00	-18.84	AVG
7	1565.0000	50.56	-3.22	47.34	74.00	-26.66	Peak
8	1565.0000	36.09	-3.22	32.87	54.00	-21.13	AVG
9	1642.5000	49.45	-3.25	46.20	74.00	-27.80	Peak
10	1642.5000	34.93	-3.25	31.68	54.00	-22.32	AVG
11	1720.0000	49.04	-3.28	45.76	74.00	-28.24	Peak
12	1720.0000	33.41	-3.28	30.13	54.00	-23.87	AVG