

EMC Test Report

Project No. : 1703C091
Equipment : IP Phone
Test Model : X4
Applicant : Fanvil Technology Co.Ltd
Address : 3F, Block A, Gaoxinqi Building, Anhua Industrial Park,
Qianjin 1st Rd. 35th Dist., Bao'An, Shenzhen, 518101,
China

Date of Receipt : Mar. 10, 2017
Date of Test : Mar. 13, 2017 ~ May 17, 2017
Issued Date : May 18, 2017
Tested by : BTL Inc.

Testing Engineer : Jason Yang
(Jason Yang)

Technical Manager : Bill Zhang
(Bill Zhang)

Authorized Signatory : Steven Lu
(Steven Lu)

B T L I N C .

No.3, Jinshagang 1st Road, Shixia, Dalang Town, Dongguan,
Guangdong, China.

TEL: +86-769-8318-3000 FAX: +86-769-8319-6000



Declaration

BTL represents to the client that testing is done in accordance with standard procedures as applicable and that test instruments used has been calibrated with standards traceable to international standard(s) and/or national standard(s).

BTL's reports apply only to the specific samples tested under conditions. It is manufacture's responsibility to ensure that additional production units of this model are manufactured with the identical electrical and mechanical components. **BTL** shall have no liability for any declarations, inferences or generalizations drawn by the client or others from **BTL** issued reports.

BTL's report must not be used by the client to claim product certification, approval, or endorsement by NVLAP, NIST, or any agency of the Federal Government.

This report is the confidential property of the client. As a mutual protection to the clients, the public and **BTL-self**, extracts from the test report shall not be reproduced except in full with **BTL's** authorized written approval.

BTL's laboratory quality assurance procedures are in compliance with the **ISO Guide 17025** requirements, and accredited by the conformity assessment authorities listed in this test report.

Limitation

For the use of the authority's logo is limited unless the Test Standard(s)/Scope(s)/Item(s) mentioned in this test report is (are) included in the conformity assessment authorities acceptance respective.

Table of Contents**Page**

REPORT ISSUED HISTORY	6
1 . CERTIFICATION	7
2 . SUMMARY OF TEST RESULTS	8
2.1 TEST FACILITY	10
2.2 MEASUREMENT UNCERTAINTY	10
3 . GENERAL INFORMATION	12
3.1 GENERAL DESCRIPTION OF EUT	12
3.2 DESCRIPTION OF TEST MODES	13
3.3 EUT OPERATING CONDITIONS	14
3.4 BLOCK DIAGRAM SHOWING THE CONFIGURATION OF SYSTEM TESTED	15
3.5 DESCRIPTION OF SUPPORT UNITS	16
4 . EMC EMISSION TEST	17
4.1 RADIATED EMISSION	17
4.1.1 LIMITS	17
4.1.2 MEASUREMENT INSTRUMENTS LIST	19
4.1.3 TEST PROCEDURE	20
4.1.4 DEVIATION FROM TEST STANDARD	21
4.1.5 TEST SETUP	21
4.1.6 MEASUREMENT DISTANCE	22
4.1.7 TEST RESULTS (UP TO 1 GHZ)	23
4.1.8 TEST RESULTS (ABOVE 1 GHZ)	35
4.2 CONDUCTED EMISSION MEASUREMENT AT AC MAINS POWER PORTS	47
4.2.1 LIMITS	47
4.2.2 MEASUREMENT INSTRUMENTS LIST	47
4.2.3 TEST PROCEDURE	48
4.2.4 DEVIATION FROM TEST STANDARD	48
4.2.5 TEST SETUP	48
4.2.6 TEST RESULTS	49
4.3 ASYMMETRIC MODE CONDUCTED EMISSIONS TEST	55
4.3.1 LIMITS	55
4.3.2 MEASUREMENT INSTRUMENTS LIST	57
4.3.3 TEST PROCEDURE	57
4.3.4 DEVIATION FROM TEST STANDARD	57
4.3.5 TEST SETUP	58
4.3.6 TEST RESULTS	59
4.4 HARMONIC CURRENT EMISSIONS TEST	67
4.4.1 LIMITS	67
4.4.2 MEASUREMENT INSTRUMENTS LIST	67

Table of Contents

Page

4.4.3 TEST PROCEDURE	68
4.4.4 DEVIATION FROM TEST STANDARD	68
4.4.5 TEST SETUP	68
4.4.6 TEST RESULTS	69
4.5 VOLTAGE CHANGES, VOLTAGE FLUCTUATIONS AND FLICKER TEST	72
4.5.1 LIMITS	72
4.5.2 MEASUREMENT INSTRUMENTS LIST	72
4.5.3 TEST PROCEDURE	72
4.5.4 DEVIATION FROM TEST STANDARD	72
4.5.5 TESTSETUP	73
4.5.6 TEST RESULTS	74
5 . EMC IMMUNITY TEST	75
5.1 STANDARD COMPLIANCE/SEVERITY LEVEL/CRITERIA	75
5.2 GENERAL PERFORMANCE CRITERIA	77
5.3 ELECTROSTATIC DISCHARGE IMMUNITY TEST (ESD)	78
5.3.1 TEST SPECIFICATION	78
5.3.2 MEASUREMENT INSTRUMENTS	78
5.3.3 TEST PROCEDURE	78
5.3.4 DEVIATION FROM TEST STANDARD	79
5.3.5 TEST SETUP	79
5.3.6 TEST RESULTS	80
5.4 RADIATED, RADIO-FREQUENCY, ELECTROMAGNETIC FIELD IMMUNITY TEST (RS)	84
5.4.1 TEST SPECIFICATION	84
5.4.2 MEASUREMENT INSTRUMENTS	84
5.4.3 TEST PROCEDURE	84
5.4.4 DEVIATION FROM TEST STANDARD	84
5.4.5 TEST SETUP	85
5.4.6 TEST RESULTS	86
5.5 ELECTRICAL FAST TRANSIENT/BURST IMMUNITY TEST (EFT/BURST)	87
5.5.1 TEST SPECIFICATION	87
5.5.2 MEASUREMENT INSTRUMENTS	87
5.5.3 TEST PROCEDURE	87
5.5.4 DEVIATION FROM TEST STANDARD	87
5.5.5 TEST SETUP	88
5.5.6 TEST RESULTS	89
5.6 SURGE IMMUNITY TEST	90
5.6.1 TEST SPECIFICATION	90
5.6.2 MEASUREMENT INSTRUMENTS	90
5.6.3 TEST PROCEDURE	91
5.6.4 DEVIATION FROM TEST STANDARD	91

Table of Contents	Page
5.6.5 TEST SETUP	91
5.6.6 TEST RESULTS	92
5.7 IMMUNITY TO CONDUCTED DISTURBANCES, INDUCED BY	
RADIO-FREQUENCY FIELDS TEST (CS)	93
5.7.1 TEST SPECIFICATION	93
5.7.2 MEASUREMENT INSTRUMENTS	93
5.7.3 TEST PROCEDURE	93
5.7.4 DEVIATION FROM TEST STANDARD	93
5.7.5 TEST SETUP	94
5.7.6 TEST RESULTS	95
5.8 POWER FREQUENCY MAGNETIC FIELD IMMUNITY TEST (PFMF)	96
5.8.1 TEST SPECIFICATION	96
5.8.2 MEASUREMENT INSTRUMENTS	96
5.8.3 TEST PROCEDURE	96
5.8.4 DEVIATION FROM TEST STANDARD	96
5.8.5 TEST SETUP	97
5.8.6 TEST RESULTS	98
5.9 VOLTAGE DIPS, SHORT INTERRUPTIONS AND VOLTAGE VARIATIONS	
IMMUNITY TEST	99
5.9.1 TEST SPECIFICATION	99
5.9.2 MEASUREMENT INSTRUMENTS	99
5.9.3 TEST PROCEDURE	99
5.9.4 DEVIATION FROM TEST STANDARD	99
5.9.5 TEST SETUP	100
5.9.6 TEST RESULTS	101
6 . EUT TEST PHOTO	102

REPORT ISSUED HISTORY

Issued No.	Description	Issued Date
BTL-EMC-1-1703C091	Original Issue.	May 18, 2017

1. CERTIFICATION

Equipment : IP Phone
Brand Name : Fanvil
Test Model : X4
Applicant : Fanvil Technology Co.Ltd
Manufacturer : Fanvil Technology Co.Ltd
Address : 3F, Block A, Gaoxinqi Building, Anhua Industrial Park, Qianjin 1st Rd. 35th
Dist., Bao'An, Shenzhen, 518101, China
Factory : Fanvil Technology Co.Ltd
Address : 3F, Block A, Gaoxinqi Building, Anhua Industrial Park, Qianjin 1st Rd. 35th
Dist., Bao'An, Shenzhen, 518101, China
Date of Test : Mar. 13, 2017 ~ May. 17, 2017
Test Sample : Engineering Sample
Standard(s) : EN 55032: 2015 Class B
EN 61000-3-2: 2014 Class A
EN 61000-3-3: 2013
EN 55024:2010+A1:2015
EN 61000-4-2: 2009
EN 61000-4-3: 2006+A1:2008+A2:2010
EN 61000-4-4: 2012
EN 61000-4-5: 2014
EN 61000-4-6: 2014+AC:2015
EN 61000-4-8: 2010
EN 61000-4-11: 2004

The above equipment has been tested and found compliance with the requirement of the relative standards by BTL Inc.

The test data, data evaluation, and equipment configuration contained in our test report (Ref No. BTL-EMC-1-1703C091) were obtained utilizing the test procedures, test instruments, test sites that has been accredited by the Authority of TAF according to the ISO-17025 quality assessment standard and technical standard(s).

2. SUMMARY OF TEST RESULTS

Test procedures according to the technical standards:

Emission					
Standard(s)	Test Item	Limit	Judgment	Remark	
EN 55032: 2015	Radiated emissions up to 1 GHz	Class B	PASS	-----	
	Radiated emissions above 1 GHz	Class B	PASS	NOTE (2)	
	Radiated emissions from FM receivers	-----	N/A	NOTE (1) NOTE (6)	
	Conducted emissions AC mains power port	Class B	PASS	NOTE (7)	
	Asymmetric mode conducted emissions	AAN	-----	PASS	NOTE (1) NOTE (8)
		Current Probe	-----	N/A	
		CVP	-----	N/A	
Conducted differential voltage emissions	-----	N/A	NOTE (1) NOTE (9)		

Standard	Test Item	Limit	Judgment	Remark
EN 61000-3-2:2014	Harmonic current emissions	Class A	PASS	NOTE (3)
EN 61000-3-3:2013	Voltage changes, voltage fluctuations and flicker	-----	PASS	

Immunity EN 55024: 2010+A1:2015				
Section(s)	Test Item	Performance Criterion	Judgment	Remark
EN 61000-4-2:2009	Electrostatic discharge immunity	B	PASS	
EN 61000-4-3: 2006+A1:2008+A2:2010	Radiated, radio-frequency, electromagnetic field immunity	A	PASS	
EN 61000-4-4:2012	Electrical fast transient/burst immunity	B	PASS	
EN 61000-4-5:2014	Surge immunity	B/C	PASS	NOTE (4)
EN 61000-4-6: 2014+AC:2015	Immunity to conducted disturbances, induced by radio-frequency fields	A	PASS	
EN 61000-4-8:2010	Power frequency magnetic field immunity	A	PASS	
EN 61000-4-11:2004	Voltage dips, short interruptions and voltage variations immunity	B / C / C	PASS	NOTE (5)

NOTE:

- (1) "N/A" denotes test is not applicable to this device.
- (2) The EUT's max operating frequency is 166 MHz which does exceed 108 MHz, so the test will be performed.
- (3) If the power consumption is less than 75W, there is no limit applied.
- (4) Performance Criterion C for signal ports and telecommunication ports.
Performance Criterion B for input d.c. power port and a.c. power ports.
- (5) Voltage Dips: >95% reduction – Performance Criterion B
Voltage Dips: 30% reduction – Performance Criterion C
Voltage Interruptions: >95% reduction – Performance Criterion C
- (6) If the EUT has FM function the test will be performed.
- (7) If the EUT has AC power mains port the test will be performed.
- (8)

Cable Type	Number of pairs	Measurement type	Procedures
Balanced Unscreened	1 (2 wire) ;2 (4 wire); 3 (6 wire) ;4 (8 wire)	Voltage	AAN
Balanced Unscreened	See a)	Voltage and Current	CP+CVP
Screened or Coaxial	n/a	Voltage	AAN
Screened or Coaxial	n/a	Voltage or Current	CP or CVP
Unbalanced cables	n/a	Voltage and Current	CP+CVP

Ports connected to cables with more than 4 balanced pairs or where the port is unable to function correctly when connected through an AAN.

- (9) If the EUT has tuner port the test will be performed.
- (10) The requirement followed by the client's specification.

2.1 TEST FACILITY

The test facilities used to collect the test data in this report is at the location of No.3, Jinshagang 1st Road, Shixia, Dalang Town, Dongguan, Guangdong, China.

2.2 MEASUREMENT UNCERTAINTY

Where relevant, the following measurement uncertainty levels have been estimated for tests performed on the EUT as specified in CISPR 16-4-2, The BTL measurement uncertainty is less than the CISPR 16-4-2 U_{CISPR} requirement.

The reported uncertainty of measurement $y \pm U$, where expanded uncertainty U is based on a standard uncertainty multiplied by a coverage factor of $k=2$, providing a level of confidence of approximately **95%**.

A. Radiated emissions up to 1 GHz measurement:

Test Site	Method	Measurement Frequency Range	Ant. H / V	U, (dB)
DG-CB02 (3m)	CISPR	30MHz ~ 200MHz	V	3.83
		30MHz ~ 200MHz	H	3.79
		200MHz ~ 1,000MHz	V	4.04
		200MHz ~ 1,000MHz	H	4.02

B. Radiated emissions above 1 GHz measurement:

Test Site	Method	Measurement Frequency Range	U, (dB)
DG-CB02 (3m)	CISPR	1 ~ 6 GHz	4.50
		6 ~ 18 GHz	5.18

C. Conducted Emissions AC Mains Power Port Measurement:

Test Site	Method	Measurement Frequency Range	U, (dB)
DG-C01	CISPR	150 kHz ~ 30MHz	3.16

D. Asymmetric Mode Conducted Emissions Measurement:

Test Site	Method	Measurement Frequency Range	U, (dB)
DG-C01	CISPR	AAN 50...40dB	3.76
		AAN 65...50dB	3.76
		AAN 75...60dB	3.76
		Capacitive Voltage Probe	3.04
		RF Current Probe	2.58

E. Harmonic current emissions / Voltage changes, voltage fluctuations and flicker measurement:

Test Site	Method	Measurement Frequency Range	U, (dB)
DG-C01	EN 61000-3-2	Voltage	0.774
	EN 61000-3-3	Current	0.782

F. Immunity Measurement:

Test Site	Method	Measurement Frequency Range	U, (dB)
DG-SR02	EN 61000-4-2	Voltage(2kV/4kV/6kV/8kV/15kV/25kV/30kV)	1.0%
		Peak Current	6.0%
		30/60ns Current	6.0%
		Rise time	6.4%
DG-CB05	EN 61000-4-3	80MHz~1GHz	2.175 dB
DG-SR05	EN 61000-4-4	Impulse Voltage	4.0 %
		Impulse Rise Time	4.5 %
		Impulse duration Time	4.0 %
DG-SR05	EN 61000-4-5	Impulse Voltage	4.0 %
		Impulse Rise Time	4.5 %
		Impulse duration Time	4.0 %
DG-CB06	EN 61000-4-6	CDN: 150kHz~230MHz	2.509 dB
		EM Clamp: 150kHz~230MHz	3.094 dB
DG-SR05	EN 61000-4-8	Magnetic Field Level	3 %
DG-SR05	EN 61000-4-11	Impulse Amplitude	4 %
		Timing	3 %

Note: Unless specifically mentioned, the uncertainty of measurement has not been taken into account to declare the compliance or non-compliance to the specification.

3. GENERAL INFORMATION

3.1 GENERAL DESCRIPTION OF EUT

Equipment	IP Phone
Brand Name	Fanvil
Test Model	X4
Model Difference	N/A
Power Source	1)DC Voltage supplied from AC/DC adapter. 2)Supplied from PoE.
Power Rating	1)I/P: 100-240V~50/60Hz 0.2A, O/P: DC 5V600mA 2)DC 48V

Note:

1. For a more detailed features description, please refer to the manufacturer's specifications or the user's manual.

3.2 DESCRIPTION OF TEST MODES

To investigate the maximum EMI emission characteristics generates from EUT, the test system was pre-scanning tested base on the consideration of following EUT operation mode or test configuration mode which possible have effect on EMI emission level. Each of these EUT operation mode(s) or test configuration mode(s) mentioned above was evaluated respectively.

Pretest Mode	Description
Mode 1	Handfree
Mode 2	Handset
Mode 3	Earphone
Mode 4	PC Port 100Mbps
Mode 5	PC Port 10Mbps
Mode 6	Internet Port 100Mbps
Mode 7	Internet Port 10Mbps

For Radiated Test	
Final Test Mode	Description
Mode 1	Handfree
Mode 2	Handset
Mode 3	Earphone

For Conducted Test	
Final Test Mode	Description
Mode 1	Handfree
Mode 2	Handset
Mode 3	Earphone

For ISN Test	
Final Test Mode	Description
Mode 4	PC Port 100Mbps
Mode 5	PC Port 10Mbps
Mode 6	Internet Port 100Mbps
Mode 7	Internet Port 10Mbps

For Harmonics / Flicks Test	
Final Test Mode	Description
Mode 1	Handfree

For EMS Test	
Final Test Mode	Description
Mode 1	Handfree
Mode 2	Handset
Mode 3	Earphone

3.3 EUT OPERATING CONDITIONS

The EUT exercise program used during radiated and/or conducted emission measurement was designed to exercise the various system components in a manner similar to a typical use.

3.4 BLOCK DIAGRAM SHOWING THE CONFIGURATION OF SYSTEM TESTED

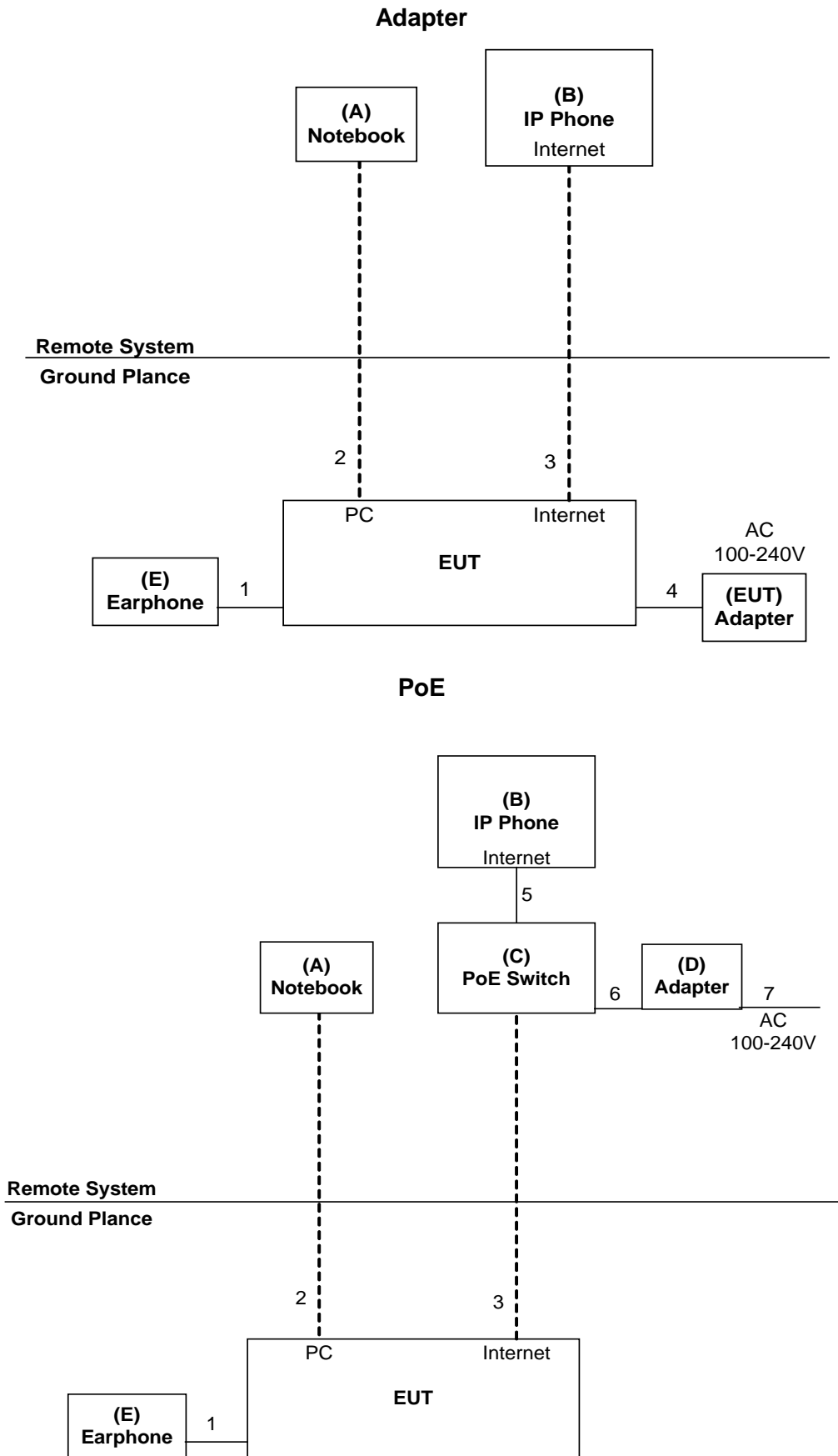

3.5 DESCRIPTION OF SUPPORT UNITS

The EUT has been tested as an independent unit together with other necessary accessories or support units. The following support units or accessories were used to form a representative test configuration during the tests.

Item	Equipment	Mfr/Brand	Model/Type No.	FCC ID	Series No.
A	Notebook	Lenovo	G40	DOC	YB09261386
B	IP Phone	Fanvil	X3SP	N/A	1000HF7371004260
C	PoE Switch	Fanvil	DGS-1008P/Dlink	N/A	N/A
D	Adapter	Leader	NU60-F4B0125-I1NN	N/A	N/A
E	Earphone	Fanvil	A310QD	N/A	N/A

Item	Shielded Type	Ferrite Core	Length	Note
1	NO	NO	1m	RJ11 Cable
2	NO	NO	10m	RJ45 Cable
3	NO	NO	10m	RJ45 Cable
4	NO	NO	1.5m	DC Cable
5	NO	NO	1.8m	RJ45 Cable
6	NO	YES	1.5m	DC Cable
7	NO	NO	1.8m	AC Cable

4. EMC EMISSION TEST

4.1 RADIATED EMISSION

4.1.1 LIMITS

Class A equipment up to 1000MHz

Table clause	Frequency range MHz	Measurement			Class A limits dB(μ V/m)
		Facility (see Table A.1)	Distance m	Detector type/ bandwidth	
A2.1	30-230	OATS/SAC	10	Quasi peak / 120 kHz	40
	230-1000				47
A2.2	30-230	OATS/SAC	3		50
	230-1000				57
A2.3	30-230	FAR	10	42 to 35	
	230-1000			42	
A2.4	30-230	FAR	3	52 to 45	
	230-1000			52	

Apply only A2.1 or A2.2 or A2.3 or A2.4 across the entire frequency range.

Class A equipment above 1000MHz

Table clause	Frequency range MHz	Measurement			Class A limits dB(μ V/m)
		Facility (see Table A.1)	Distance m	Detector type/ bandwidth	
A3.1	1000-3000	FSOATS	3	Average / 1 MHz	56
	3000-6000				60
A3.2	1000-3000			Peak / 1 MHz	76
	3000-6000				80

Apply A3.1 and A3.2 across the frequency range from 1 000 MHz to the highest required frequency of measurement derived from Table 1.

Class B equipment up to 1000MHz

Table clause	Frequency range MHz	Measurement			Class B limits dB(μV/m)
		Facility (see Table A.1)	Distance m	Detector type/ bandwidth	
A4.1	30-230	OATS/SAC	10	Quasi peak / 120 kHz	30
	230-1000				37
A4.2	30-230	OATS/SAC	3		40
	230-1000				47
A4.3	30-230	FAR	10	32 to 25	
	230-1000			32	
A4.4	30-230	FAR	3	42 to 35	
	230-1000			42	

Apply only table clause A4.1 or A4.2 or A4.3 or A4.4 across the entire frequency range. These requirements are not applicable to the local oscillator and harmonics frequencies of equipment covered by Table A.6.

Class B equipment above 1000MHz

Table clause	Frequency range MHz	Measurement			Class B limits dB(μV/m)
		Facility (see Table A.1)	Distance m	Detector type/ bandwidth	
A5.1	1000-3000	FSOATS	3	Average / 1 MHz	50
	3000-6000				54
A5.2	1000-3000			Peak / 1 MHz	70
	3000-6000				74

Apply A5.1 and A5.2 across the frequency range from 1 000 MHz to the highest required frequency of measurement derived from Table 1.

Notes:

- (1) The limit for radiated test was performed according to as following: EN 55032
- (2) The tighter limit applies at the band edges.
- (3) Emission level (dBUV/m)=20log Emission level (uV/m).
- (4) The test result calculated as following:
 Measurement Value = Reading Level + Correct Factor
 Correct Factor = Antenna Factor + Cable Loss - Amplifier Gain(if use)
 Margin Level = Measurement Value - Limit Value

Required highest frequency for radiated measurement

Highest internal frequency (F _x) MHz	Highest measured frequency MHz
F _x ≤ 108	1000
108 < F _x ≤ 500	2000
500 < F _x ≤ 1000	5000
F _x > 1000	5 th up to a maximum 6 GHz,

Note for FM and TV broadcast receiver, F_x is determined from the highest frequency generated or used excluding the local oscillator and tuned frequencies.

4.1.2 MEASUREMENT INSTRUMENTS LIST

Up to 1GHz:

Item	Kind of Equipment	Manufacturer	Type No.	Serial No.	Calibrated until
1	Antenna	Schwarbeck	VULB9160	9160-3232	Mar. 26, 2018
2	Amplifier	Agilent	8449B	3008A02274	Feb. 22, 2018
3	Amplifier	HP	8447D	1937A02847	Feb. 22, 2018
4	RF Pre-selector	Agilent	N9039A	MY46520201	Sep. 04, 2017
5	Cable	emci	LMR-400(30MHz-1GHz)(10m+2.5m)	N/A	Jun. 27, 2017
6	Cable	emci	EMC104-SM-SM-10000 (1GHz-26.5GHz)(10m)	N/A	Jun. 30, 2017
7	Controller	CT	SC100	N/A	N/A
8	Measurement Software	Farad	EZ-EMC Ver.NB-03A1-01	N/A	N/A
9	Spectrum Analyzer	Agilent	E4447A	MY48250208	Sep. 04, 2017

Remark: "N/A" denotes no model name, no serial no. or no calibration specified.
All calibration period of equipment list is one year.

Above 1GHz:

Item	Kind of Equipment	Manufacturer	Type No.	Serial No.	Calibrated until
1	Antenna	Schwarbeck	VULB9160	9160-3232	Mar. 26, 2018
2	Amplifier	Agilent	8449B	3008A02274	Feb. 22, 2018
3	Amplifier	HP	8447D	1937A02847	Feb. 22, 2018
4	RF Pre-selector	Agilent	N9039A	MY46520201	Sep. 04, 2017
5	Cable	emci	LMR-400(30MHz-1GHz)(10m+2.5m)	N/A	Jun. 27, 2017
6	Cable	emci	EMC104-SM-SM-10000 (1GHz-26.5GHz)(10m)	N/A	Jun. 30, 2017
7	Controller	CT	SC100	N/A	N/A
8	Measurement Software	Farad	EZ-EMC Ver.NB-03A1-01	N/A	N/A
9	Spectrum Analyzer	Agilent	E4447A	MY48250208	Sep. 04, 2017

Remark: "N/A" denotes no model name, no serial no. or no calibration specified.
All calibration period of equipment list is one year.

4.1.3 TEST PROCEDURE

- a. The measuring distance of 3 m shall be used for measurements. The EUT was placed on the top of a rotating table 0.8 meter above the ground at a 3 meter semi-anechoic chamber. The table was rotated 360 degrees to determine the position of the highest radiation.(below 1GHz).
- b. The measuring distance of 3 m shall be used for measurements. The EUT was placed on the top of a rotating table 0.8 meter above the ground at a 3 meter semi-anechoic chamber. The table was rotated 360 degrees to determine the position of the highest radiation.(above 1GHz)
- c. The height of the equipment or of the substitution antenna shall be 0.8 m, the height of the test antenna shall vary between 1 m to 4 m. Both horizontal and vertical polarizations of the antenna are set to make the measurement.
- d. The initial step in collecting radiated emission data is a receiver peak detector mode pre-scanning the measurement frequency range. Significant peaks are then marked and then Quasi Peak detector mode re-measured.
- e. All readings are Peak unless otherwise stated QP in column of Note. Peak denotes that the Peak reading compliance with the QP Limits and then QP Mode measurement didn't perform. (below 1GHz)
- f. All readings are Peak Mode value unless otherwise stated AVG in column of Note. If the Peak Mode Measured value compliance with the Peak Limits and lower than AVG Limits, the EUT shall be deemed to meet both Peak & AVG Limits and then only Peak Mode was measured, but AVG Mode didn't perform. (above 1GHz)
- g. For the actual test configuration, please refer to the related Item - Block Diagram of system tested (please refer to 3.3).

4.1.4 DEVIATION FROM TEST STANDARD

No deviation

4.1.5 TEST SETUP

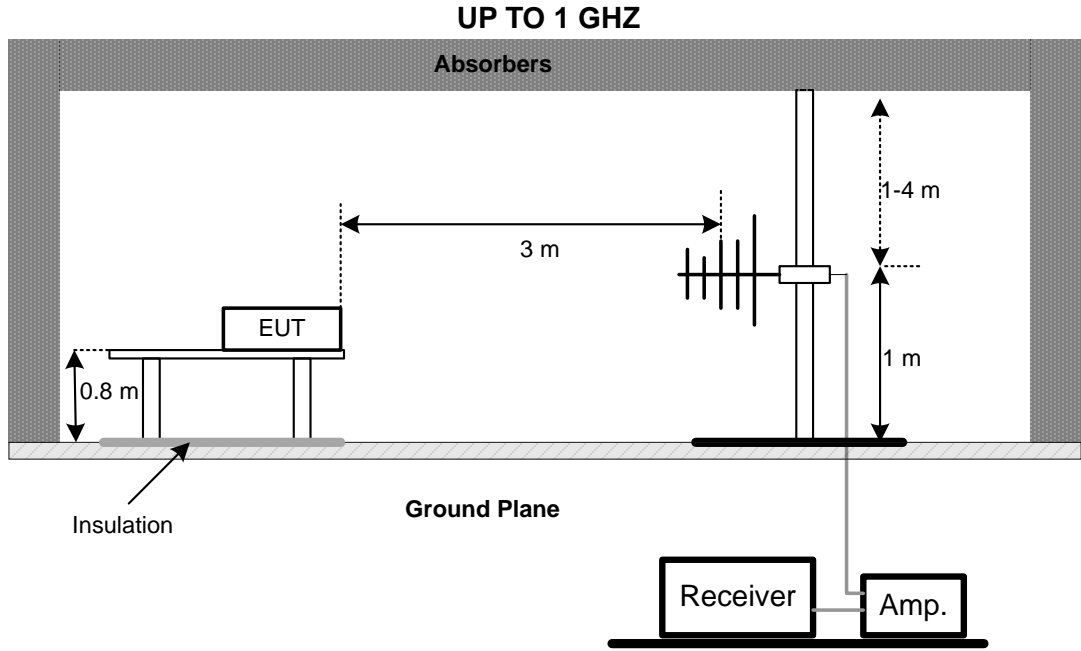

Note: The antenna can be moved between 1 to 4 meters above the ground.

ABOVE 1 GHZ

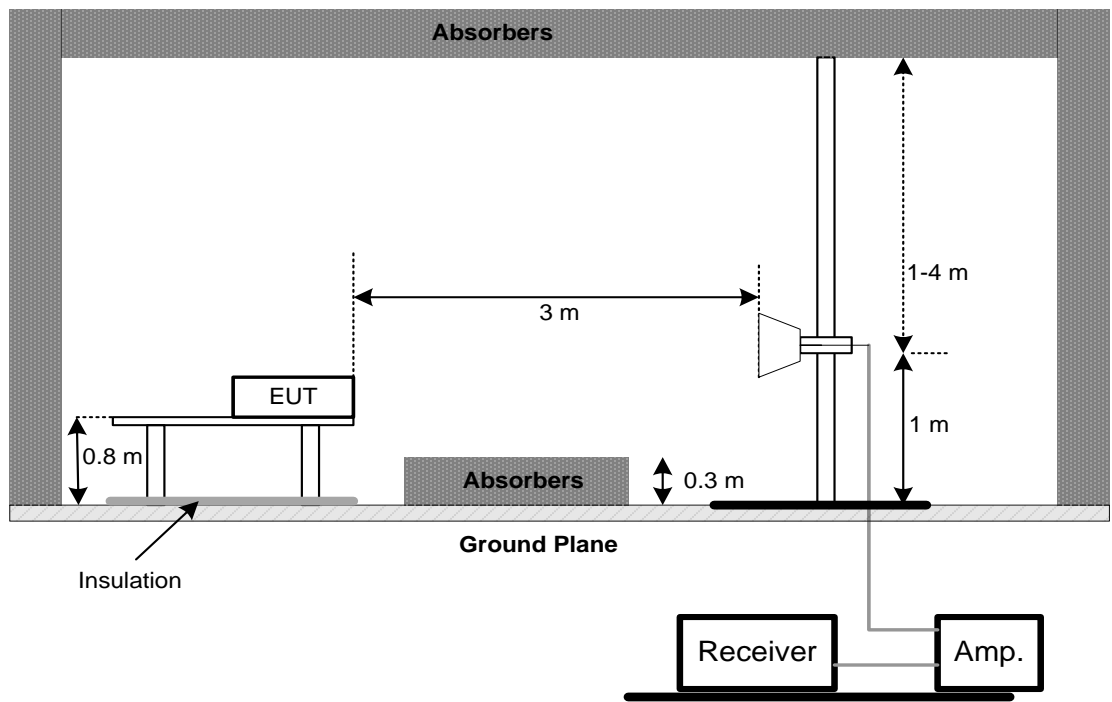

4.1.6 MEASUREMENT DISTANCE

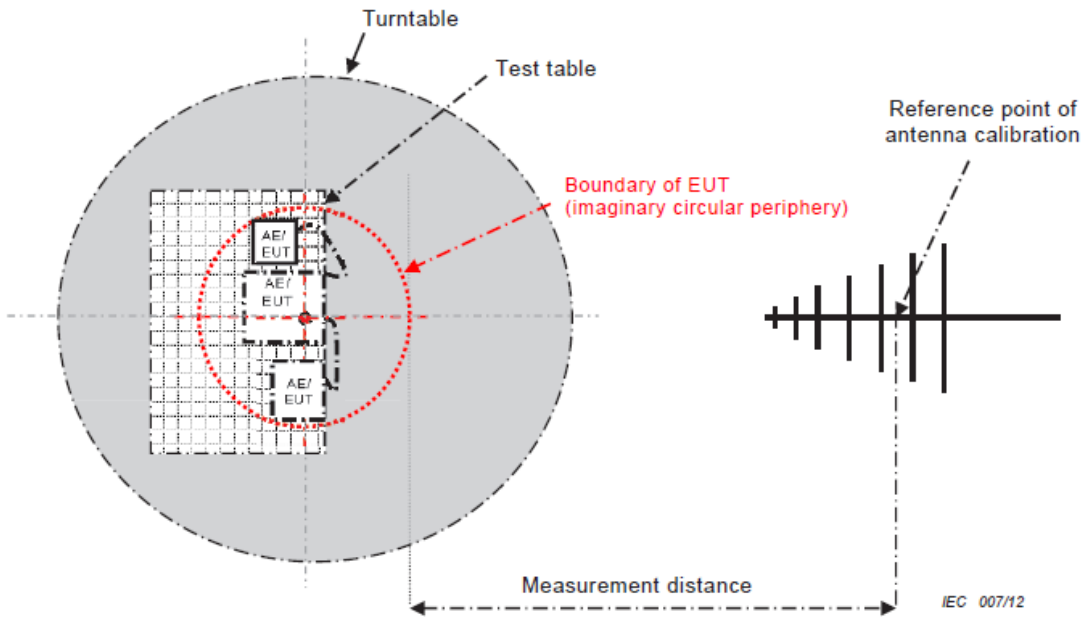

- 34 -

CISPR 32 © IEC:2012

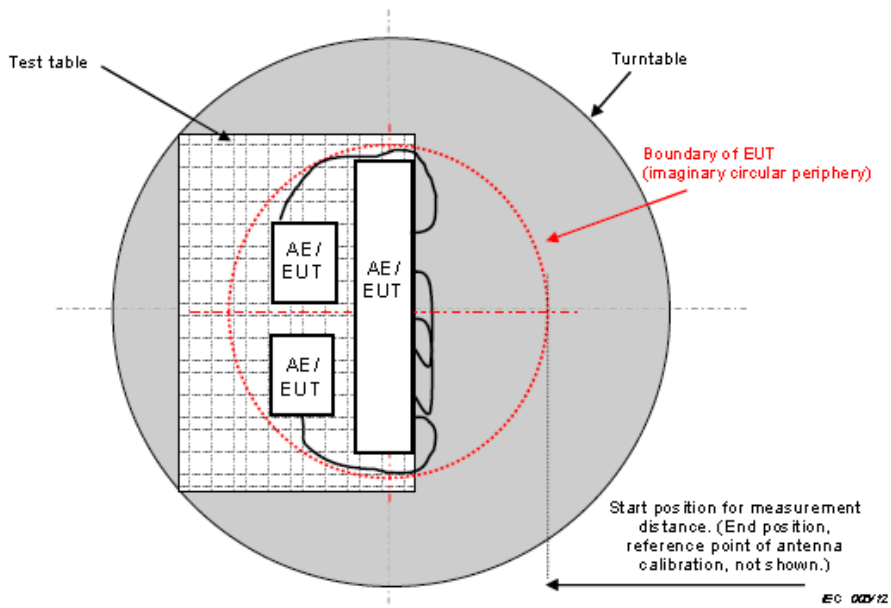
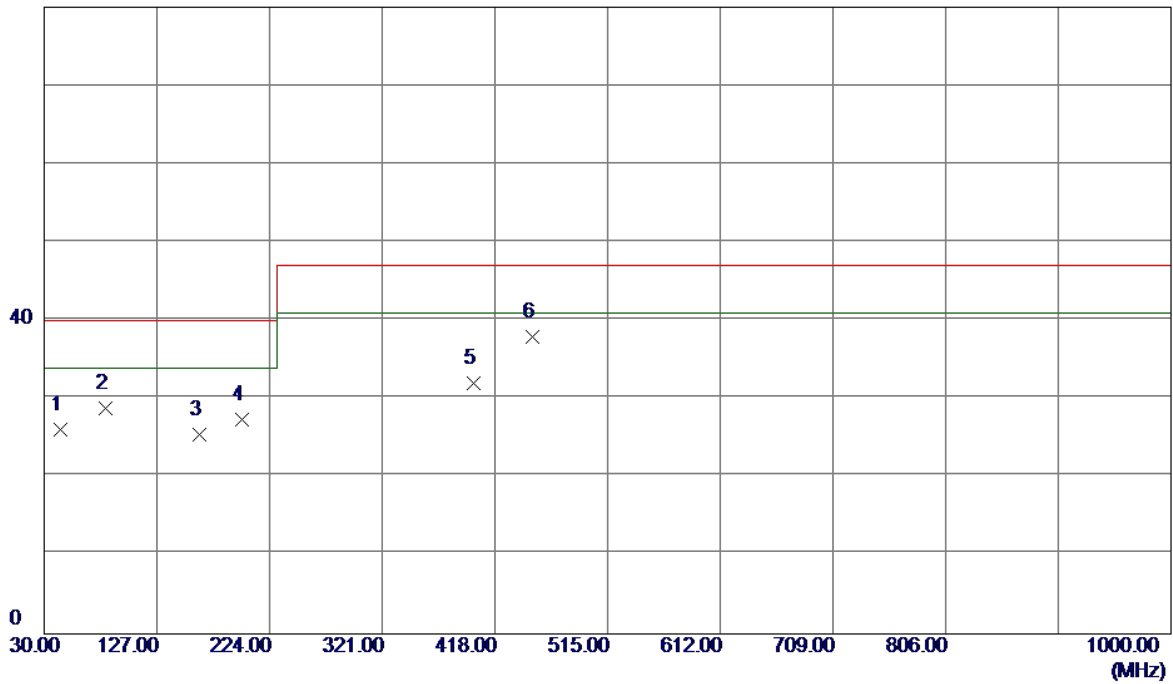

Figure C.2 – Boundary of EUT, Local AE and associated cabling

4.1.7 TEST RESULTS (UP TO 1 GHZ)

EUT	IP Phone	Model Name	X4
Temperature	25°C	Relative Humidity	60%
Test Voltage	AC 230V/50Hz	Polarization	Vertical
Test Mode	Handfree		
Note	Adapter		
Test Engineer	Jason Yang		

80 dBuV/m



No.	Freq. MHz	Reading Level dBuV/m	Correct Factor dB	Measure ment dBuV/m	Limit dBuV/m	Margin dB	Detector
1	43.5800	38.14	-12.07	26.07	40.00	-13.93	QP
2	82.3800	45.59	-16.86	28.73	40.00	-11.27	QP
3	163.8600	36.83	-11.36	25.47	40.00	-14.53	QP
4	200.7200	39.56	-12.20	27.36	40.00	-12.64	QP
5	399.5700	40.20	-8.22	31.98	47.00	-15.02	QP
6 *	450.0100	44.83	-6.98	37.85	47.00	-9.15	QP

EUT	IP Phone	Model Name	X4
Temperature	25°C	Relative Humidity	60%
Test Voltage	AC 230V/50Hz	Polarization	Horizontal
Test Mode	Handfree		
Note	Adapter		
Test Engineer	Jason Yang		

80 dBuV/m

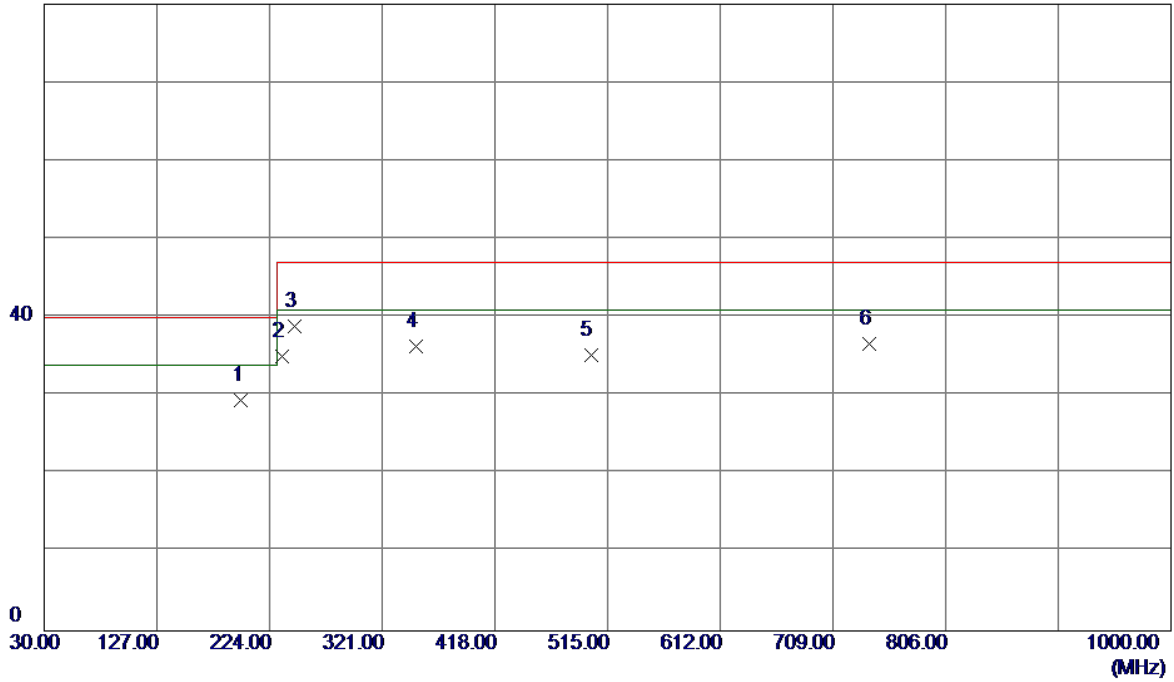

No.	Freq. MHz	Reading Level dBuV/m	Correct Factor dB	Measure ment dBuV/m	Limit dBuV/m	Margin dB	Detector
1	199.7500	41.62	-12.11	29.51	40.00	-10.49	QP
2	234.6700	48.34	-13.29	35.05	47.00	-11.95	QP
3 *	245.3400	52.16	-13.30	38.86	47.00	-8.14	QP
4	350.1000	45.80	-9.48	36.32	47.00	-10.68	QP
5	500.4500	41.10	-5.84	35.26	47.00	-11.74	QP
6	740.0400	37.03	-0.33	36.70	47.00	-10.30	QP

EUT	IP Phone	Model Name	X4
Temperature	25°C	Relative Humidity	60%
Test Voltage	DC 48V	Polarization	Vertical
Test Mode	Handfree		
Note	PoE		
Test Engineer	Jason Yang		

80 dBuV/m

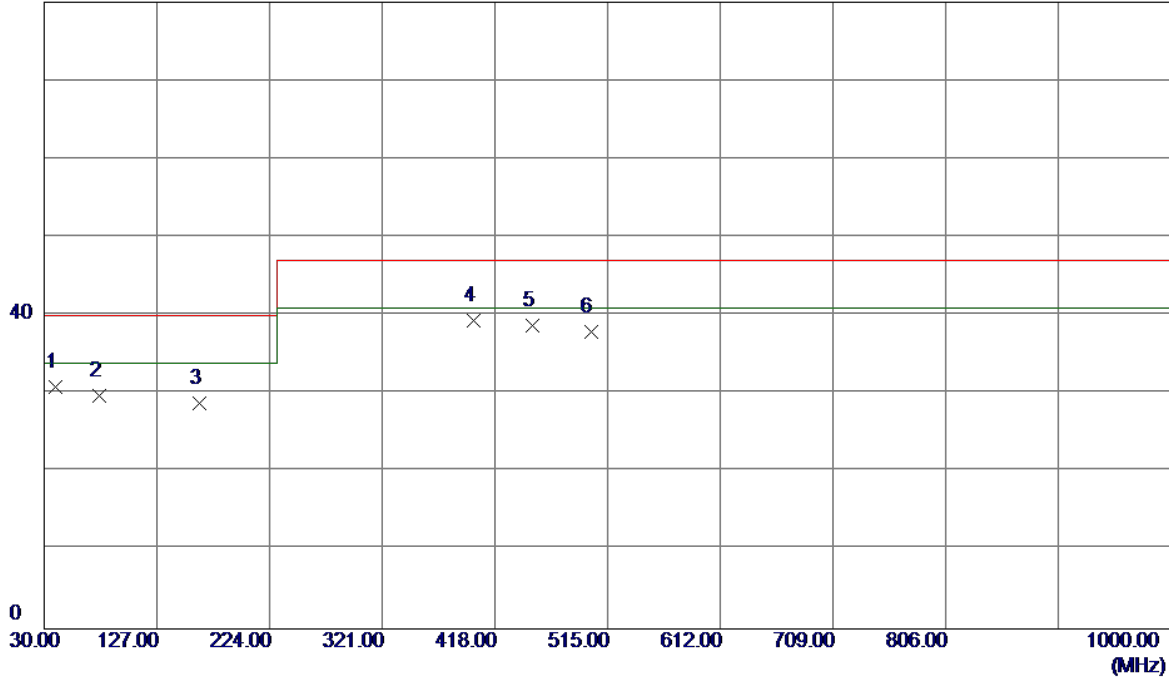

No.	Freq. MHz	Reading Level dBuV/m	Correct Factor dB	Measure ment dBuV/m	Limit dBuV/m	Margin dB	Detector
1	39.7000	43.64	-12.71	30.93	40.00	-9.07	QP
2	77.5300	45.95	-16.20	29.75	40.00	-10.25	QP
3	163.8600	40.16	-11.36	28.80	40.00	-11.20	QP
4 *	399.5700	47.64	-8.22	39.42	47.00	-7.58	QP
5	450.0100	45.67	-6.98	38.69	47.00	-8.31	QP
6	500.4500	43.79	-5.84	37.95	47.00	-9.05	QP

EUT	IP Phone	Model Name	X4
Temperature	25°C	Relative Humidity	60%
Test Voltage	DC 48V	Polarization	Horizontal
Test Mode	Handfree		
Note	PoE		
Test Engineer	Jason Yang		

80 dBuV/m

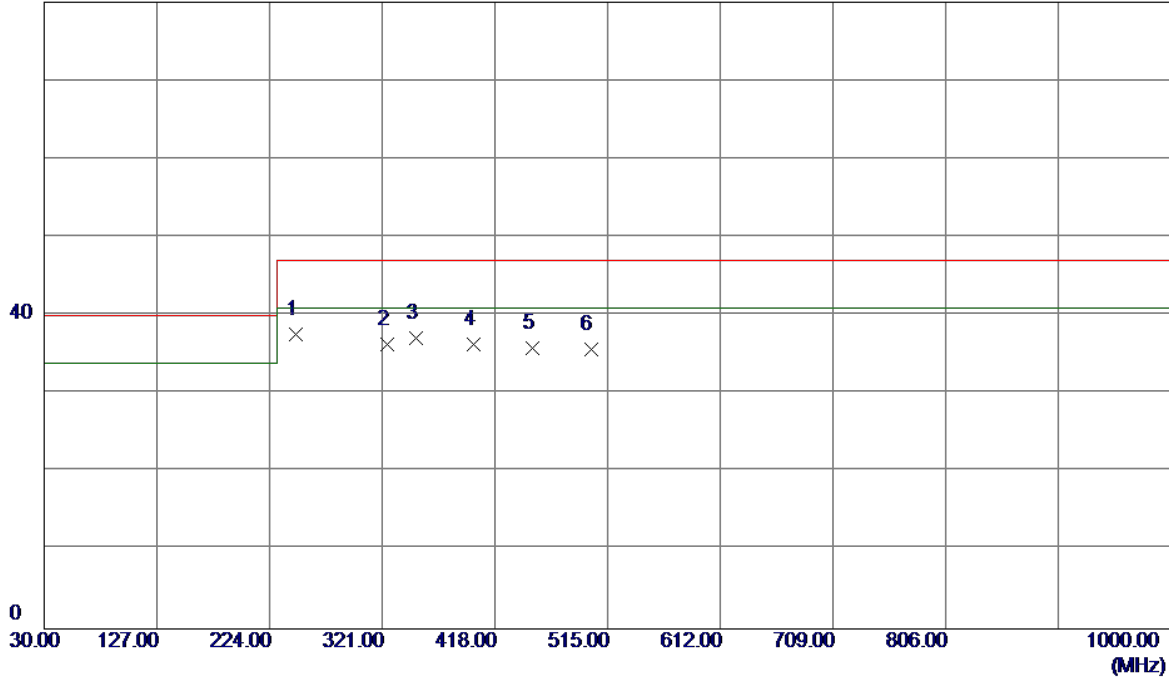

No.	Freq. MHz	Reading Level dBuV/m	Correct Factor dB	Measure ment dBuV/m	Limit dBuV/m	Margin dB	Detector
1 *	246.3100	50.91	-13.29	37.62	47.00	-9.38	QP
2	324.8800	46.40	-10.07	36.33	47.00	-10.67	QP
3	350.1000	46.64	-9.48	37.16	47.00	-9.84	QP
4	399.5700	44.61	-8.22	36.39	47.00	-10.61	QP
5	450.0100	42.90	-6.98	35.92	47.00	-11.08	QP
6	500.4500	41.46	-5.84	35.62	47.00	-11.38	QP

EUT	IP Phone	Model Name	X4
Temperature	25°C	Relative Humidity	60%
Test Voltage	AC 230V/50Hz	Polarization	Vertical
Test Mode	Handset		
Note	Adapter		
Test Engineer	Jason Yang		

80 dBuV/m

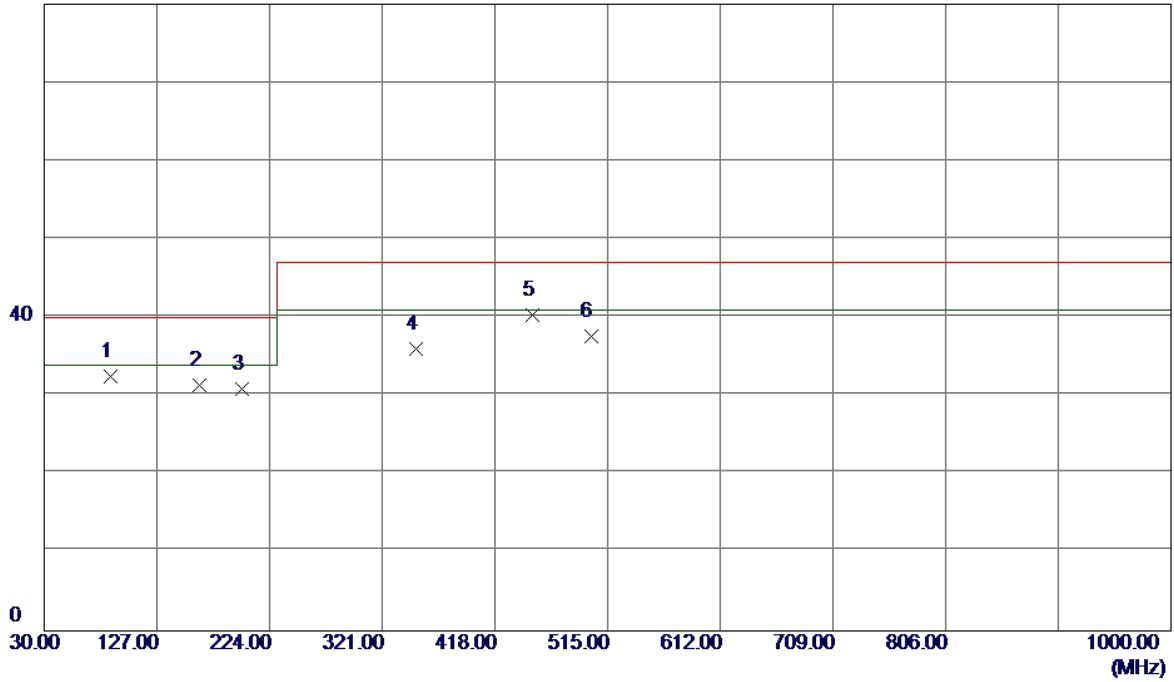

No.	Freq. MHz	Reading Level dBuV/m	Correct Factor dB	Measure ment dBuV/m	Limit dBuV/m	Margin dB	Detector
1	87.2300	49.65	-17.12	32.53	40.00	-7.47	QP
2	163.8600	42.79	-11.36	31.43	40.00	-8.57	QP
3	200.7200	43.06	-12.20	30.86	40.00	-9.14	QP
4	350.1000	45.51	-9.48	36.03	47.00	-10.97	QP
5 *	450.0100	47.37	-6.98	40.39	47.00	-6.61	QP
6	500.4500	43.37	-5.84	37.53	47.00	-9.47	QP

EUT	IP Phone	Model Name	X4
Temperature	25°C	Relative Humidity	60%
Test Voltage	AC 230V/50Hz	Polarization	Horizontal
Test Mode	Handset		
Note	Adapter		
Test Engineer	Jason Yang		

80 dBuV/m

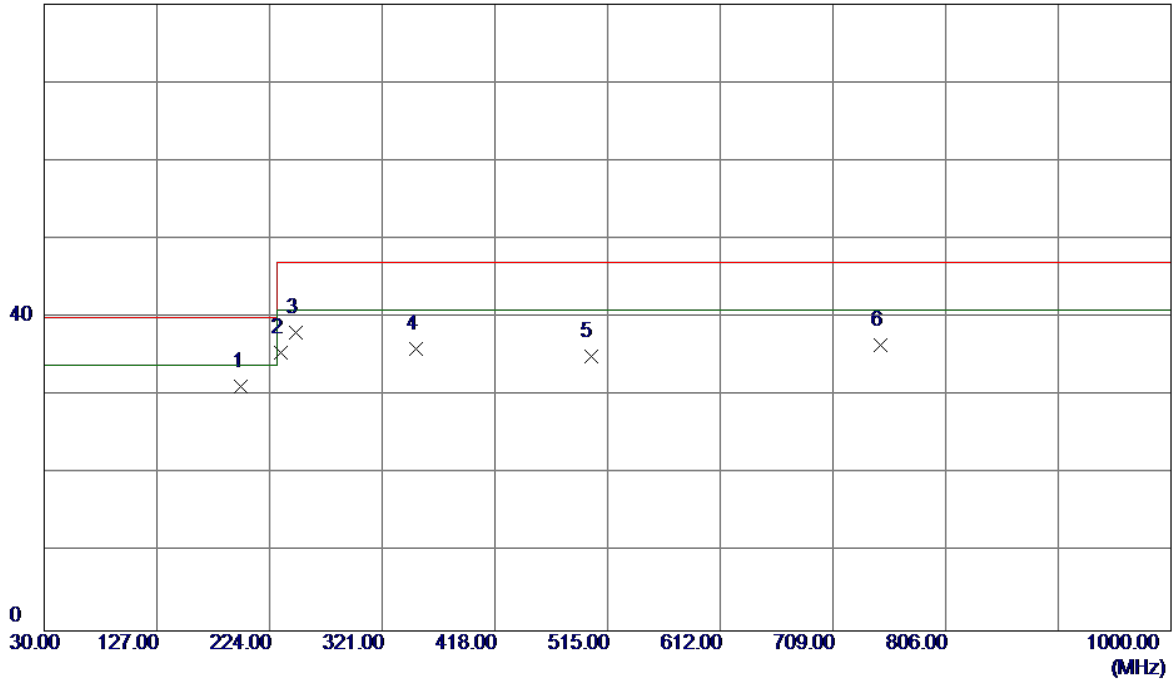

No.	Freq. MHz	Reading Level dBuV/m	Correct Factor dB	Measure ment dBuV/m	Limit dBuV/m	Margin dB	Detector
1 *	199.7500	43.37	-12.11	31.26	40.00	-8.74	QP
2	233.7000	48.87	-13.28	35.59	47.00	-11.41	QP
3	246.3100	51.35	-13.29	38.06	47.00	-8.94	QP
4	350.1000	45.51	-9.48	36.03	47.00	-10.97	QP
5	500.4500	40.87	-5.84	35.03	47.00	-11.97	QP
6	749.7400	36.66	-0.14	36.52	47.00	-10.48	QP

EUT	IP Phone	Model Name	X4
Temperature	25°C	Relative Humidity	60%
Test Voltage	DC 48V	Polarization	Vertical
Test Mode	Handset		
Note	PoE		
Test Engineer	Jason Yang		

80 dBuV/m

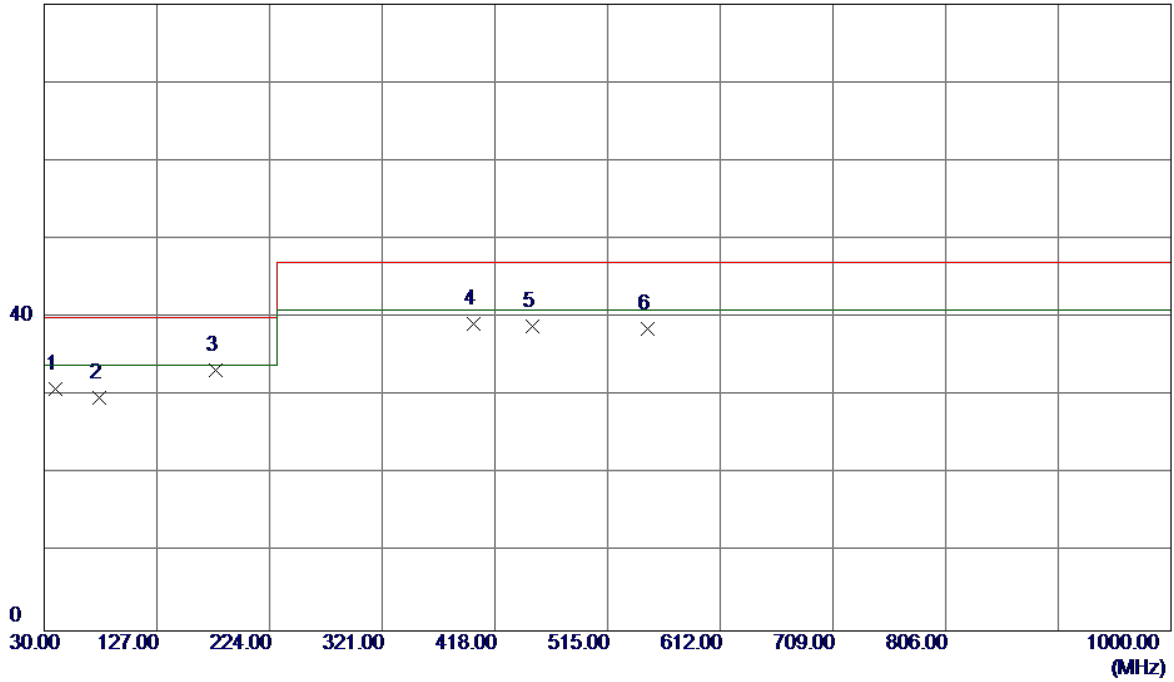

No.	Freq. MHz	Reading Level dBuV/m	Correct Factor dB	Measure ment dBuV/m	Limit dBuV/m	Margin dB	Detector
1	39.7000	43.54	-12.71	30.83	40.00	-9.17	QP
2	77.5300	45.94	-16.20	29.74	40.00	-10.26	QP
3 *	177.4400	44.64	-11.35	33.29	40.00	-6.71	QP
4	399.5700	47.47	-8.22	39.25	47.00	-7.75	QP
5	450.0100	45.86	-6.98	38.88	47.00	-8.12	QP
6	549.9200	43.04	-4.55	38.49	47.00	-8.51	QP

EUT	IP Phone	Model Name	X4
Temperature	25°C	Relative Humidity	60%
Test Voltage	DC 48V	Polarization	Horizontal
Test Mode	Handset		
Note	PoE		
Test Engineer	Jason Yang		

80 dBuV/m

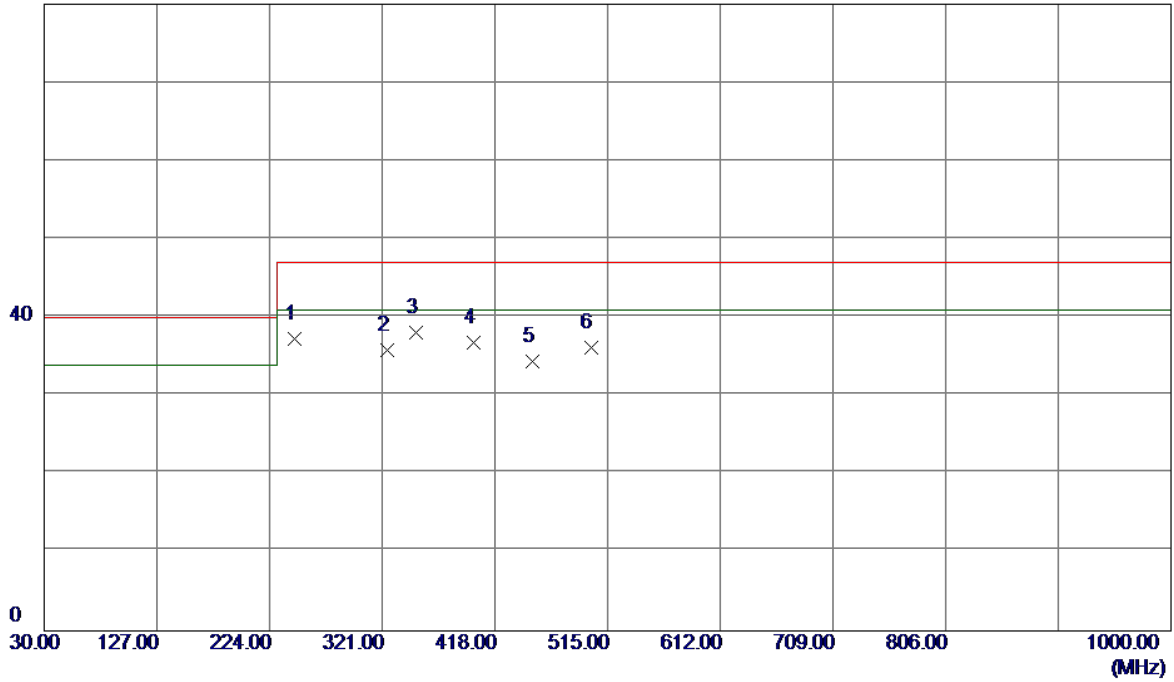

No.	Freq. MHz	Reading Level dBuV/m	Correct Factor dB	Measure ment dBuV/m	Limit dBuV/m	Margin dB	Detector
1	245.3400	50.64	-13.30	37.34	47.00	-9.66	QP
2	324.8800	45.91	-10.07	35.84	47.00	-11.16	QP
3 *	350.1000	47.49	-9.48	38.01	47.00	-8.99	QP
4	399.5700	45.06	-8.22	36.84	47.00	-10.16	QP
5	450.0100	41.45	-6.98	34.47	47.00	-12.53	QP
6	500.4500	42.02	-5.84	36.18	47.00	-10.82	QP

EUT	IP Phone	Model Name	X4
Temperature	25°C	Relative Humidity	60%
Test Voltage	AC 230V/50Hz	Polarization	Vertical
Test Mode	Earphone		
Note	Adapter		
Test Engineer	Jason Yang		

80 dBuV/m

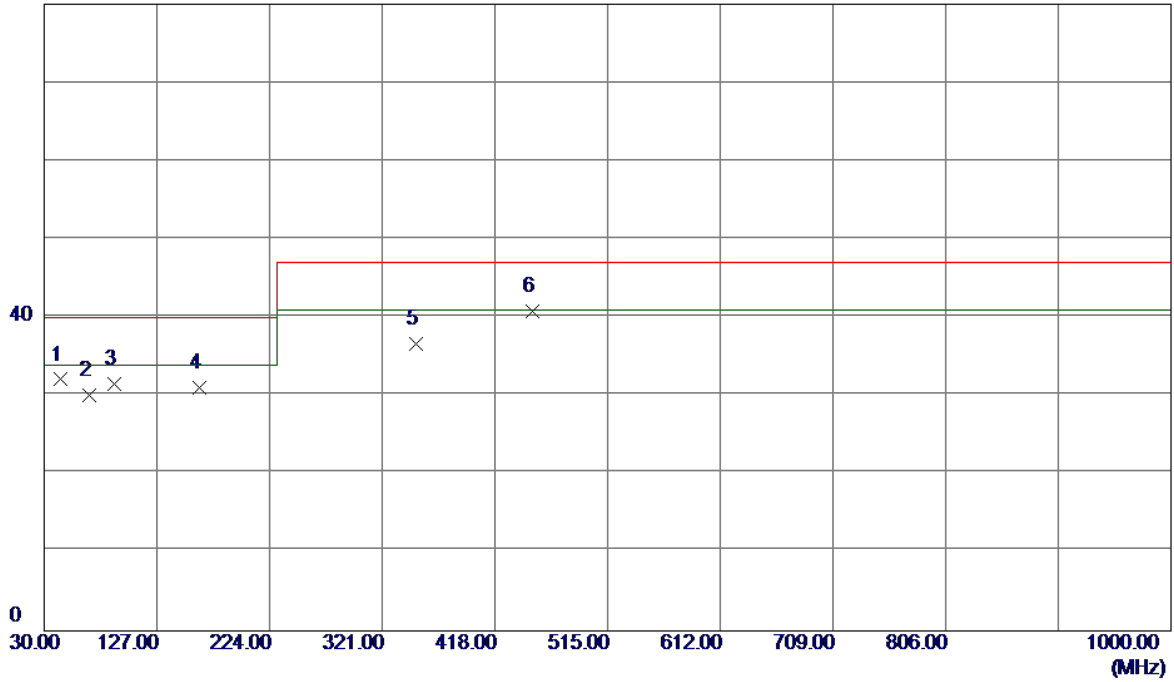

No.	Freq. MHz	Reading Level dBuV/m	Correct Factor dB	Measure ment dBuV/m	Limit dBuV/m	Margin dB	Detector
1	43.5800	44.15	-12.07	32.08	40.00	-7.92	QP
2	68.8000	44.76	-14.62	30.14	40.00	-9.86	QP
3	90.1400	48.77	-17.27	31.50	40.00	-8.50	QP
4	163.8600	42.46	-11.36	31.10	40.00	-8.90	QP
5	350.1000	46.15	-9.48	36.67	47.00	-10.33	QP
6 *	450.0100	47.82	-6.98	40.84	47.00	-6.16	QP

EUT	IP Phone	Model Name	X4
Temperature	25°C	Relative Humidity	60%
Test Voltage	AC 230V/50Hz	Polarization	Horizontal
Test Mode	Earphone		
Note	Adapter		
Test Engineer	Jason Yang		

80 dBuV/m

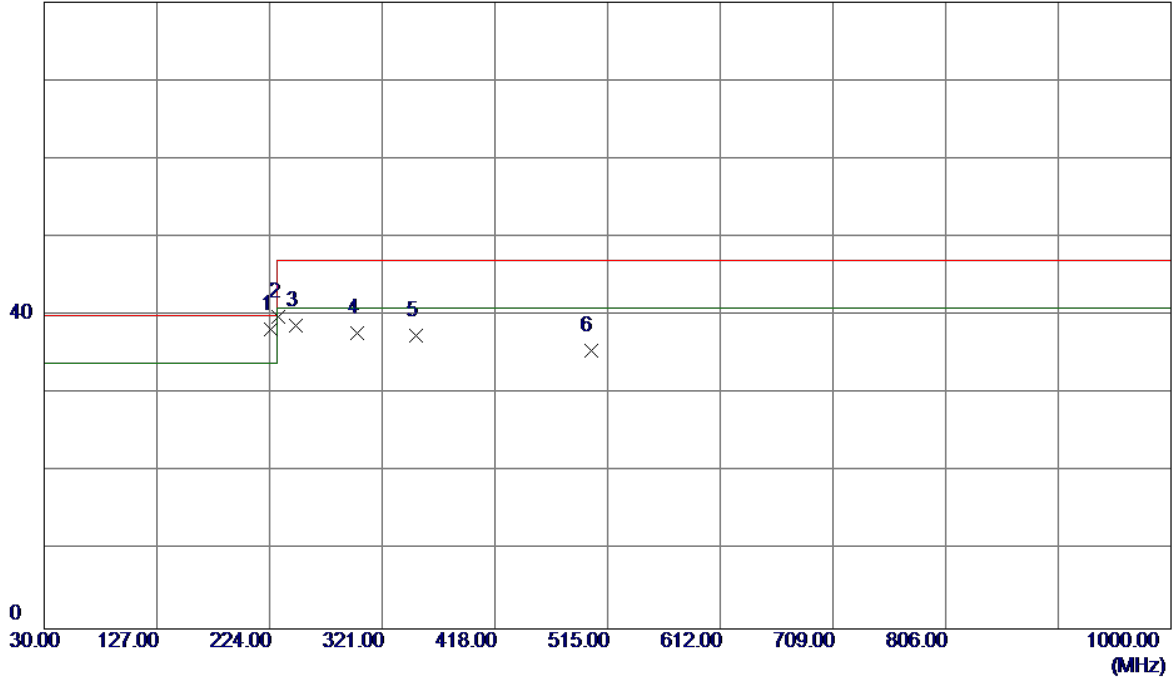

No.	Freq. MHz	Reading Level dBuV/m	Correct Factor dB	Measure ment dBuV/m	Limit dBuV/m	Margin dB	Detector
1 *	224.9700	51.66	-13.39	38.27	40.00	-1.73	QP
2	231.7600	53.07	-13.24	39.83	47.00	-7.17	QP
3	246.3100	52.00	-13.29	38.71	47.00	-8.29	QP
4	299.6600	48.42	-10.69	37.73	47.00	-9.27	QP
5	350.1000	46.98	-9.48	37.50	47.00	-9.50	QP
6	500.4500	41.29	-5.84	35.45	47.00	-11.55	QP

EUT	IP Phone	Model Name	X4
Temperature	25°C	Relative Humidity	60%
Test Voltage	DC 48V	Polarization	Vertical
Test Mode	Earphone		
Note	PoE		
Test Engineer	Jason Yang		

80 dBuV/m

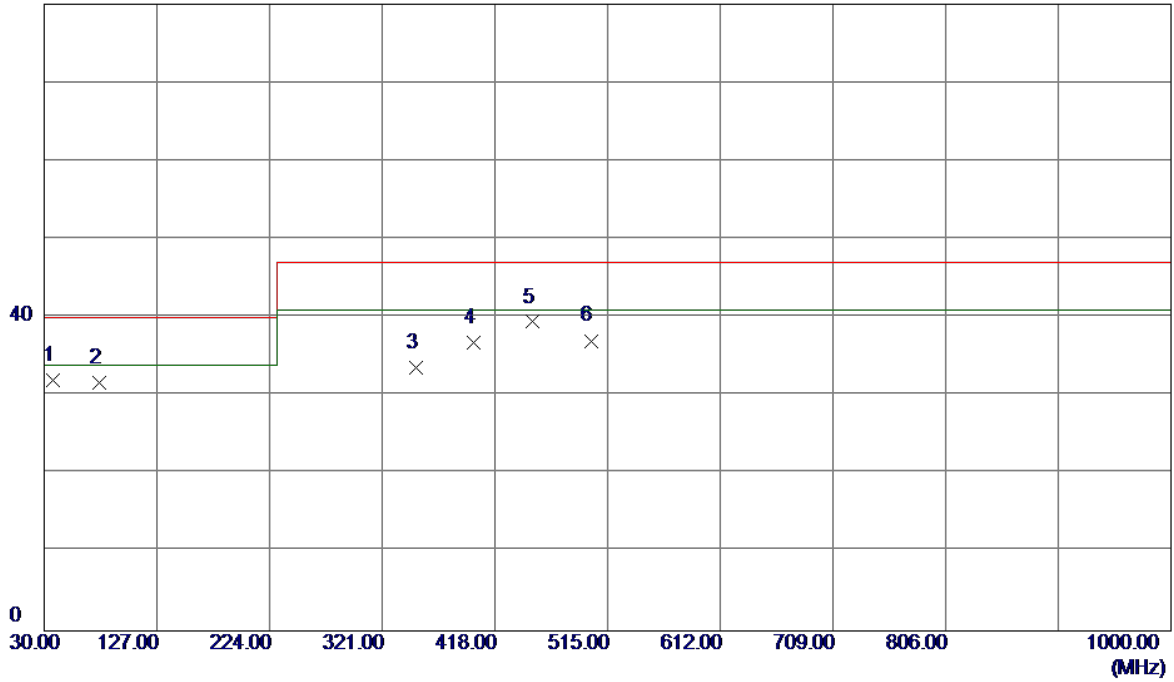

No.	Freq. MHz	Reading Level dBuV/m	Correct Factor dB	Measure ment dBuV/m	Limit dBuV/m	Margin dB	Detector
1	37.7599	44.89	-12.84	32.05	40.00	-7.95	QP
2	77.5300	47.95	-16.20	31.75	40.00	-8.25	QP
3	350.1000	43.10	-9.48	33.62	47.00	-13.38	QP
4	399.5700	45.08	-8.22	36.86	47.00	-10.14	QP
5 *	450.0100	46.42	-6.98	39.44	47.00	-7.56	QP
6	500.4500	42.88	-5.84	37.04	47.00	-9.96	QP

EUT	IP Phone	Model Name	X4
Temperature	25°C	Relative Humidity	60%
Test Voltage	DC 48V	Polarization	Horizontal
Test Mode	Earphone		
Note	PoE		
Test Engineer	Jason Yang		

80 dBuV/m

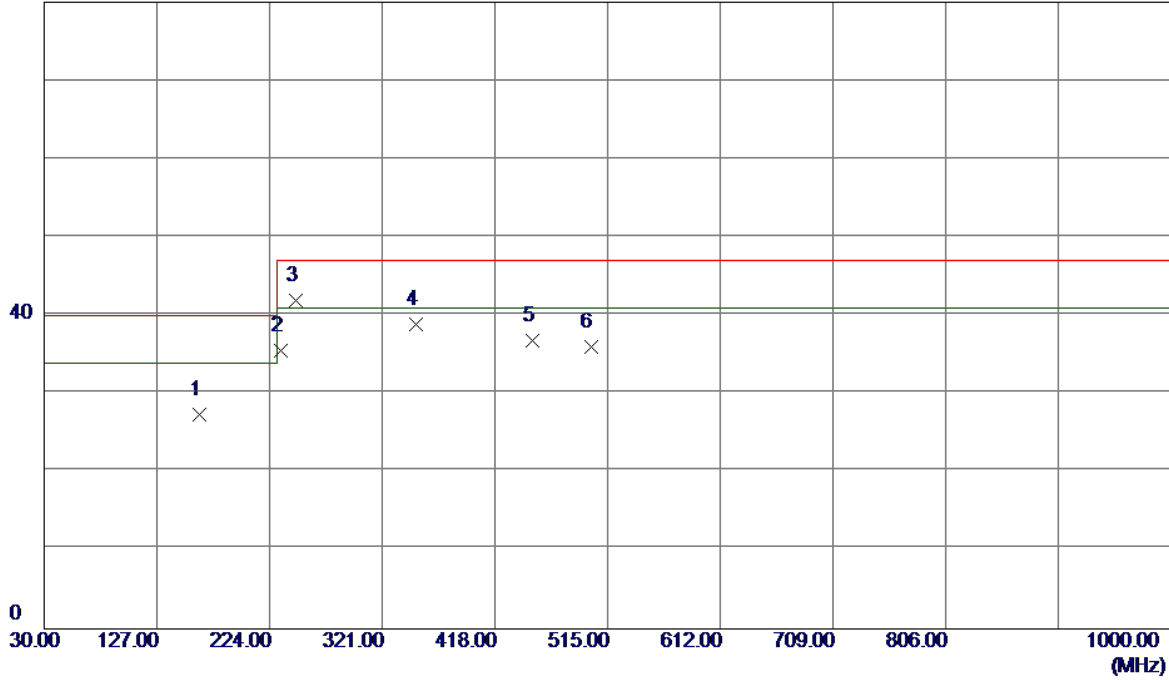

No.	Freq. MHz	Reading Level dBuV/m	Correct Factor dB	Measure ment dBuV/m	Limit dBuV/m	Margin dB	Detector
1	163.8600	38.78	-11.36	27.42	40.00	-12.58	QP
2	233.7000	48.76	-13.28	35.48	47.00	-11.52	QP
3 *	246.3100	55.17	-13.29	41.88	47.00	-5.12	QP
4	350.1000	48.37	-9.48	38.89	47.00	-8.11	QP
5	450.0100	43.79	-6.98	36.81	47.00	-10.19	QP
6	500.4500	41.84	-5.84	36.00	47.00	-11.00	QP

4.1.8 TEST RESULTS (ABOVE 1 GHZ)

EUT	IP Phone	Model Name	X4
Temperature	25°C	Relative Humidity	60%
Test Voltage	DC 48V	Polarization	Vertical
Test Mode	Handfree		
Note	PoE		
Test Engineer	Jason Yang		

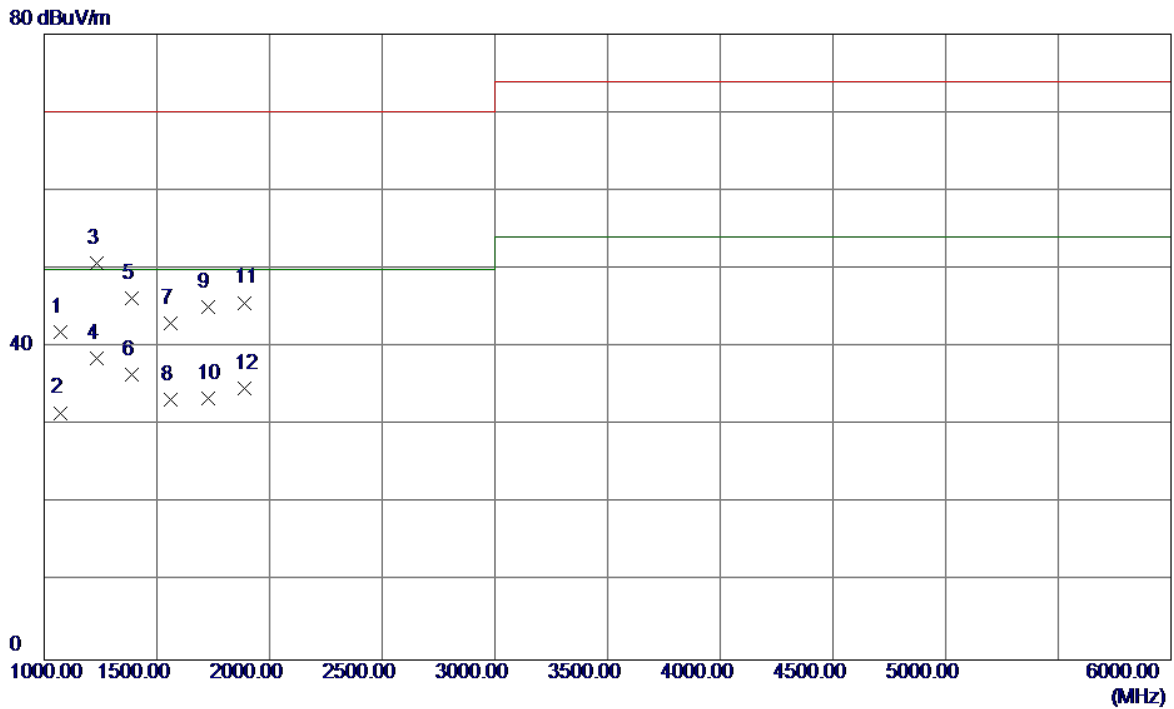

No.	Freq. MHz	Reading Level dBuV/m	Correct Factor dB	Measure ment dBuV/m	Limit dBuV/m	Margin dB	Detector
1	1070.0000	47.28	-5.33	41.95	70.00	-28.05	Peak
2	1070.0000	36.93	-5.33	31.60	50.00	-18.40	AVG
3	1235.0000	55.39	-4.66	50.73	70.00	-19.27	Peak
4 *	1235.0000	43.15	-4.66	38.49	50.00	-11.51	AVG
5	1390.0000	50.30	-4.03	46.27	70.00	-23.73	Peak
6	1390.0000	40.53	-4.03	36.50	50.00	-13.50	AVG
7	1560.0000	46.40	-3.37	43.03	70.00	-26.97	Peak
8	1560.0000	36.72	-3.37	33.35	50.00	-16.65	AVG
9	1725.0000	47.83	-2.76	45.07	70.00	-24.93	Peak
10	1725.0000	36.24	-2.76	33.48	50.00	-16.52	AVG
11	1890.0000	47.84	-2.16	45.68	70.00	-24.32	Peak
12	1890.0000	36.95	-2.16	34.79	50.00	-15.21	AVG

EUT	IP Phone	Model Name	X4
Temperature	25°C	Relative Humidity	60%
Test Voltage	DC 48V	Polarization	Horizontal
Test Mode	Handfree		
Note	PoE		
Test Engineer	Jason Yang		

80 dBuV/m

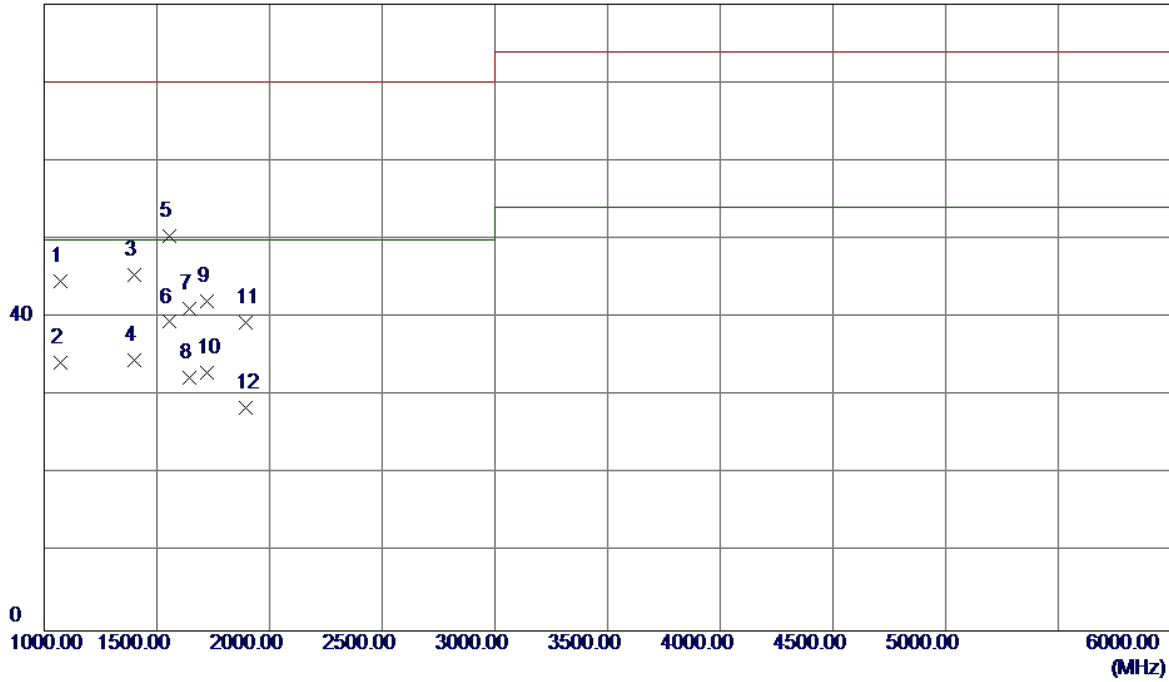

No.	Freq. MHz	Reading Level dBuV/m	Correct Factor dB	Measure ment dBuV/m	Limit dBuV/m	Margin dB	Detector
1	1070.0000	49.92	-5.33	44.59	70.00	-25.41	Peak
2	1070.0000	39.63	-5.33	34.30	50.00	-15.70	AVG
3	1400.0000	49.42	-3.99	45.43	70.00	-24.57	Peak
4	1400.0000	38.49	-3.99	34.50	50.00	-15.50	AVG
5	1555.0000	53.80	-3.38	50.42	70.00	-19.58	Peak
6 *	1555.0000	42.82	-3.38	39.44	50.00	-10.56	AVG
7	1645.0000	44.22	-3.06	41.16	70.00	-28.84	Peak
8	1645.0000	35.42	-3.06	32.36	50.00	-17.64	AVG
9	1720.0000	44.92	-2.78	42.14	70.00	-27.86	Peak
10	1720.0000	35.78	-2.78	33.00	50.00	-17.00	AVG
11	1895.0000	41.57	-2.14	39.43	70.00	-30.57	Peak
12	1895.0000	30.63	-2.14	28.49	50.00	-21.51	AVG

EUT	IP Phone	Model Name	X4
Temperature	25°C	Relative Humidity	60%
Test Voltage	AC 230V/50Hz	Polarization	Vertical
Test Mode	Handfree		
Note	Adapter		
Test Engineer	Jason Yang		

100 dBuV/m

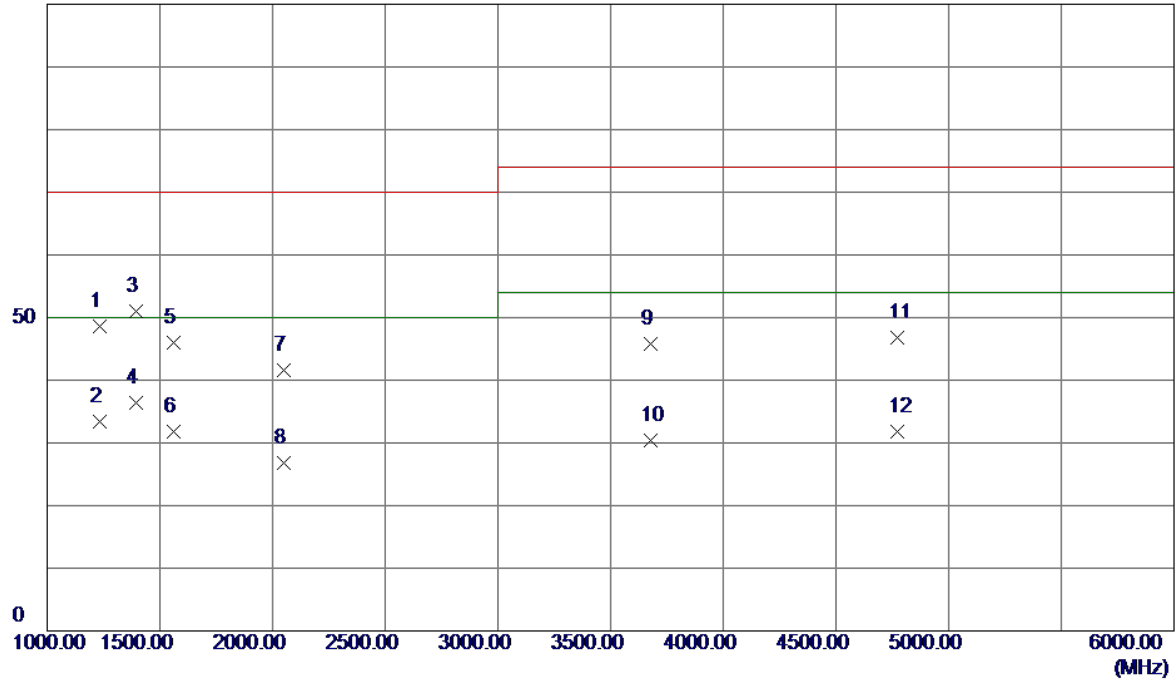

No.	Freq. MHz	Reading Level dBuV/m	Correct Factor dB	Measure ment dBuV/m	Limit dBuV/m	Margin dB	Detector
1	1232.5000	52.65	-4.08	48.57	70.00	-21.43	Peak
2	1232.5000	37.56	-4.08	33.48	50.00	-16.52	AVG
3	1395.0000	54.60	-3.55	51.05	70.00	-18.95	Peak
4 *	1395.0000	40.04	-3.55	36.49	50.00	-13.51	AVG
5	1562.5000	49.24	-3.22	46.02	70.00	-23.98	Peak
6	1562.5000	35.09	-3.22	31.87	50.00	-18.13	AVG
7	2047.5000	44.64	-3.04	41.60	70.00	-28.40	Peak
8	2047.5000	29.82	-3.04	26.78	50.00	-23.22	AVG
9	3677.5000	41.66	4.11	45.77	74.00	-28.23	Peak
10	3677.5000	26.37	4.11	30.48	54.00	-23.52	AVG
11	4775.0000	40.97	5.75	46.72	74.00	-27.28	Peak
12	4775.0000	26.12	5.75	31.87	54.00	-22.13	AVG

EUT	IP Phone	Model Name	X4
Temperature	25°C	Relative Humidity	60%
Test Voltage	AC 230V/50Hz	Polarization	Horizontal
Test Mode	Handfree		
Note	Adapter		
Test Engineer	Jason Yang		

100 dBuV/m

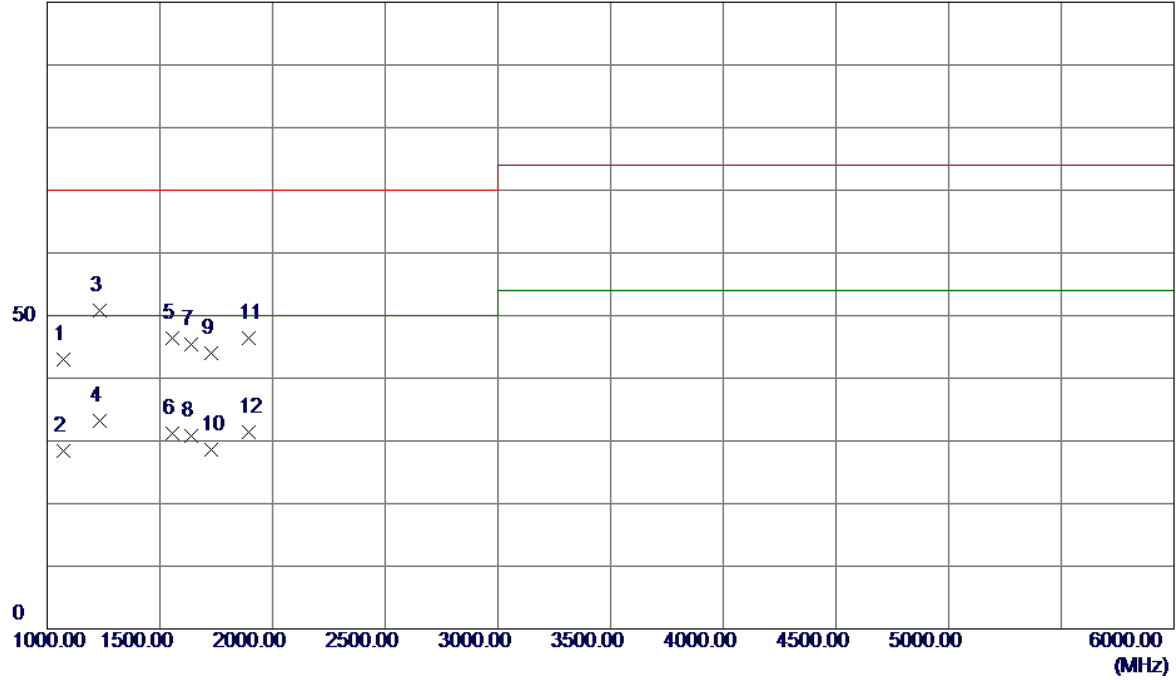

No.	Freq. MHz	Reading Level dBuV/m	Correct Factor dB	Measure ment dBuV/m	Limit dBuV/m	Margin dB	Detector
1	1070.0000	47.69	-4.62	43.07	70.00	-26.93	Peak
2	1070.0000	33.07	-4.62	28.45	50.00	-21.55	AVG
3	1235.0000	54.87	-4.07	50.80	70.00	-19.20	Peak
4 *	1235.0000	37.34	-4.07	33.27	50.00	-16.73	AVG
5	1555.0000	49.61	-3.22	46.39	70.00	-23.61	Peak
6	1555.0000	34.37	-3.22	31.15	50.00	-18.85	AVG
7	1637.5000	48.72	-3.25	45.47	70.00	-24.53	Peak
8	1637.5000	34.12	-3.25	30.87	50.00	-19.13	AVG
9	1727.5000	47.22	-3.29	43.93	70.00	-26.07	Peak
10	1727.5000	31.93	-3.29	28.64	50.00	-21.36	AVG
11	1895.0000	49.71	-3.35	46.36	70.00	-23.64	Peak
12	1895.0000	34.84	-3.35	31.49	50.00	-18.51	AVG

EUT	IP Phone	Model Name	X4
Temperature	25°C	Relative Humidity	60%
Test Voltage	DC 48V	Polarization	Vertical
Test Mode	Handset		
Note	PoE		
Test Engineer	Jason Yang		

80 dBuV/m

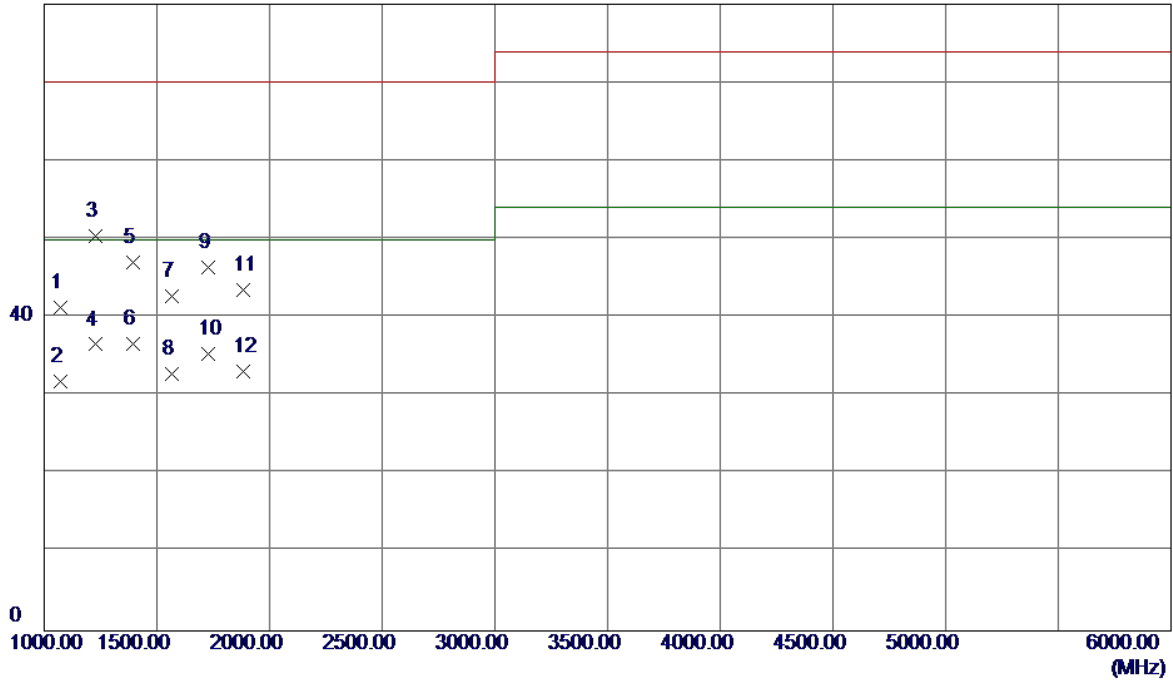

No.	Freq. MHz	Reading Level dBuV/m	Correct Factor dB	Measure ment dBuV/m	Limit dBuV/m	Margin dB	Detector
1	1070.0000	46.58	-5.33	41.25	70.00	-28.75	Peak
2	1070.0000	37.16	-5.33	31.83	50.00	-18.17	AVG
3	1230.0000	55.07	-4.68	50.39	70.00	-19.61	Peak
4	1230.0000	41.24	-4.68	36.56	50.00	-13.44	AVG
5	1395.0000	51.01	-4.01	47.00	70.00	-23.00	Peak
6 *	1395.0000	40.62	-4.01	36.61	50.00	-13.39	AVG
7	1565.0000	46.07	-3.35	42.72	70.00	-27.28	Peak
8	1565.0000	36.13	-3.35	32.78	50.00	-17.22	AVG
9	1730.0000	49.14	-2.75	46.39	70.00	-23.61	Peak
10	1730.0000	38.17	-2.75	35.42	50.00	-14.58	AVG
11	1885.0000	45.71	-2.18	43.53	70.00	-26.47	Peak
12	1885.0000	35.29	-2.18	33.11	50.00	-16.89	AVG

EUT	IP Phone	Model Name	X4
Temperature	25°C	Relative Humidity	60%
Test Voltage	DC 48V	Polarization	Horizontal
Test Mode	Handset		
Note	PoE		
Test Engineer	Jason Yang		

80 dBuV/m

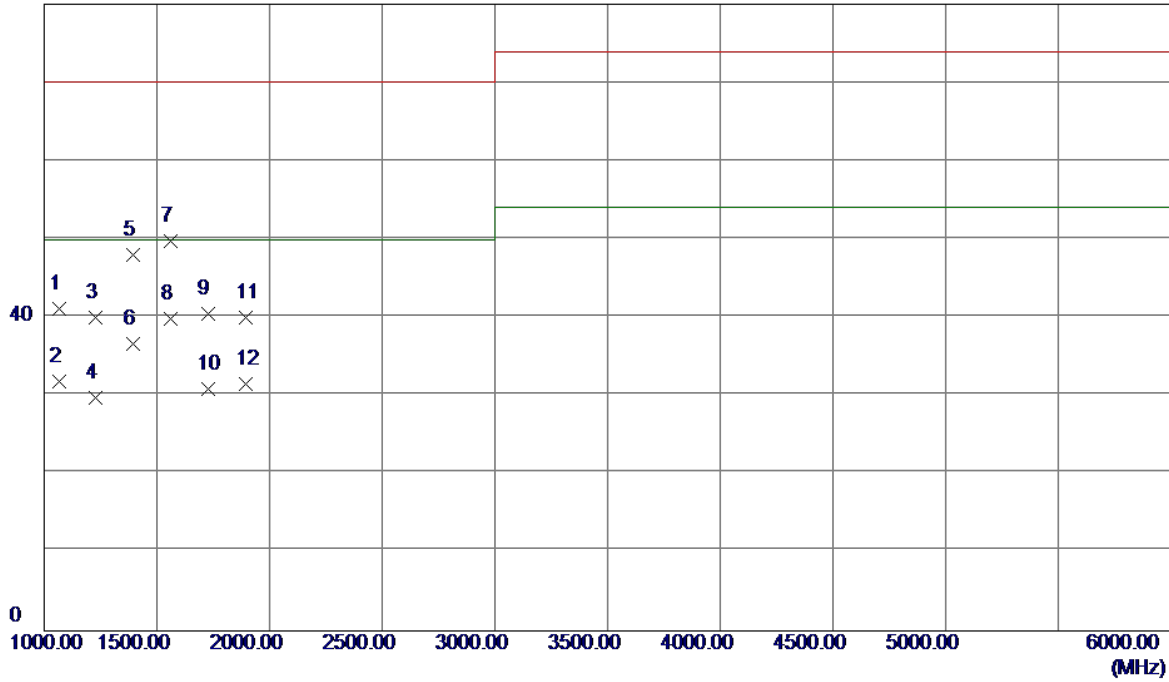

No.	Freq. MHz	Reading Level dBuV/m	Correct Factor dB	Measure ment dBuV/m	Limit dBuV/m	Margin dB	Detector
1	1065.0000	46.50	-5.35	41.15	70.00	-28.85	Peak
2	1065.0000	37.16	-5.35	31.81	50.00	-18.19	AVG
3	1230.0000	44.72	-4.68	40.04	70.00	-29.96	Peak
4	1230.0000	34.51	-4.68	29.83	50.00	-20.17	AVG
5	1395.0000	51.94	-4.01	47.93	70.00	-22.07	Peak
6	1395.0000	40.67	-4.01	36.66	50.00	-13.34	AVG
7	1560.0000	53.19	-3.37	49.82	70.00	-20.18	Peak
8 *	1560.0000	43.21	-3.37	39.84	50.00	-10.16	AVG
9	1725.0000	43.31	-2.76	40.55	70.00	-29.45	Peak
10	1725.0000	33.59	-2.76	30.83	50.00	-19.17	AVG
11	1895.0000	42.18	-2.14	40.04	70.00	-29.96	Peak
12	1895.0000	33.66	-2.14	31.52	50.00	-18.48	AVG

EUT	IP Phone	Model Name	X4
Temperature	25°C	Relative Humidity	60%
Test Voltage	AC 230V/50Hz	Polarization	Vertical
Test Mode	Handset		
Note	Adapter		
Test Engineer	Jason Yang		

100 dBuV/m

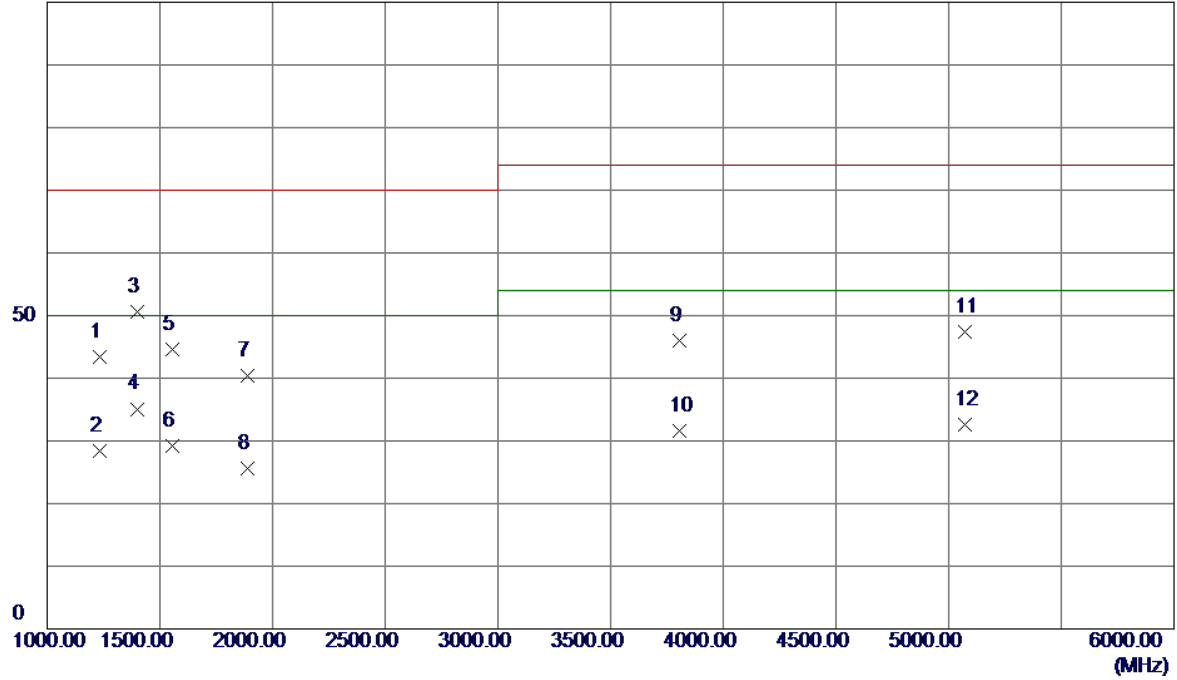

No.	Freq. MHz	Reading Level dBuV/m	Correct Factor dB	Measure ment dBuV/m	Limit dBuV/m	Margin dB	Detector
1	1235.0000	47.45	-4.07	43.38	70.00	-26.62	Peak
2	1235.0000	32.55	-4.07	28.48	50.00	-21.52	AVG
3	1397.5000	54.13	-3.54	50.59	70.00	-19.41	Peak
4 *	1397.5000	38.64	-3.54	35.10	50.00	-14.90	AVG
5	1555.0000	47.78	-3.22	44.56	70.00	-25.44	Peak
6	1555.0000	32.36	-3.22	29.14	50.00	-20.86	AVG
7	1890.0000	43.84	-3.35	40.49	70.00	-29.51	Peak
8	1890.0000	29.02	-3.35	25.67	50.00	-24.33	AVG
9	3805.0000	41.44	4.60	46.04	74.00	-27.96	Peak
10	3805.0000	27.09	4.60	31.69	54.00	-22.31	AVG
11	5072.5000	40.92	6.45	47.37	74.00	-26.63	Peak
12	5072.5000	26.13	6.45	32.58	54.00	-21.42	AVG

EUT	IP Phone	Model Name	X4
Temperature	25°C	Relative Humidity	60%
Test Voltage	AC 230V/50Hz	Polarization	Horizontal
Test Mode	Handset		
Note	Adapter		
Test Engineer	Jason Yang		

100 dBuV/m

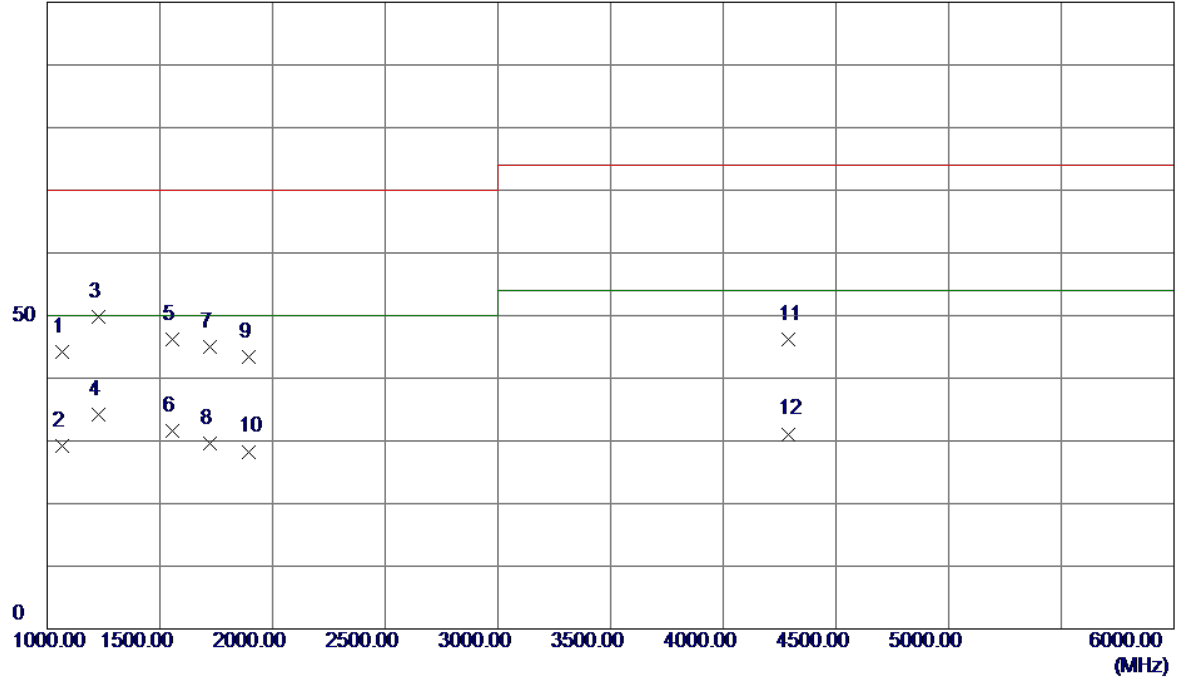

No.	Freq. MHz	Reading Level dBuV/m	Correct Factor dB	Measure ment dBuV/m	Limit dBuV/m	Margin dB	Detector
1	1067.5000	48.82	-4.63	44.19	70.00	-25.81	Peak
2	1067.5000	33.79	-4.63	29.16	50.00	-20.84	AVG
3	1230.0000	53.85	-4.09	49.76	70.00	-20.24	Peak
4 *	1230.0000	38.27	-4.09	34.18	50.00	-15.82	AVG
5	1557.5000	49.34	-3.22	46.12	70.00	-23.88	Peak
6	1557.5000	34.80	-3.22	31.58	50.00	-18.42	AVG
7	1722.5000	48.19	-3.28	44.91	70.00	-25.09	Peak
8	1722.5000	32.95	-3.28	29.67	50.00	-20.33	AVG
9	1892.5000	46.77	-3.35	43.42	70.00	-26.58	Peak
10	1892.5000	31.65	-3.35	28.30	50.00	-21.70	AVG
11	4287.5000	41.00	5.19	46.19	74.00	-27.81	Peak
12	4287.5000	25.91	5.19	31.10	54.00	-22.90	AVG

EUT	IP Phone	Model Name	X4
Temperature	25°C	Relative Humidity	60%
Test Voltage	DC 48V	Polarization	Vertical
Test Mode	Earphone		
Note	PoE		
Test Engineer	Jason Yang		

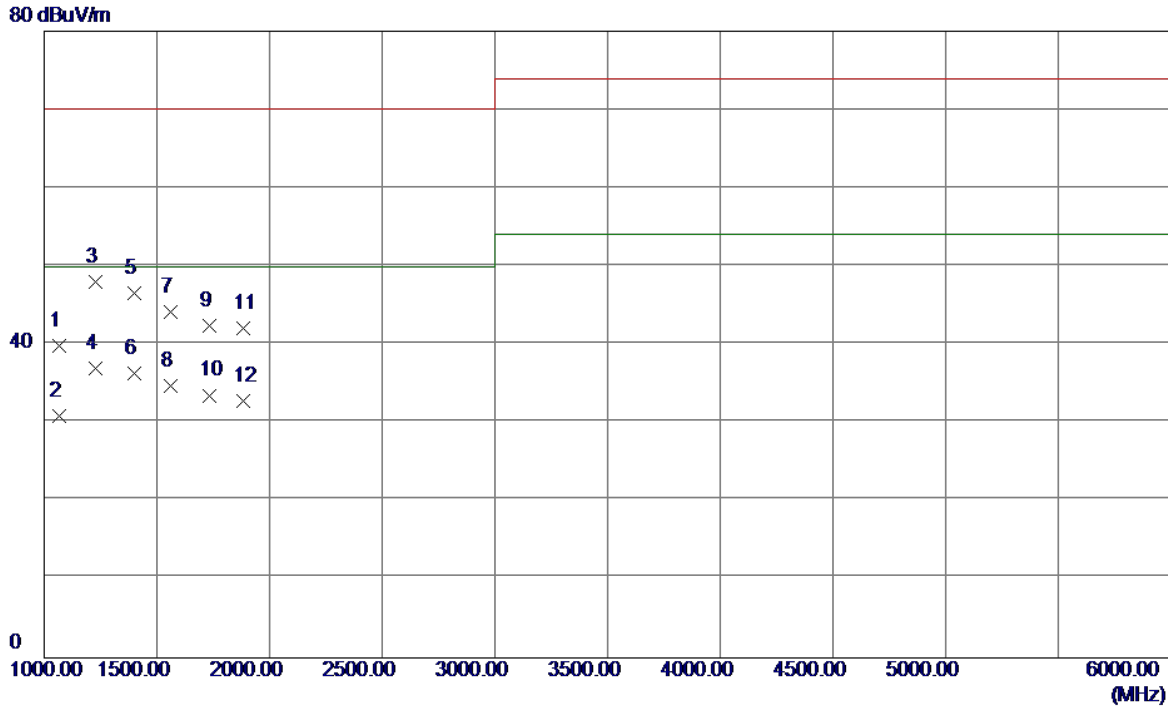

No.	Freq. MHz	Reading Level dBuV/m	Correct Factor dB	Measure ment dBuV/m	Limit dBuV/m	Margin dB	Detector
1	1065.0000	45.13	-5.35	39.78	70.00	-30.22	Peak
2	1065.0000	36.25	-5.35	30.90	50.00	-19.10	AVG
3	1230.0000	52.67	-4.68	47.99	70.00	-22.01	Peak
4 *	1230.0000	41.64	-4.68	36.96	50.00	-13.04	AVG
5	1400.0000	50.57	-3.99	46.58	70.00	-23.42	Peak
6	1400.0000	40.27	-3.99	36.28	50.00	-13.72	AVG
7	1560.0000	47.48	-3.37	44.11	70.00	-25.89	Peak
8	1560.0000	38.15	-3.37	34.78	50.00	-15.22	AVG
9	1735.0000	45.20	-2.73	42.47	70.00	-27.53	Peak
10	1735.0000	36.25	-2.73	33.52	50.00	-16.48	AVG
11	1885.0000	44.24	-2.18	42.06	70.00	-27.94	Peak
12	1885.0000	34.92	-2.18	32.74	50.00	-17.26	AVG

EUT	IP Phone	Model Name	X4
Temperature	25°C	Relative Humidity	60%
Test Voltage	DC 48V	Polarization	Horizontal
Test Mode	Earphone		
Note	PoE		
Test Engineer	Jason Yang		

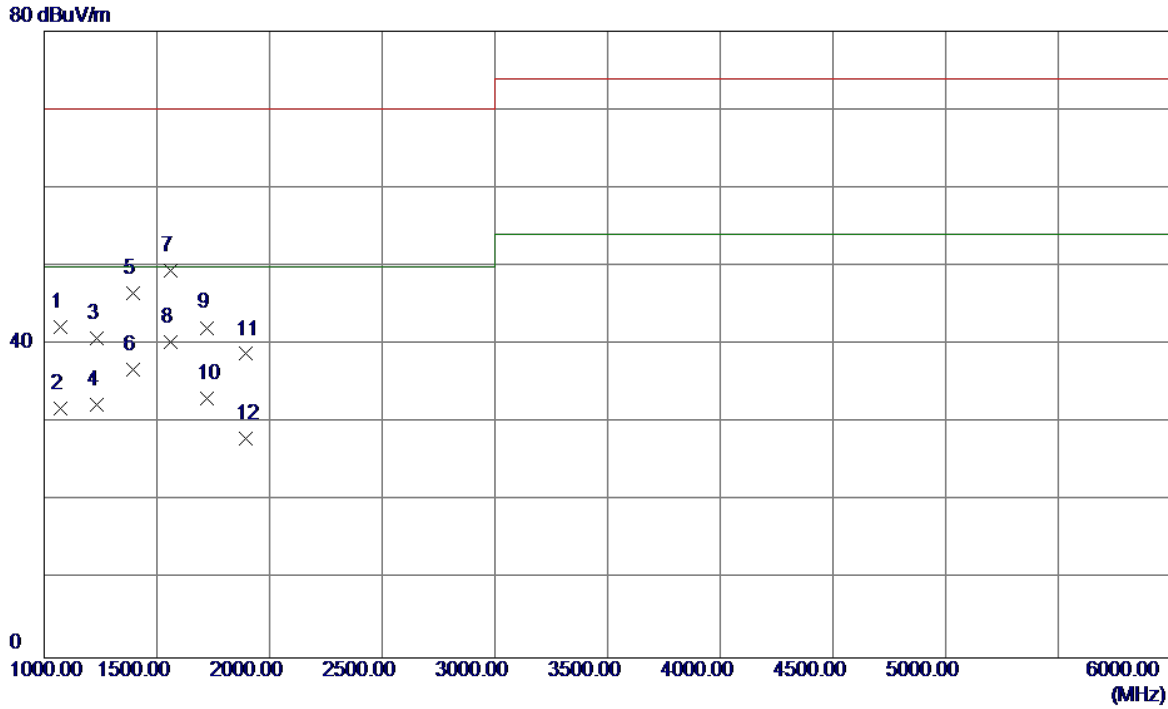

No.	Freq. MHz	Reading Level dBuV/m	Correct Factor dB	Measure ment dBuV/m	Limit dBuV/m	Margin dB	Detector
1	1070.0000	47.64	-5.33	42.31	70.00	-27.69	Peak
2	1070.0000	37.16	-5.33	31.83	50.00	-18.17	AVG
3	1235.0000	45.43	-4.66	40.77	70.00	-29.23	Peak
4	1235.0000	36.95	-4.66	32.29	50.00	-17.71	AVG
5	1395.0000	50.56	-4.01	46.55	70.00	-23.45	Peak
6	1395.0000	40.86	-4.01	36.85	50.00	-13.15	AVG
7	1560.0000	52.83	-3.37	49.46	70.00	-20.54	Peak
8 *	1560.0000	43.74	-3.37	40.37	50.00	-9.63	AVG
9	1720.0000	44.94	-2.78	42.16	70.00	-27.84	Peak
10	1720.0000	35.93	-2.78	33.15	50.00	-16.85	AVG
11	1895.0000	40.94	-2.14	38.80	70.00	-31.20	Peak
12	1895.0000	30.16	-2.14	28.02	50.00	-21.98	AVG

EUT	IP Phone	Model Name	X4
Temperature	25°C	Relative Humidity	60%
Test Voltage	AC 230V/50Hz	Polarization	Vertical
Test Mode	Earphone		
Note	Adapter		
Test Engineer	Jason Yang		

100 dBuV/m

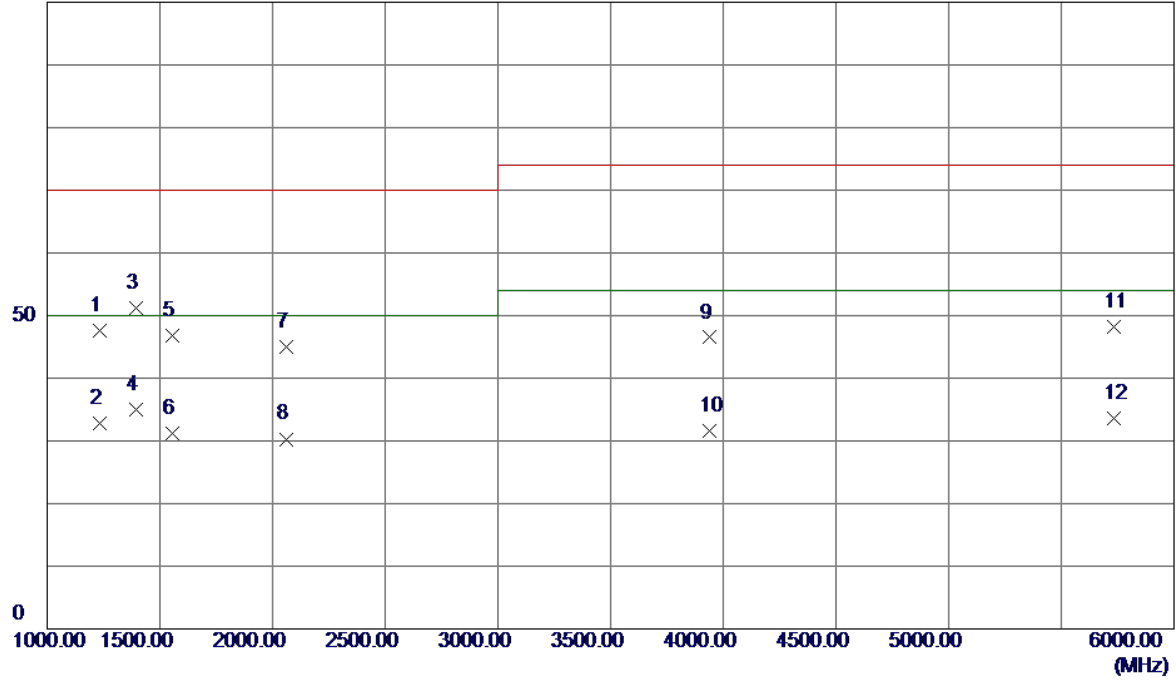

No.	Freq. MHz	Reading Level dBuV/m	Correct Factor dB	Measurement dBuV/m	Limit dBuV/m	Margin dB	Detector
1	1235.0000	51.75	-4.07	47.68	70.00	-22.32	Peak
2	1235.0000	36.94	-4.07	32.87	50.00	-17.13	AVG
3	1395.0000	54.69	-3.55	51.14	70.00	-18.86	Peak
4 *	1395.0000	38.47	-3.55	34.92	50.00	-15.08	AVG
5	1557.5000	49.99	-3.22	46.77	70.00	-23.23	Peak
6	1557.5000	34.41	-3.22	31.19	50.00	-18.81	AVG
7	2060.0000	47.95	-2.95	45.00	70.00	-25.00	Peak
8	2060.0000	33.25	-2.95	30.30	50.00	-19.70	AVG
9	3940.0000	41.39	5.11	46.50	74.00	-27.50	Peak
10	3940.0000	26.56	5.11	31.67	54.00	-22.33	AVG
11	5735.0000	40.84	7.42	48.26	74.00	-25.74	Peak
12	5735.0000	26.25	7.42	33.67	54.00	-20.33	AVG

EUT	IP Phone	Model Name	X4
Temperature	25°C	Relative Humidity	60%
Test Voltage	AC 230V/50Hz	Polarization	Horizontal
Test Mode	Earphone		
Note	Adapter		
Test Engineer	Jason Yang		

100 dBuV/m

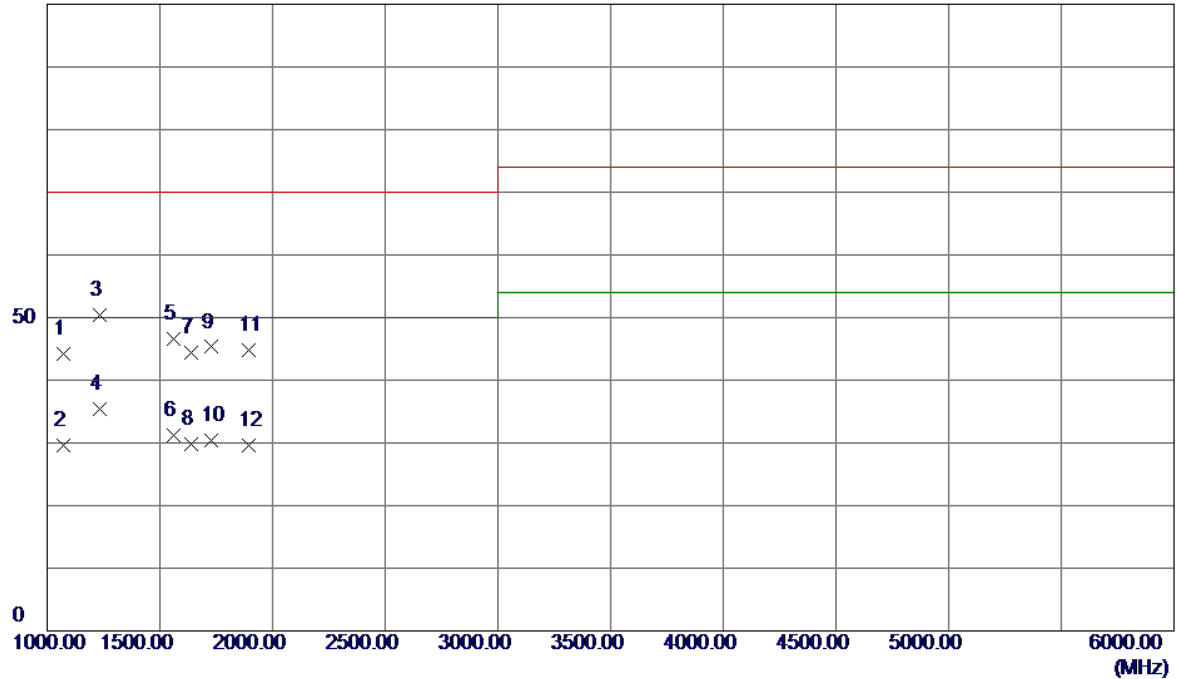

No.	Freq. MHz	Reading Level dBuV/m	Correct Factor dB	Measure ment dBuV/m	Limit dBuV/m	Margin dB	Detector
1	1070.0000	48.90	-4.62	44.28	70.00	-25.72	Peak
2	1070.0000	34.29	-4.62	29.67	50.00	-20.33	AVG
3	1232.5000	54.46	-4.08	50.38	70.00	-19.62	Peak
4 *	1232.5000	39.56	-4.08	35.48	50.00	-14.52	AVG
5	1562.5000	49.80	-3.22	46.58	70.00	-23.42	Peak
6	1562.5000	34.38	-3.22	31.16	50.00	-18.84	AVG
7	1640.0000	47.64	-3.25	44.39	70.00	-25.61	Peak
8	1640.0000	33.03	-3.25	29.78	50.00	-20.22	AVG
9	1727.5000	48.59	-3.29	45.30	70.00	-24.70	Peak
10	1727.5000	33.78	-3.29	30.49	50.00	-19.51	AVG
11	1895.0000	48.09	-3.35	44.74	70.00	-25.26	Peak
12	1895.0000	32.96	-3.35	29.61	50.00	-20.39	AVG

4.2 CONDUCTED EMISSION MEASUREMENT AT AC MAINS POWER PORTS

4.2.1 LIMITS

Requirements for conducted emissions from AC mains power ports of Class A equipment

Table clause	Frequency Range MHz	Coupling Device	Detector Type / bandwidth	Class A Limits (dB(μV))
A9.1	0.15 - 0.5	AMN	Quasi Peak / 9 kHz	79
	0.5 - 30			73
A9.2	0.15 - 0.5	AMN	Average / 9 kHz	66
	0.5 - 30			60

Apply A9.1 and A9.2 across the entire frequency range.

Requirements for conducted emissions from AC mains power ports of Class B equipment

Table clause	Frequency Range MHz	Coupling Device	Detector Type / bandwidth	Class B Limits (dB(μV))
A10.1	0.15 - 0.5	AMN	Quasi Peak / 9 kHz	66-56
	0.5 - 5			56
	5 - 30			60
A10.2	0.15 - 0.5	AMN	Average / 9 kHz	56-46
	0.5 - 5			46
	5 - 30			50

Apply A10.1 and A10.2 across the entire frequency range.

NOTE:

- (1) The test result calculated as following:
 Measurement Value = Reading Level + Correct Factor
 Correct Factor = Insertion Loss + Cable Loss + Attenuator Factor(if use)
 Margin Level = Measurement Value – Limit Value

4.2.2 MEASUREMENT INSTRUMENTS LIST

Item	Kind of Equipment	Manufacturer	Type No.	Serial No.	Calibrated until
1	Measurement Software	Farad	EZ-EMC Ver.NB-03A 1-01	N/A	N/A
2	50Ω Terminator	SHX	TF2-3G-A	08122901	Mar. 26, 2018
3	TWO-LINE V-NETWORK	R&S	ENV216	100526	Mar. 26, 2018
4	EMI Test Receiver	R&S	ESR3	101862	Sep. 04, 2017
5	Artificial-Mains Network	SCHWARZBECK	NSLK 8127	8127685	Sep. 04, 2017
6	Cable	N/A	RG400 12m	N/A	Mar. 07, 2018

Remark: "N/A" denotes no model name, no serial no. or no calibration specified.
 All calibration period of equipment list is one year.

4.2.3 TEST PROCEDURE

- The EUT was placed 0.8 meters from the horizontal ground plane with EUT being connected to the power mains through a line impedance stabilization network (LISN). All other support equipments powered from additional LISN(s). The LISN provide 50 Ohm/ 50uH of coupling impedance for the measuring instrument.
- Interconnecting cables that hang closer than 40 cm to the ground plane shall be folded back and forth in the center forming a bundle 30 to 40 cm long.
- I/O cables that are not connected to a peripheral shall be bundled in the center. The end of the cable may be terminated, if required, using the correct terminating impedance. The overall length shall not exceed 1 m.
- LISN at least 80 cm from nearest part of EUT chassis.
- For the actual test configuration, please refer to the related Item –EUT Test Photos.

4.2.4 DEVIATION FROM TEST STANDARD

No deviation

4.2.5 TEST SETUP

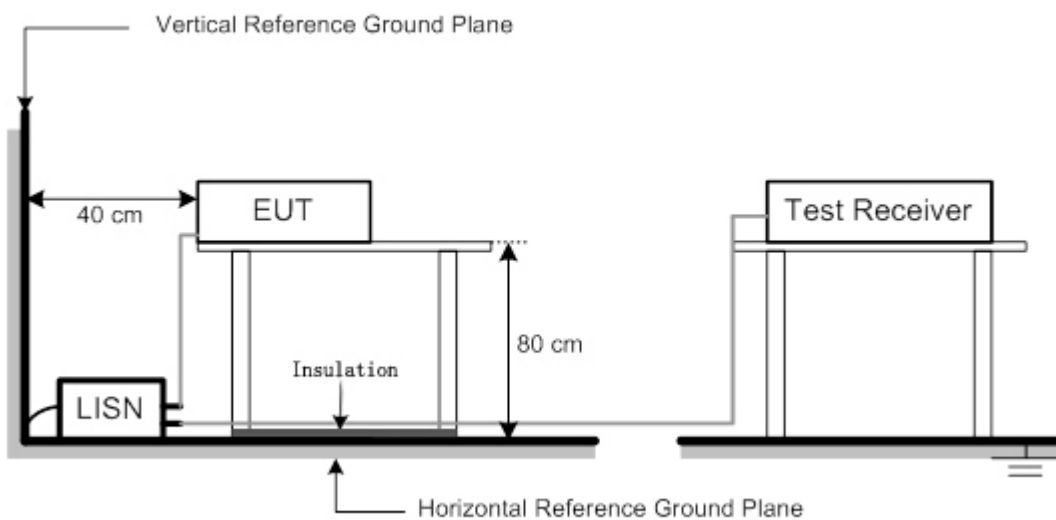

4.2.6 TEST RESULTS

EUT	IP Phone	Model Name	X4
Temperature	24°C	Relative Humidity	60%
Test Voltage	AC 230V/50Hz	Phase	Line
Test Mode	Handfree		
Note	Adapter		
Test Engineer	Jason Yang		

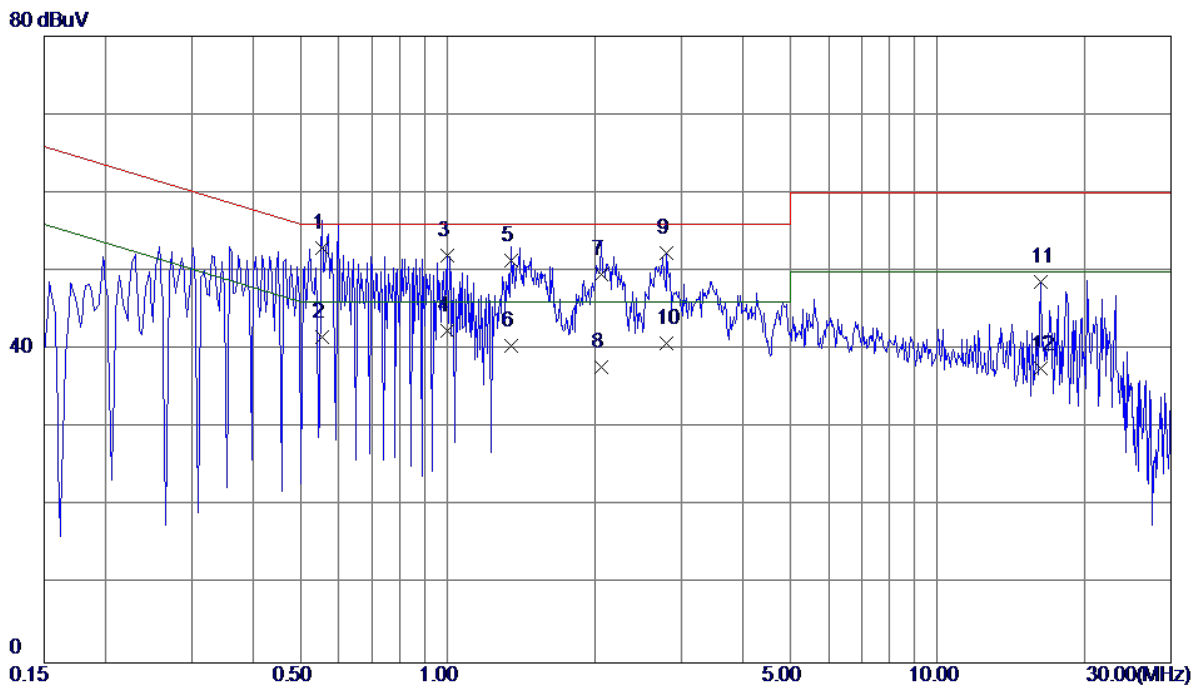

No.	Freq. MHz	Reading Level dBuV	Correct Factor dB	Measure ment dBuV	Limit dBuV	Margin dB	Detector
1 *	0.5540	43.30	9.70	53.00	56.00	-3.00	QP
2	0.5540	31.90	9.70	41.60	46.00	-4.40	AVG
3	0.9980	42.15	9.84	51.99	56.00	-4.01	QP
4	0.9980	32.60	9.84	42.44	46.00	-3.56	AVG
5	1.3500	41.50	9.91	51.41	56.00	-4.59	QP
6	1.3500	30.50	9.91	40.41	46.00	-5.59	AVG
7	2.0579	39.49	10.04	49.53	56.00	-6.47	QP
8	2.0579	27.69	10.04	37.73	46.00	-8.27	AVG
9	2.7980	42.00	10.25	52.25	56.00	-3.75	QP
10	2.7980	30.50	10.25	40.75	46.00	-5.25	AVG
11	16.2300	37.94	10.72	48.66	60.00	-11.34	QP
12	16.2300	26.80	10.72	37.52	50.00	-12.48	AVG

EUT	IP Phone	Model Name	X4
Temperature	24°C	Relative Humidity	60%
Test Voltage	AC 230V/50Hz	Phase	Neutral
Test Mode	Handfree		
Note	Adapter		
Test Engineer	Jason Yang		

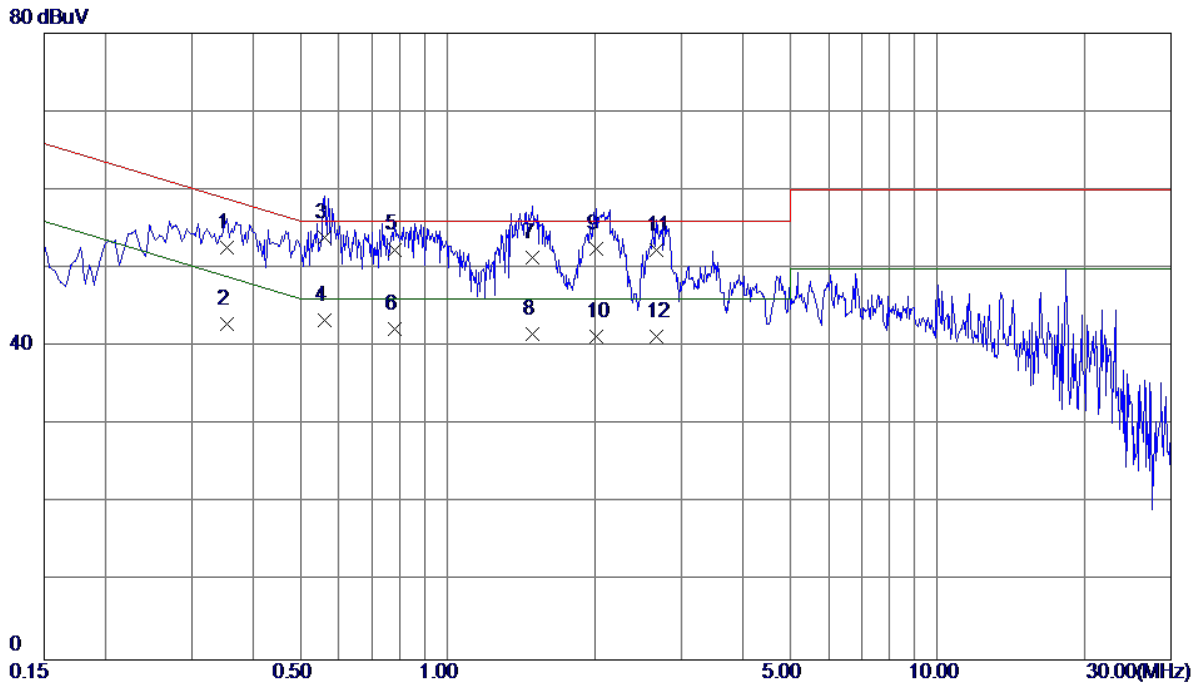

No.	Freq. MHz	Reading Level dBuV	Correct Factor dB	Measure ment dBuV	Limit dBuV	Margin dB	Detector
1	0.3540	43.10	9.57	52.67	58.87	-6.20	QP
2	0.3540	33.30	9.57	42.87	48.87	-6.00	AVG
3 *	0.5620	44.35	9.50	53.85	56.00	-2.15	QP
4	0.5620	33.81	9.50	43.31	46.00	-2.69	AVG
5	0.7820	42.80	9.60	52.40	56.00	-3.60	QP
6	0.7820	32.70	9.60	42.30	46.00	-3.70	AVG
7	1.4940	41.60	9.77	51.37	56.00	-4.63	QP
8	1.4940	31.80	9.77	41.57	46.00	-4.43	AVG
9	2.0140	42.60	9.81	52.41	56.00	-3.59	QP
10	2.0140	31.50	9.81	41.31	46.00	-4.69	AVG
11	2.6740	42.36	9.94	52.30	56.00	-3.70	QP
12	2.6740	31.40	9.94	41.34	46.00	-4.66	AVG

EUT	IP Phone	Model Name	X4
Temperature	24°C	Relative Humidity	60%
Test Voltage	AC 230V/50Hz	Phase	Line
Test Mode	Handset		
Note	Adapter		
Test Engineer	Jason Yang		

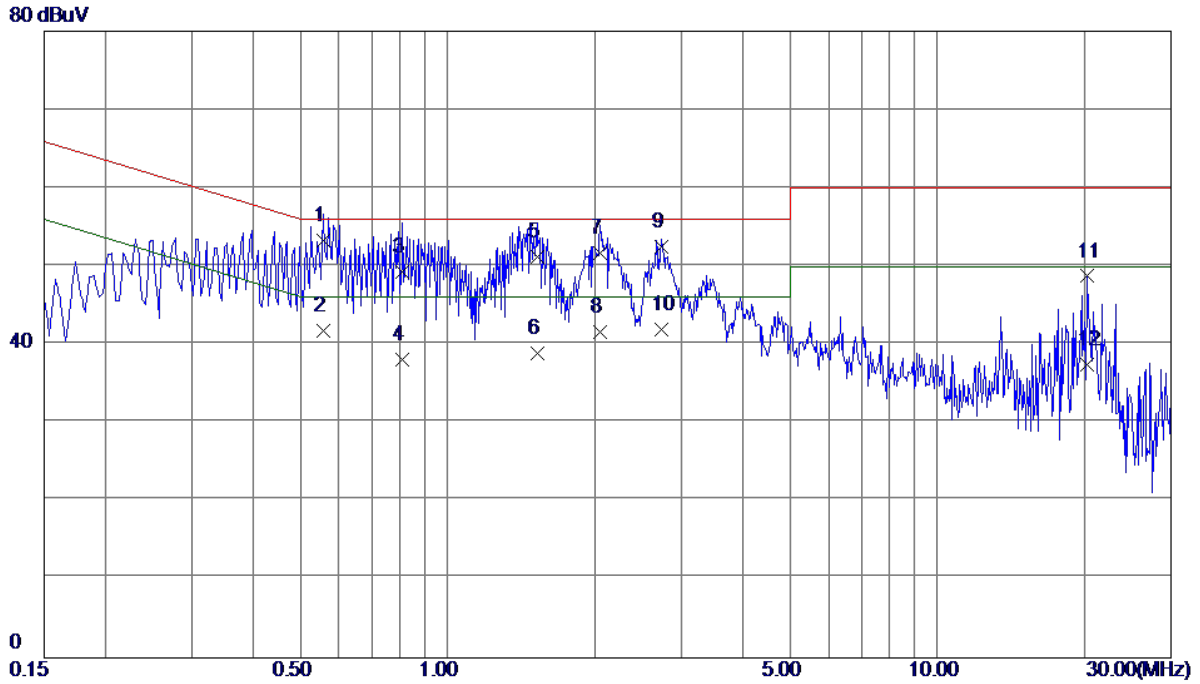

No.	Freq. MHz	Reading Level dBuV	Correct Factor dB	Measure ment dBuV	Limit dBuV	Margin dB	Detector
1 *	0.5580	43.60	9.70	53.30	56.00	-2.70	QP
2	0.5580	32.10	9.70	41.80	46.00	-4.20	AVG
3	0.8100	39.50	9.82	49.32	56.00	-6.68	QP
4	0.8100	28.30	9.82	38.12	46.00	-7.88	AVG
5	1.5260	41.20	9.98	51.18	56.00	-4.82	QP
6	1.5260	28.90	9.98	38.88	46.00	-7.12	AVG
7	2.0500	41.60	10.03	51.63	56.00	-4.37	QP
8	2.0500	31.50	10.03	41.53	46.00	-4.47	AVG
9	2.7300	42.30	10.25	52.55	56.00	-3.45	QP
10	2.7300	31.70	10.25	41.95	46.00	-4.05	AVG
11	20.2580	37.92	10.80	48.72	60.00	-11.28	QP
12	20.2580	26.70	10.80	37.50	50.00	-12.50	AVG

EUT	IP Phone	Model Name	X4
Temperature	24°C	Relative Humidity	60%
Test Voltage	AC 230V/50Hz	Phase	Neutral
Test Mode	Handset		
Note	Adapter		
Test Engineer	Jason Yang		

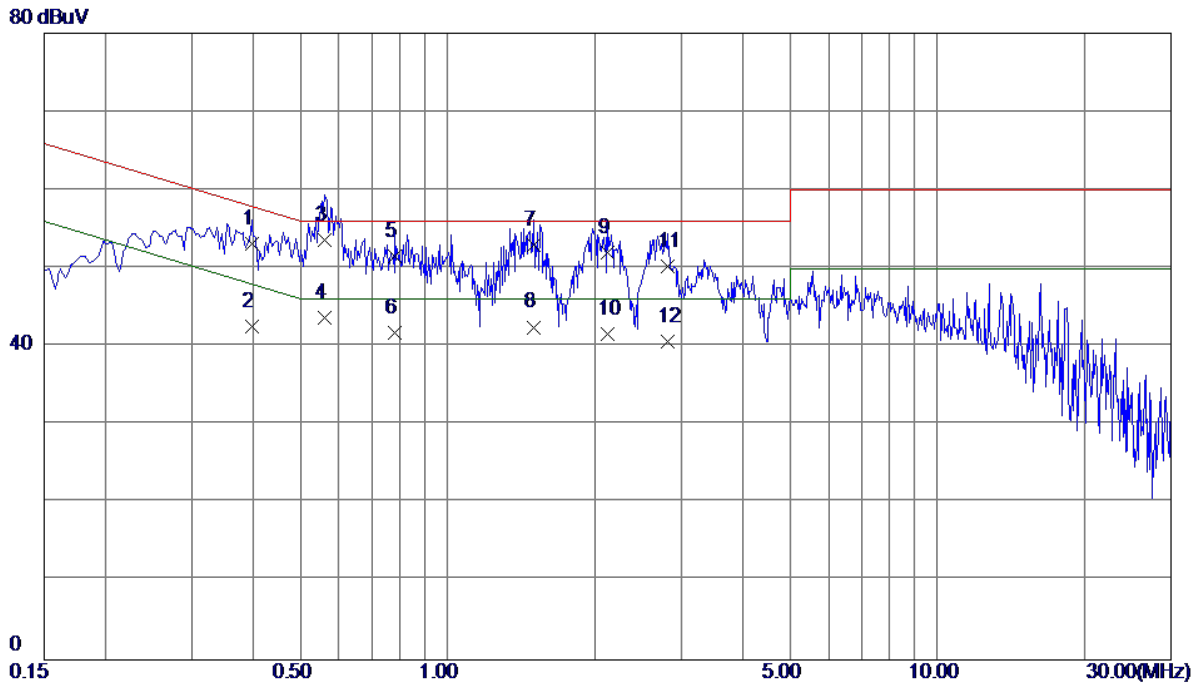

No.	Freq. MHz	Reading Level dBuV	Correct Factor dB	Measure ment dBuV	Limit dBuV	Margin dB	Detector
1	0.3980	43.59	9.49	53.08	57.90	-4.82	QP
2	0.3980	33.09	9.49	42.58	47.90	-5.32	AVG
3	0.5620	44.12	9.50	53.62	56.00	-2.38	QP
4 *	0.5620	34.26	9.50	43.76	46.00	-2.24	AVG
5	0.7820	41.90	9.60	51.50	56.00	-4.50	QP
6	0.7820	32.10	9.60	41.70	46.00	-4.30	AVG
7	1.5020	43.11	9.77	52.88	56.00	-3.12	QP
8	1.5020	32.71	9.77	42.48	46.00	-3.52	AVG
9	2.1220	42.10	9.84	51.94	56.00	-4.06	QP
10	2.1220	31.80	9.84	41.64	46.00	-4.36	AVG
11	2.8060	40.30	9.95	50.25	56.00	-5.75	QP
12	2.8060	30.70	9.95	40.65	46.00	-5.35	AVG

EUT	IP Phone	Model Name	X4
Temperature	24°C	Relative Humidity	60%
Test Voltage	AC 230V/50Hz	Phase	Line
Test Mode	Earphone		
Note	Adapter		
Test Engineer	Jason Yang		

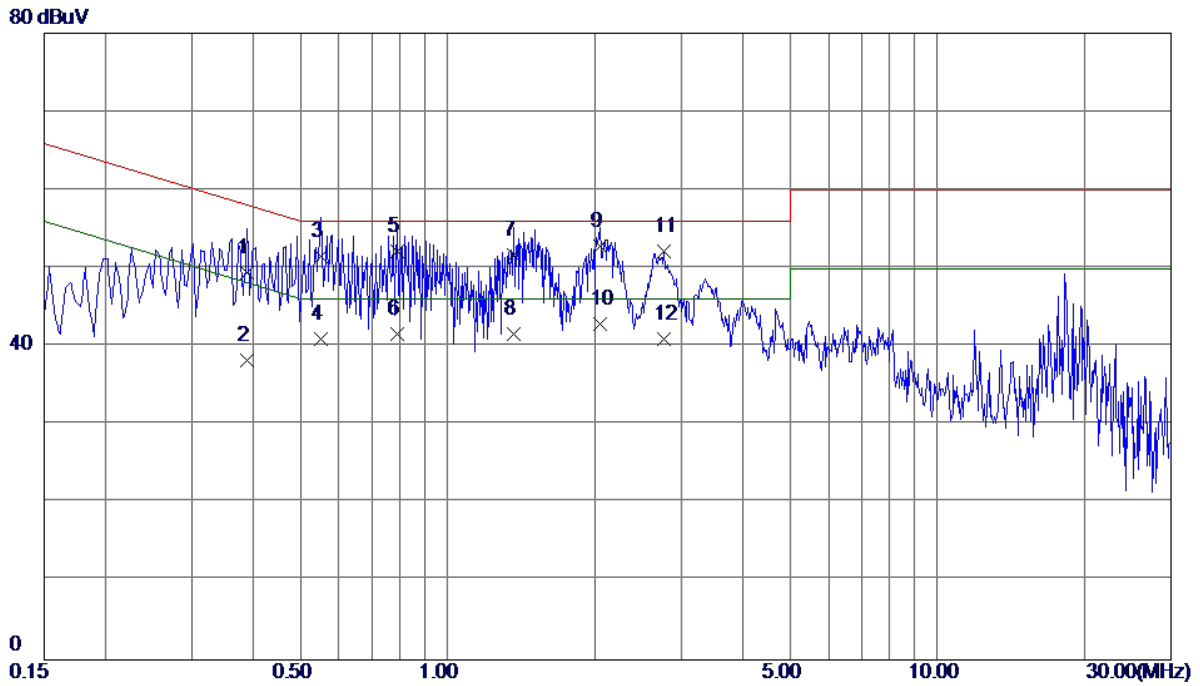

No.	Freq. MHz	Reading Level dBuV	Correct Factor dB	Measure ment dBuV	Limit dBuV	Margin dB	Detector
1	0.3899	39.90	9.58	49.48	58.07	-8.59	QP
2	0.3899	28.60	9.58	38.18	48.07	-9.89	AVG
3	0.5500	41.81	9.69	51.50	56.00	-4.50	QP
4	0.5500	31.21	9.69	40.90	46.00	-5.10	AVG
5	0.7900	42.30	9.81	52.11	56.00	-3.89	QP
6	0.7900	31.80	9.81	41.61	46.00	-4.39	AVG
7	1.3660	41.81	9.92	51.73	56.00	-4.27	QP
8	1.3660	31.61	9.92	41.53	46.00	-4.47	AVG
9	2.0420	42.70	10.03	52.73	56.00	-3.27	QP
10 *	2.0420	32.80	10.03	42.83	46.00	-3.17	AVG
11	2.7659	41.93	10.25	52.18	56.00	-3.82	QP
12	2.7659	30.70	10.25	40.95	46.00	-5.05	AVG

EUT	IP Phone	Model Name	X4
Temperature	24°C	Relative Humidity	60%
Test Voltage	AC 230V/50Hz	Phase	Neutral
Test Mode	Earphone		
Note	Adapter		
Test Engineer	Jason Yang		

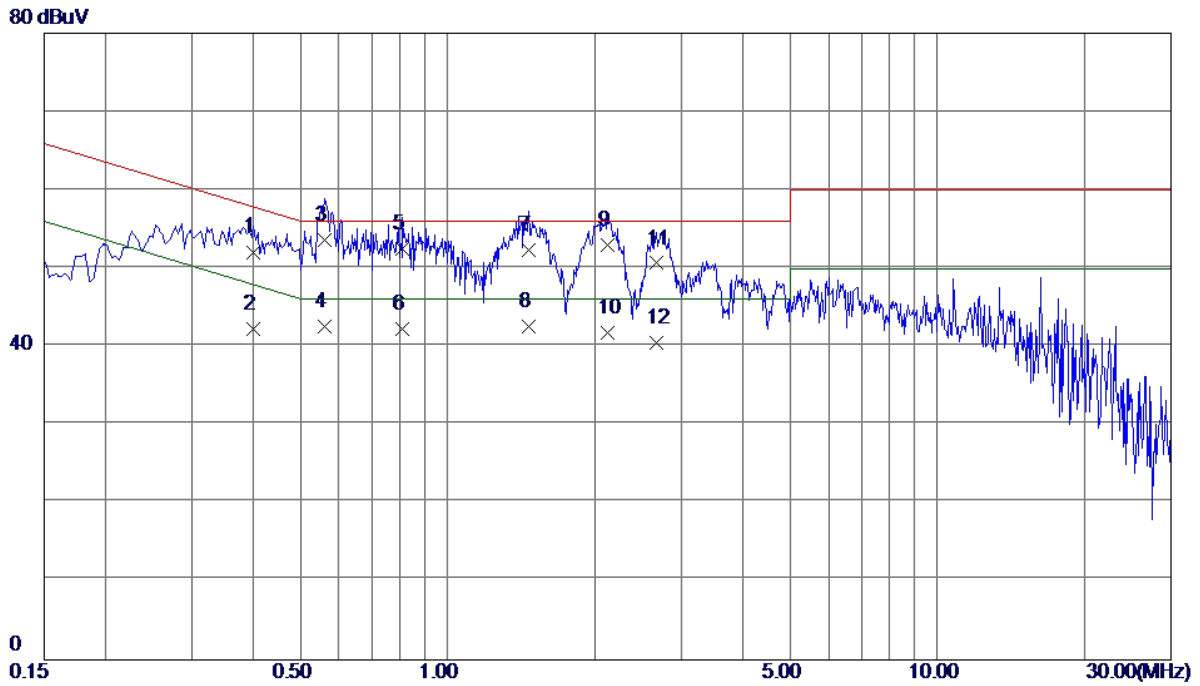

No.	Freq. MHz	Reading Level dBuV	Correct Factor dB	Measure ment dBuV	Limit dBuV	Margin dB	Detector
1	0.4020	42.60	9.48	52.08	57.81	-5.73	QP
2	0.4020	32.80	9.48	42.28	47.81	-5.53	AVG
3 *	0.5620	44.17	9.50	53.67	56.00	-2.33	QP
4	0.5620	33.10	9.50	42.60	46.00	-3.40	AVG
5	0.8100	42.80	9.63	52.43	56.00	-3.57	QP
6	0.8100	32.60	9.63	42.23	46.00	-3.77	AVG
7	1.4620	42.60	9.77	52.37	56.00	-3.63	QP
8	1.4620	32.80	9.77	42.57	46.00	-3.43	AVG
9	2.1260	43.11	9.84	52.95	56.00	-3.05	QP
10	2.1260	31.91	9.84	41.75	46.00	-4.25	AVG
11	2.6700	40.70	9.94	50.64	56.00	-5.36	QP
12	2.6700	30.60	9.94	40.54	46.00	-5.46	AVG

4.3 ASYMMETRIC MODE CONDUCTED EMISSIONS TEST

4.3.1 LIMITS

Requirements for asymmetric mode conducted emissions from Class A equipment

Table clause	Frequency range MHz	Coupling device	Detector type / Bandwidth	Class A voltage limits dB(μV)	Class A current limits dB(μV)
A11.1	0.15 – 0.5	AAN	Quasi Peak / 9 kHz	97 – 87	n/a
	0.5 – 30			87	
	0.15 – 0.5	AAN	Average / 9 kHz	84 – 74	
	0.5 – 30			74	
A11.2	0.15 – 0.5	CVP and current probe	Quasi Peak / 9 kHz	97 – 87	53 – 43
	0.5 – 30			87	43
	0.15 – 0.5	CVP and current probe	Average / 9 kHz	84 – 74	40 – 30
	0.5 – 30			74	30
A11.3	0.15 – 0.5	Current probe	Quasi Peak / 9 kHz	n/a	53 – 43
	0.5 – 30				43
	0.15 – 0.5	Current probe	Average / 9 kHz		40 – 30
	0.5 – 30				30

The choice of coupling device and measurement procedure is defined in Annex C.

AC mains ports that also have the function of a wired network port shall meet the limits given in Table A.9. The measurement shall cover the entire frequency range.

The application of the voltage and/or current limits is dependent on the measurement procedure used. Refer to Table C.1 for applicability.

Testing is required at only one EUT supply voltage and frequency.

Applicable to ports listed above and intended to connect to cables longer than 3 m.

Requirements for asymmetric mode conducted emissions from Class B equipment

Table clause	Frequency range MHz	Coupling device	Detector type / Bandwidth	Class B voltage limits dB(μV)	Class B current limits dB(μV)
A12.1	0.15 – 0.5	AAN	Quasi Peak / 9 kHz	84 – 74	n/a
	0.5 – 30			74	
	0.15 – 0.5	AAN	Average / 9 kHz	74 – 64	
	0.5 – 30			64	
A12.2	0.15 – 0.5	CVP and current probe	Quasi Peak / 9 kHz	84 – 74	40 – 30
	0.5 – 30			74	30
	0.15 – 0.5	CVP and current probe	Average / 9 kHz	74 – 64	30 – 20
	0.5 – 30			64	20
A12.3	0.15 – 0.5	Current probe	Quasi Peak / 9 kHz	n/a	40 – 30
	0.5 – 30				30
	0.15 – 0.5	Current probe	Average / 9 kHz		30 – 20
	0.5 – 30				20

The choice of coupling device and measurement procedure is defined in Annex C.

Screened ports including TV broadcast receiver tuner ports are measured with a common-mode impedance of 150 Ω. This is typically accomplished with the screen terminated by 150 Ω to earth.

AC mains ports that also have the function of a wired network port shall meet the limits given in Table A.10.

The measurement shall cover the entire frequency range.

The application of the voltage and/or current limits is dependent on the measurement procedure used. Refer to Table C.1 for applicability.

Measurement is required at only one EUT supply voltage and frequency.

Applicable to ports listed above and intended to connect to cables longer than 3 m.

NOTE:

(1) The test result calculated as following:

Measurement Value = Reading Level + Correct Factor

Correct Factor = Insertion Loss + Cable Loss + Attenuator Factor(if use)

Margin Level = Measurement Value – Limit Value

4.3.2 MEASUREMENT INSTRUMENTS LIST

Item	Kind of Equipment	Manufacturer	Type No.	Serial No.	Calibrated until
1	Measurement Software	Farad	EZ-EMC Ver.NB-03A 1-01	N/A	N/A
2	50Ω Terminator	SHX	TF2-3G-A	08122901	Mar. 26, 2018
3	TWO-LINE V-NETWORK	R&S	ENV216	100526	Mar. 26, 2018
4	EMI Test Receiver	R&S	ESR3	101862	Sep. 04, 2017
5	Artificial-Mains Network	SCHWARZBECK	NSLK 8127	8127685	Sep. 04, 2017
6	Cable	N/A	RG400 12m	N/A	Mar. 07, 2018
7	ISN	Teseq GmbH	ISN T8	30833	Oct. 21, 2017

Remark: "N/A" denotes no model name, no serial No. or no calibration specified.

All calibration period of equipment list is one year.

4.3.3 TEST PROCEDURE

- a. The EUT was placed 0.8 meters from the horizontal ground plane with EUT being connected to the power mains through a line impedance stabilization network (LISN). All other support equipment powered from additional LISN(s). The LISN provide 50 Ohm/ 50uH of coupling impedance for the measuring instrument.
- b. Interconnecting cables that hang closer than 40 cm to the ground plane shall be folded back and forth in the center forming a bundle 30 to 40 cm long.
- c. I/O cables that are not connected to a peripheral shall be bundled in the center. The end of the cable may be terminated, if required, using the correct terminating impedance. The overall length shall not exceed 1 m.
- d. For the actual test configuration, please refer to the related Item –EUT Test Photos.
- e. **AAN, CP or CVP** at least 80 cm from nearest part of EUT chassis.

NOTE:

- f. The communication function of EUT was executed and AAN was connected between EUT and associated equipment and the AAN was connected directly to reference ground plane.
Measure the voltage at the measurement port of the AAN
Correct the measured voltage by adding the AAN voltage division factor
Compare the corrected voltage with the limit(**For AAN**)
- g Measure the current with a current probe and compare to the current limit(**For CP**)
- h The current shall be measured with the current probe and the results compared with the current limits.
The voltage measured shall be corrected at each frequency of interest as follows:
- if the current margin with respect to the current limit is ≤ 6 dB, the actual current margin shall be subtracted from the measured voltage;
-if the current margin with respect to the current limit is >6 dB, 6 dB shall be subtracted from the measured voltage.
The adjusted voltage shall be compared with the applicable voltage limit.
Both the measured current and the corrected voltage shall be below the applicable current and voltage limits at all frequencies for the EUT to be deemed compliant with this publication.(**For CVP**)

4.3.4 DEVIATION FROM TEST STANDARD

No deviation

4.3.5 TEST SETUP

a) Cable Type: Balanced Unscreened, Screened or Coaxial

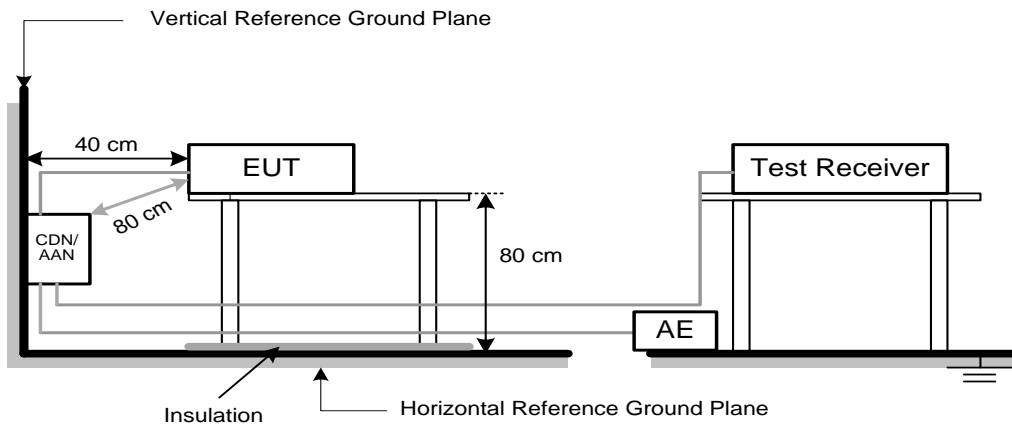

b) Cable Type: Screened or Coaxial

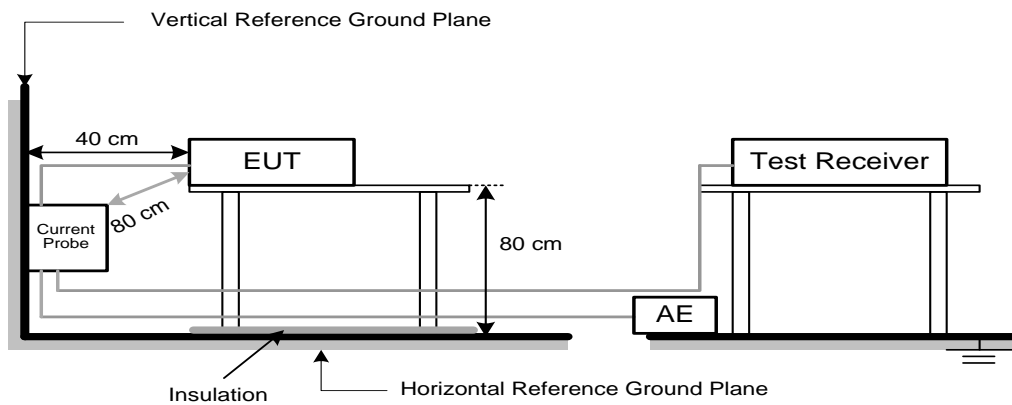

c) Cable Type: Balanced Unscreened, Unbalanced

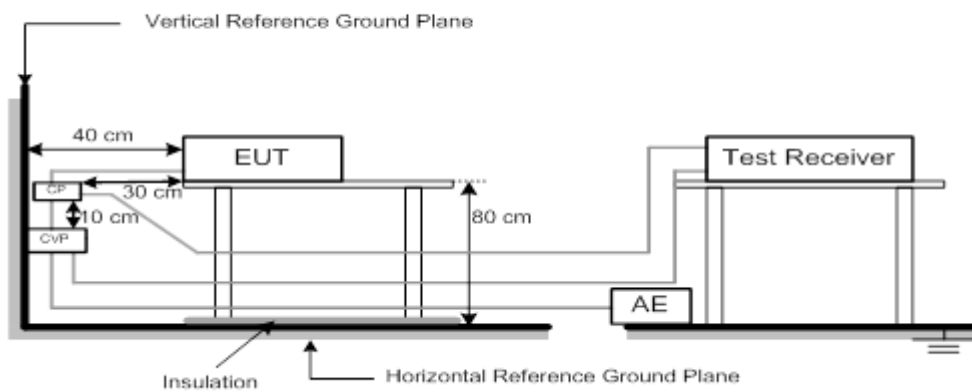

4.3.6 TEST RESULTS

EUT	IP Phone	Model Name	X4
Temperature	25°C	Relative Humidity	53%
Test Voltage	AC 230V/50Hz		
Test Mode	PC Port 100Mbps		
Note	Adapter		
Test Engineer	Jason Yang		

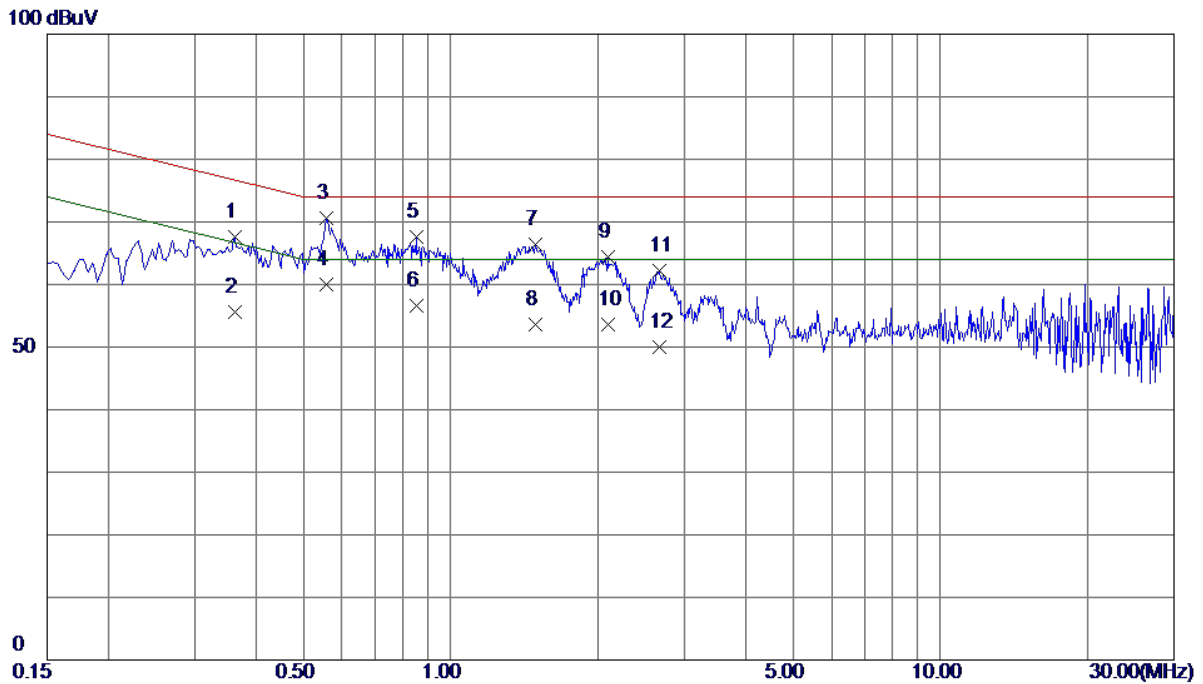

No.	Freq. MHz	Reading Level dBuV	Correct Factor dB	Measure ment dBuV	Limit dBuV	Margin dB	Detector
1	0.3620	57.62	9.92	67.54	76.68	-9.14	QP
2	0.3620	45.60	9.92	55.52	66.68	-11.16	AVG
3 *	0.5580	60.83	9.84	70.67	74.00	-3.33	QP
4	0.5580	50.11	9.84	59.95	64.00	-4.05	AVG
5	0.8500	57.78	9.81	67.59	74.00	-6.41	QP
6	0.8500	46.81	9.81	56.62	64.00	-7.38	AVG
7	1.4900	56.54	9.81	66.35	74.00	-7.65	QP
8	1.4900	43.80	9.81	53.61	64.00	-10.39	AVG
9	2.0940	54.65	9.82	64.47	74.00	-9.53	QP
10	2.0940	43.80	9.82	53.62	64.00	-10.38	AVG
11	2.6700	52.31	9.84	62.15	74.00	-11.85	QP
12	2.6700	40.20	9.84	50.04	64.00	-13.96	AVG

EUT	IP Phone	Model Name	X4
Temperature	25°C	Relative Humidity	53%
Test Voltage	DC 48V		
Test Mode	PC Port 100Mbps		
Note	PoE		
Test Engineer	Jason Yang		

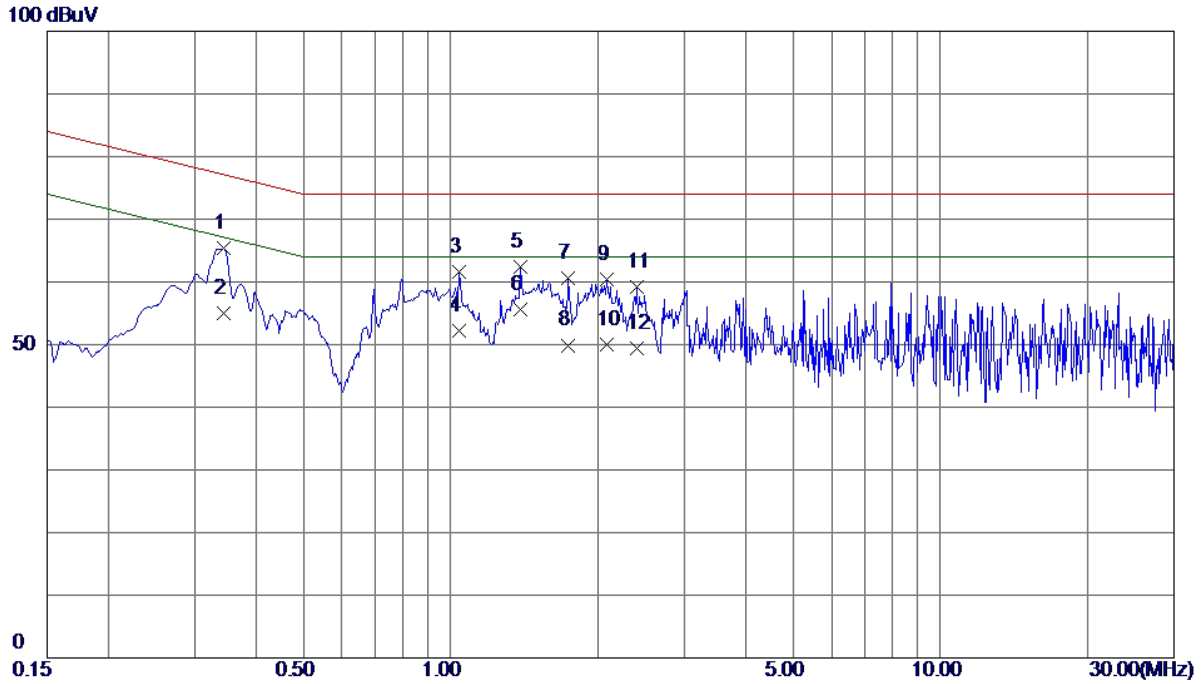

No.	Freq. MHz	Reading Level dBuV	Correct Factor dB	Measure ment dBuV	Limit dBuV	Margin dB	Detector
1	0.3435	55.76	9.58	65.34	77.12	-11.78	QP
2	0.3435	45.50	9.58	55.08	67.12	-12.04	AVG
3	1.0432	52.01	9.65	61.66	74.00	-12.34	QP
4	1.0432	42.50	9.65	52.15	64.00	-11.85	AVG
5	1.3898	52.78	9.68	62.46	74.00	-11.54	QP
6 *	1.3898	45.90	9.68	55.58	64.00	-8.42	AVG
7	1.7385	50.98	9.70	60.68	74.00	-13.32	QP
8	1.7385	40.20	9.70	49.90	64.00	-14.10	AVG
9	2.0873	50.66	9.72	60.38	74.00	-13.62	QP
10	2.0873	40.30	9.72	50.02	64.00	-13.98	AVG
11	2.3955	49.42	9.74	59.16	74.00	-14.84	QP
12	2.3955	39.60	9.74	49.34	64.00	-14.66	AVG

EUT	IP Phone	Model Name	X4
Temperature	25°C	Relative Humidity	53%
Test Voltage	AC 230V/50Hz		
Test Mode	PC Port 10Mbps		
Note	Adapter		
Test Engineer	Jason Yang		

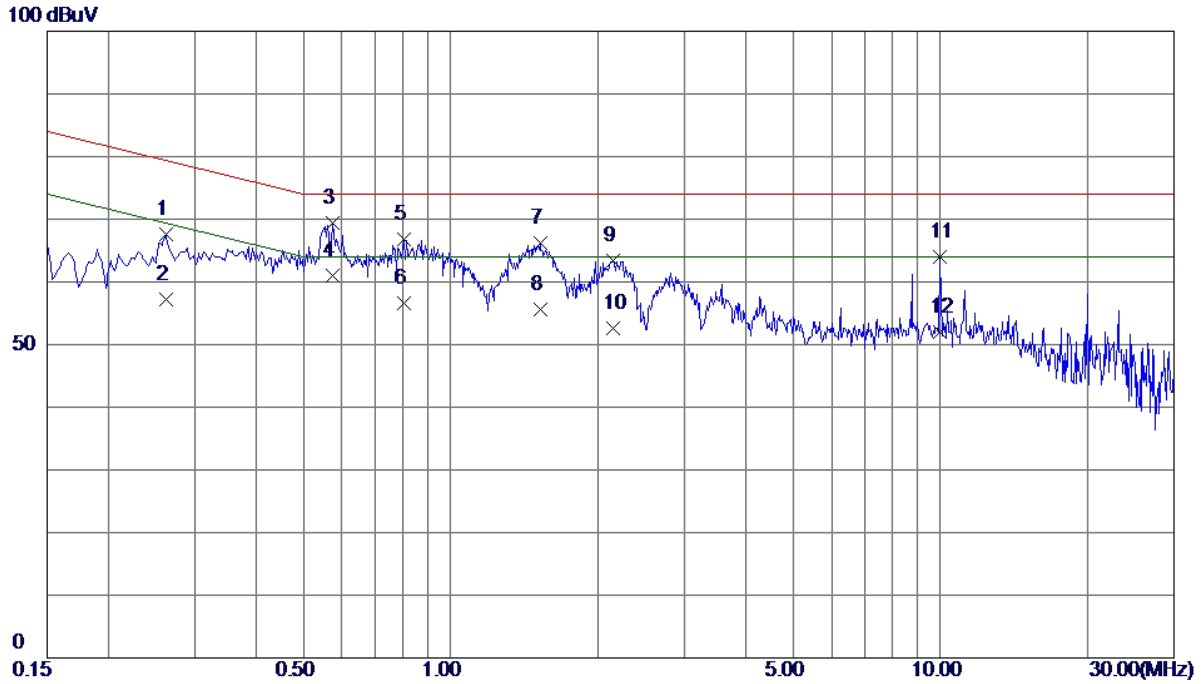

No.	Freq. MHz	Reading Level dBuV	Correct Factor dB	Measure ment dBuV	Limit dBuV	Margin dB	Detector
1	0.2620	57.60	10.03	67.63	79.37	-11.74	QP
2	0.2620	47.20	10.03	57.23	69.37	-12.14	AVG
3	0.5740	59.50	9.84	69.34	74.00	-4.66	QP
4 *	0.5740	51.21	9.84	61.05	64.00	-2.95	AVG
5	0.8020	56.95	9.82	66.77	74.00	-7.23	QP
6	0.8020	46.70	9.82	56.52	64.00	-7.48	AVG
7	1.5260	56.44	9.81	66.25	74.00	-7.75	QP
8	1.5260	45.80	9.81	55.61	64.00	-8.39	AVG
9	2.1500	53.58	9.82	63.40	74.00	-10.60	QP
10	2.1500	42.71	9.82	52.53	64.00	-11.47	AVG
11	10.0060	53.94	10.04	63.98	74.00	-10.02	QP
12	10.0060	41.90	10.04	51.94	64.00	-12.06	AVG

EUT	IP Phone	Model Name	X4
Temperature	25°C	Relative Humidity	53%
Test Voltage	DC 48V		
Test Mode	PC Port 10Mbps		
Note	PoE		
Test Engineer	Jason Yang		

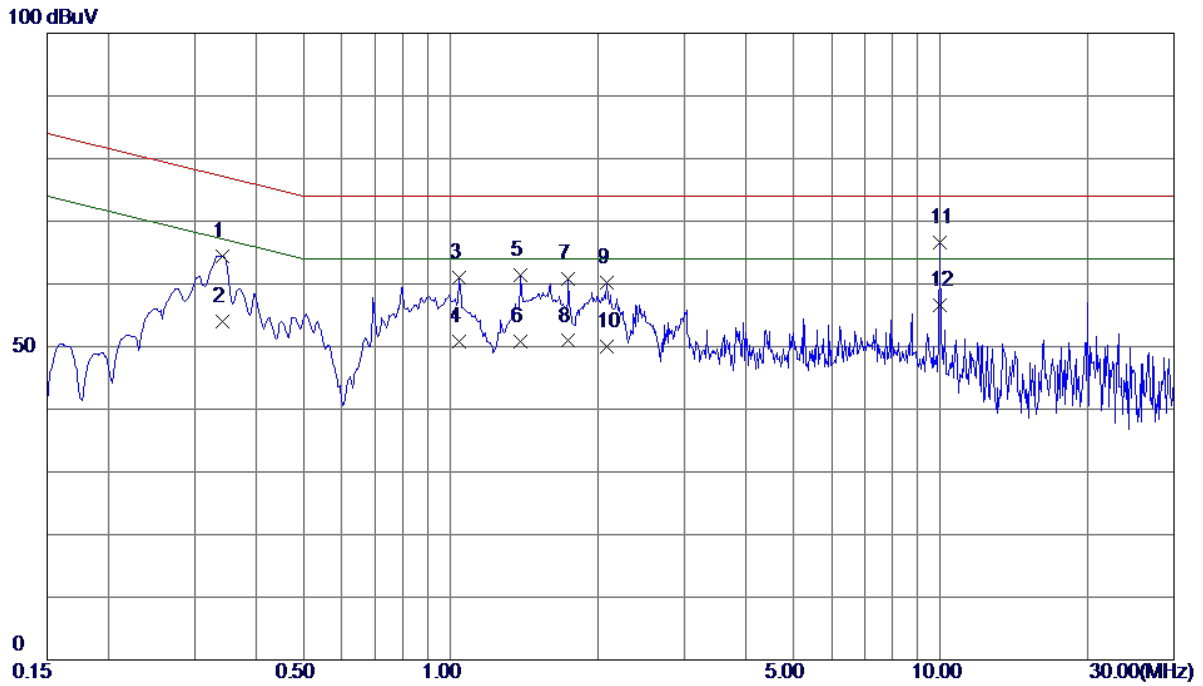

No.	Freq. MHz	Reading Level dBuV	Correct Factor dB	Measure ment dBuV	Limit dBuV	Margin dB	Detector
1	0.3412	54.91	9.58	64.49	77.17	-12.68	QP
2	0.3412	44.50	9.58	54.08	67.17	-13.09	AVG
3	1.0432	51.41	9.65	61.06	74.00	-12.94	QP
4	1.0432	41.20	9.65	50.85	64.00	-13.15	AVG
5	1.3920	51.80	9.68	61.48	74.00	-12.52	QP
6	1.3920	41.20	9.68	50.88	64.00	-13.12	AVG
7	1.7385	51.06	9.70	60.76	74.00	-13.24	QP
8	1.7385	41.20	9.70	50.90	64.00	-13.10	AVG
9	2.0873	50.56	9.72	60.28	74.00	-13.72	QP
10	2.0873	40.20	9.72	49.92	64.00	-14.08	AVG
11 *	10.0004	56.51	10.05	66.56	74.00	-7.44	QP
12	10.0004	46.50	10.05	56.55	64.00	-7.45	AVG

EUT	IP Phone	Model Name	X4
Temperature	25°C	Relative Humidity	53%
Test Voltage	AC 230V/50Hz		
Test Mode	Internet Port 100Mbps		
Note	Adapter		
Test Engineer	Jason Yang		

100 dBuV

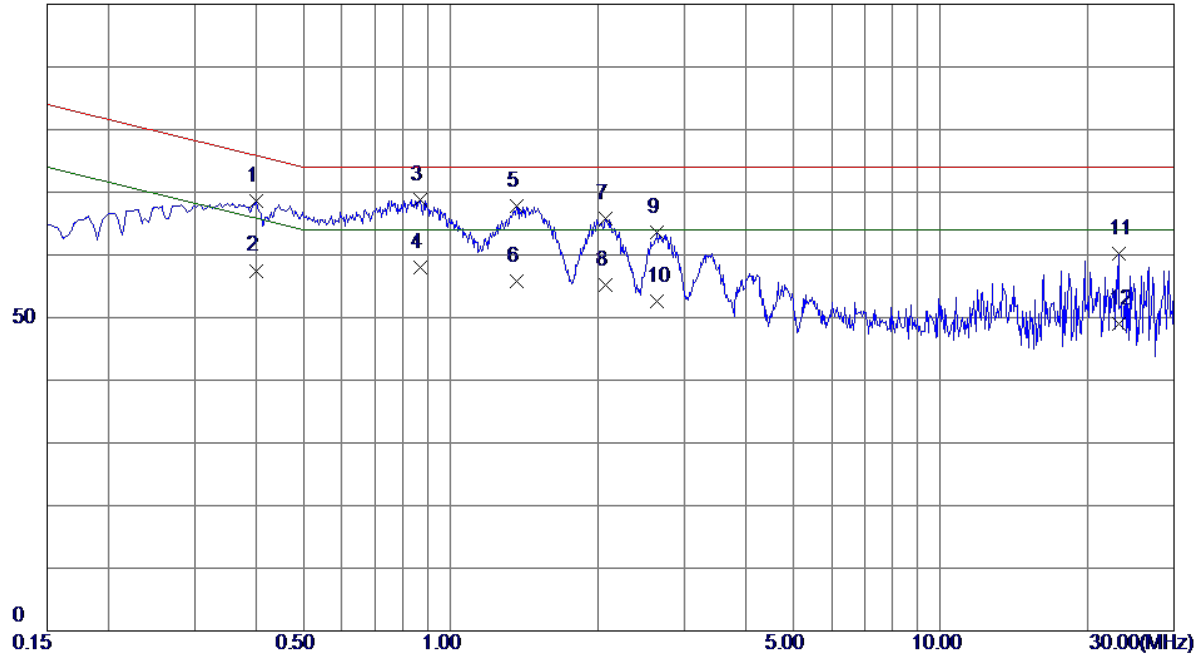

No.	Freq. MHz	Reading Level dBuV	Correct Factor dB	Measure ment dBuV	Limit dBuV	Margin dB	Detector
1	0.4020	58.66	9.90	68.56	75.81	-7.25	QP
2	0.4020	47.60	9.90	57.50	65.81	-8.31	AVG
3 *	0.8660	59.02	9.81	68.83	74.00	-5.17	QP
4	0.8660	48.21	9.81	58.02	64.00	-5.98	AVG
5	1.3619	57.97	9.81	67.78	74.00	-6.22	QP
6	1.3619	45.90	9.81	55.71	64.00	-8.29	AVG
7	2.0780	55.92	9.82	65.74	74.00	-8.26	QP
8	2.0780	45.30	9.82	55.12	64.00	-8.88	AVG
9	2.6420	53.70	9.84	63.54	74.00	-10.46	QP
10	2.6420	42.70	9.84	52.54	64.00	-11.46	AVG
11	23.1299	49.70	10.48	60.18	74.00	-13.82	QP
12	23.1299	38.61	10.48	49.09	64.00	-14.91	AVG

EUT	IP Phone	Model Name	X4
Temperature	25°C	Relative Humidity	53%
Test Voltage	DC 48V		
Test Mode	Internet Port 100Mbps		
Note	PoE		
Test Engineer	Jason Yang		

100 dBuV

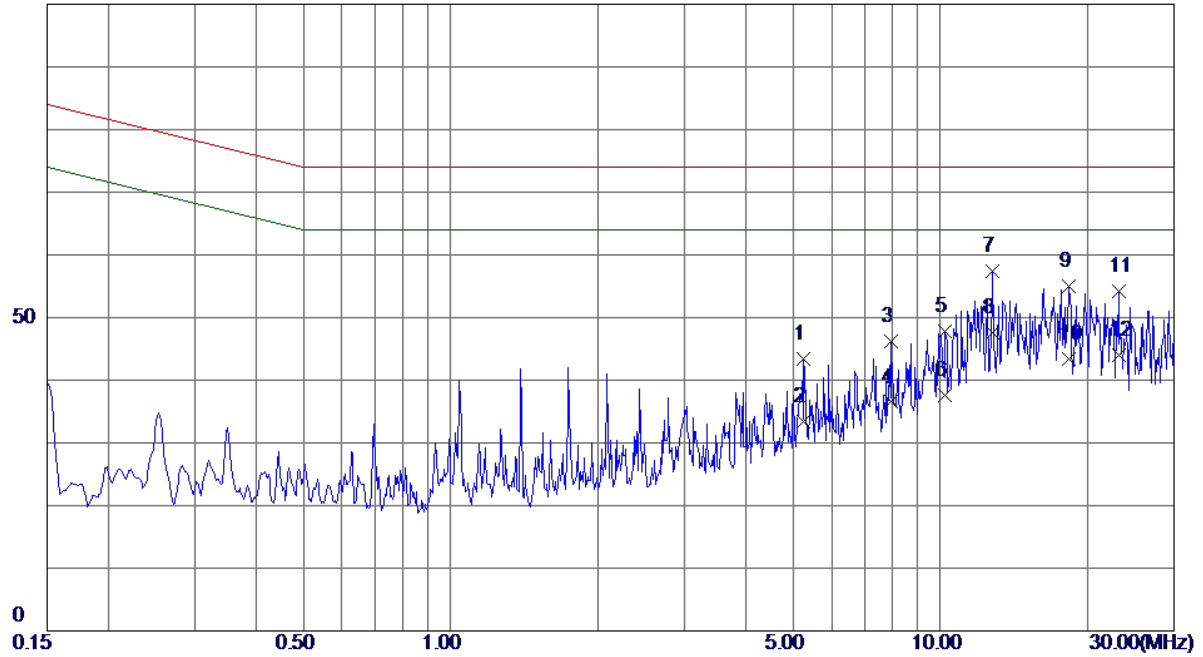

No.	Freq. MHz	Reading Level dBuV	Correct Factor dB	Measure ment dBuV	Limit dBuV	Margin dB	Detector
1	5.2371	33.56	9.85	43.41	74.00	-30.59	QP
2	5.2371	23.50	9.85	33.35	64.00	-30.65	AVG
3	7.9237	36.19	9.99	46.18	74.00	-27.82	QP
4	7.9237	26.51	9.99	36.50	64.00	-27.50	AVG
5	10.2435	37.65	10.06	47.71	74.00	-26.29	QP
6	10.2435	27.49	10.06	37.55	64.00	-26.45	AVG
7	12.8085	47.29	10.12	57.41	74.00	-16.59	QP
8 *	12.8085	37.50	10.12	47.62	64.00	-16.38	AVG
9	18.2445	44.77	10.28	55.05	74.00	-18.95	QP
10	18.2445	33.20	10.28	43.48	64.00	-20.52	AVG
11	23.1292	43.75	10.45	54.20	74.00	-19.80	QP
12	23.1292	33.50	10.45	43.95	64.00	-20.05	AVG

EUT	IP Phone	Model Name	X4
Temperature	25°C	Relative Humidity	53%
Test Voltage	AC 230V/50Hz		
Test Mode	Internet Port 10Mbps		
Note	Adapter		
Test Engineer	Jason Yang		

100 dBuV

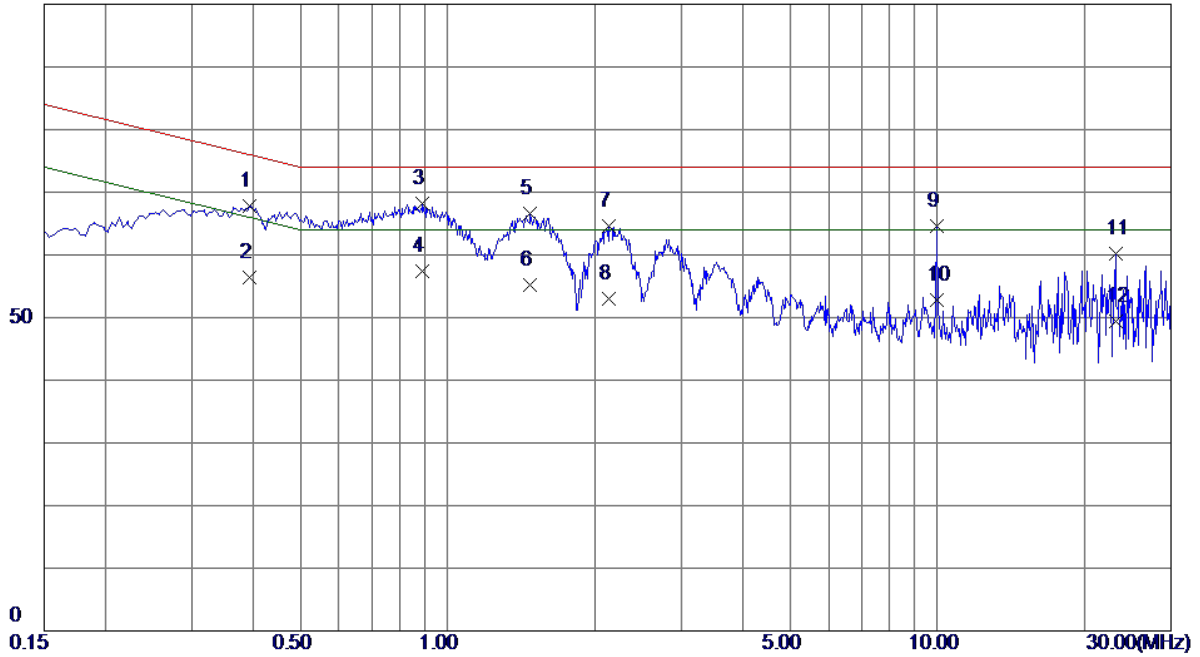

No.	Freq. MHz	Reading Level dBuV	Correct Factor dB	Measure ment dBuV	Limit dBuV	Margin dB	Detector
1	0.3940	57.92	9.91	67.83	75.98	-8.15	QP
2	0.3940	46.49	9.91	56.40	65.98	-9.58	AVG
3 *	0.8900	58.41	9.81	68.22	74.00	-5.78	QP
4	0.8900	47.50	9.81	57.31	64.00	-6.69	AVG
5	1.4740	56.84	9.81	66.65	74.00	-7.35	QP
6	1.4740	45.30	9.81	55.11	64.00	-8.89	AVG
7	2.1340	54.78	9.82	64.60	74.00	-9.40	QP
8	2.1340	43.21	9.82	53.03	64.00	-10.97	AVG
9	10.0020	54.51	10.04	64.55	74.00	-9.45	QP
10	10.0020	42.80	10.04	52.84	64.00	-11.16	AVG
11	23.1299	49.64	10.48	60.12	74.00	-13.88	QP
12	23.1299	38.91	10.48	49.39	64.00	-14.61	AVG

EUT	IP Phone	Model Name	X4
Temperature	25°C	Relative Humidity	53%
Test Voltage	DC 48V		
Test Mode	Internet Port 10Mbps		
Note	PoE		
Test Engineer	Jason Yang		

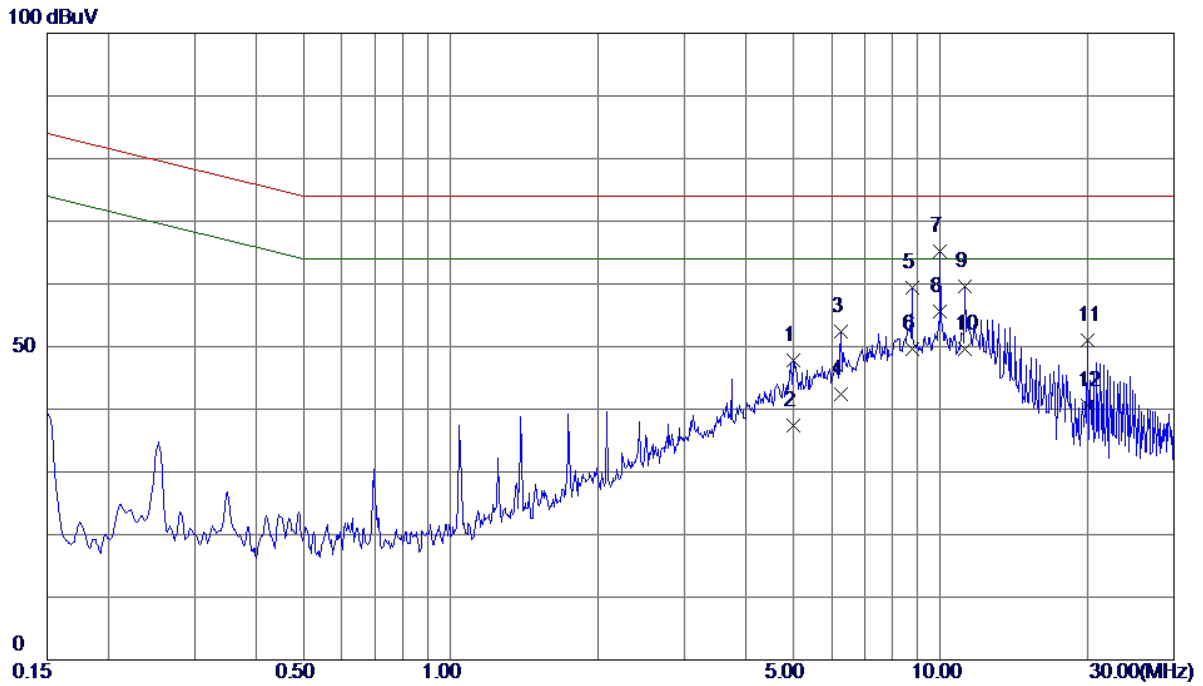

No.	Freq. MHz	Reading Level dBuV	Correct Factor dB	Measure ment dBuV	Limit dBuV	Margin dB	Detector
1	5.0010	37.88	9.84	47.72	74.00	-26.28	QP
2	5.0010	27.50	9.84	37.34	64.00	-26.66	AVG
3	6.2498	42.47	9.90	52.37	74.00	-21.63	QP
4	6.2498	32.50	9.90	42.40	64.00	-21.60	AVG
5	8.7518	49.33	10.02	59.35	74.00	-14.65	QP
6	8.7518	39.50	10.02	49.52	64.00	-14.48	AVG
7	10.0004	55.17	10.05	65.22	74.00	-8.78	QP
8 *	10.0004	45.50	10.05	55.55	64.00	-8.45	AVG
9	11.2493	49.52	10.08	59.60	74.00	-14.40	QP
10	11.2493	39.50	10.08	49.58	64.00	-14.42	AVG
11	19.9995	40.73	10.34	51.07	74.00	-22.93	QP
12	19.9995	30.20	10.34	40.54	64.00	-23.46	AVG

4.4 HARMONIC CURRENT EMISSIONS TEST

4.4.1 LIMITS

EN 61000-3-2						
Equipment Category	Harmonic Order n	Max. Permissible Harmonic Current A	Equipment Category	Harmonic Order n	Max. Permissible Harmonic Current A mA/w	
Class A	Odd Harmonics		Class D	Odd Harmonics only		
	3	2.30		3	2.30	3.4
	5	1.14		5	1.14	1.9
	7	0.77		7	0.77	1.0
	9	0.40		9	0.40	0.5
	11	0.33		11	0.33	0.35
	13	0.21		13	0.21	0.30
	15≤n≤39	0.15 x 15/n		15≤n≤39	0.15 x 15/n	3.85/n
	Even Harmonics					
	2	1.08				
	4	0.43				
	6	0.30				
	8≤n≤40	0.23 x 8/n				

4.4.2 MEASUREMENT INSTRUMENTS LIST

Item	Kind of Equipment	Manufacturer	Type No.	Serial No.	Calibrated until
1	Harmonics and Flicker Analyzer	California Instruments	PACS-1	72344	Jul. 26, 2017
2	3KVA AC Power source	California Instruments	3001ix	56309	Jul. 26, 2017
3	Measurement Software	California	CTS4.0 Version 4.9	N/A	N/A

Remark: "N/A" denotes no model name, no serial No. or no calibration specified.
All calibration period of equipment list is one year.

4.4.3 TEST PROCEDURE

- a. The EUT was placed on the top of a wooden table 0.8 meters above the ground and operated to produce the maximum harmonic components under normal operating conditions.
- b. The classification of EUT is according to of EN 61000-3-2. The EUT is classified as follows:
 - Class A: Balanced three-phase equipment, Household appliances excluding equipment as Class D, Tools excluding portable tools, Dimmers for incandescent lamps, audio equipment, equipment not specified in one of the three other classes.
 - Class B: Portable tools; Arc welding equipment which is not professional equipment.
 - Class C: Lighting equipment.
 - Class D: Equipment having a specified power less than or equal to 600 W of the following types: Personal computers and personal computer monitors and television receivers.
- c. The correspondent test program of test instrument to measure the current harmonics emanated from EUT is chosen. The measure time shall be not less than the time necessary for the EUT to be exercised.

4.4.4 DEVIATION FROM TEST STANDARD

No deviation

4.4.5 TEST SETUP

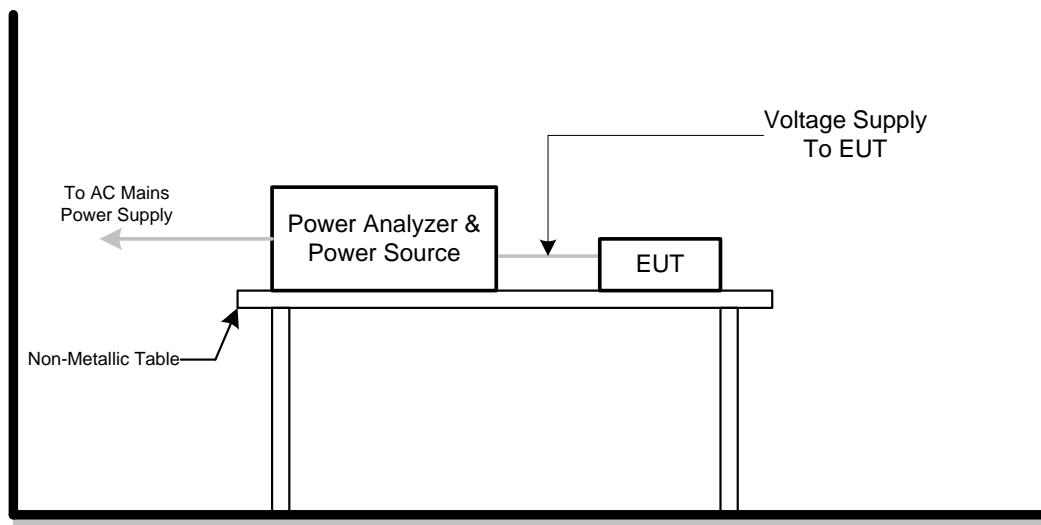

4.4.6 TEST RESULTS

Harmonic - Class A			
EUT	IP Phone	Model Name	X4
Temperature	25°C	Relative Humidity	55%
Test Voltage	AC 230V/50Hz		
Test Mode	Handfree		

Current & voltage waveforms

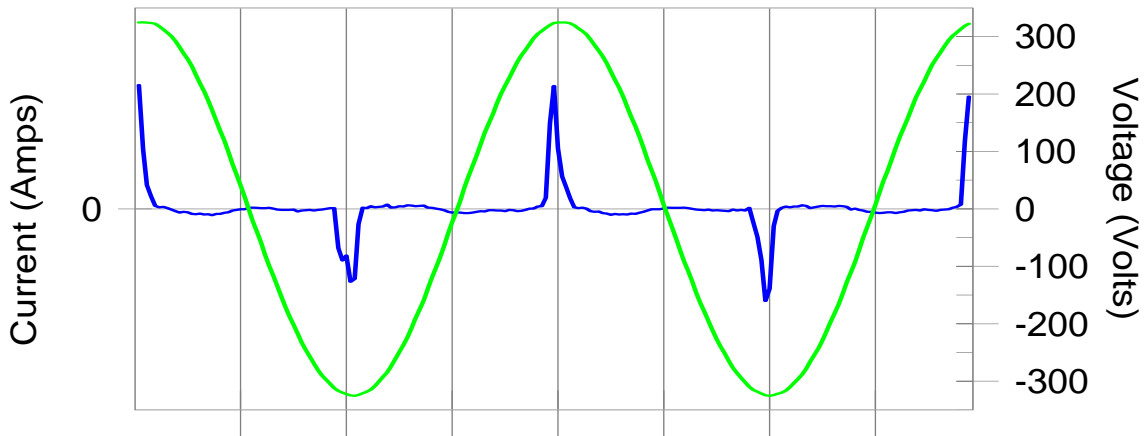

Harmonics and Class A limit line European Limits

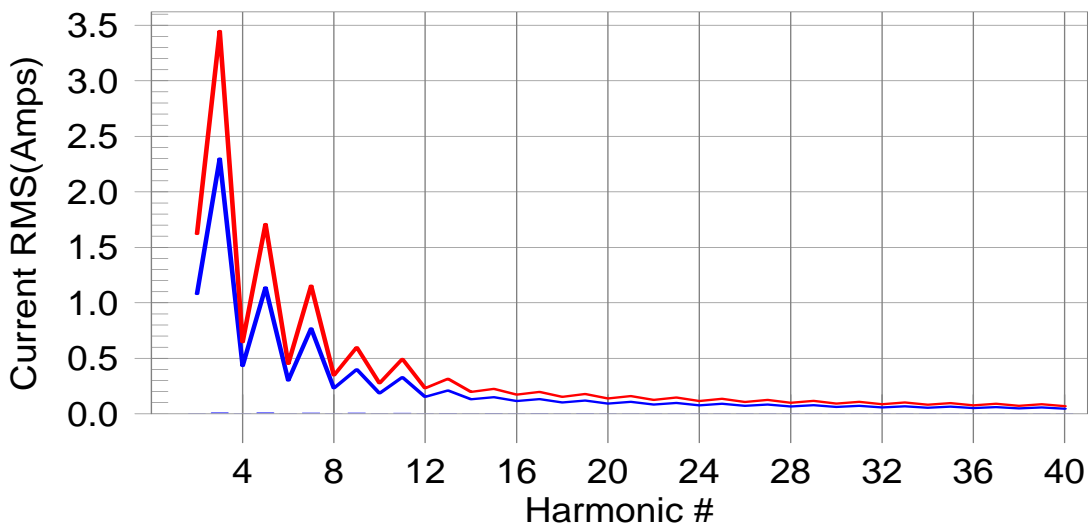

Test result: Pass Worst harmonic was #11 with 1.2% of the limit.

Current Test Result Summary (Run time)			
EUT	IP Phone	Model Name	X4
Temperature	25°C	Relative Humidity	55%
Test Voltage	AC 230V/50Hz		
Test Mode	Handfree		

Highest parameter values during test:

V_RMS (Volts): 229.97	Frequency(Hz): 50.00
I_Peak (Amps): 0.126	I_RMS (Amps): 0.022
I_Fund (Amps): 0.009	Crest Factor: 6.160
Power (Watts): 2.1	Power Factor: 0.449

Harm#	Harms(avg)	100%Limit	%of Limit	Harms(max)	150%Limit	%of Limit	Status
2	0.001	1.080	N/A	0.001	1.620	N/A	Pass
3	0.009	2.300	0.4	0.010	3.450	0.3	Pass
4	0.001	0.430	N/A	0.001	0.645	N/A	Pass
5	0.008	1.140	0.7	0.008	1.710	0.5	Pass
6	0.000	0.300	N/A	0.000	0.450	N/A	Pass
7	0.007	0.770	0.9	0.007	1.155	0.6	Pass
8	0.000	0.230	N/A	0.000	0.345	N/A	Pass
9	0.007	0.400	1.6	0.007	0.600	1.1	Pass
10	0.000	0.184	N/A	0.000	0.276	N/A	Pass
11	0.006	0.330	1.7	0.006	0.495	1.2	Pass
12	0.000	0.153	N/A	0.000	0.230	N/A	Pass
13	0.005	0.210	N/A	0.005	0.315	N/A	Pass
14	0.000	0.131	N/A	0.000	0.197	N/A	Pass
15	0.004	0.150	N/A	0.004	0.225	N/A	Pass
16	0.000	0.115	N/A	0.000	0.173	N/A	Pass
17	0.003	0.132	N/A	0.003	0.198	N/A	Pass
18	0.000	0.102	N/A	0.000	0.153	N/A	Pass
19	0.002	0.118	N/A	0.002	0.178	N/A	Pass
20	0.000	0.092	N/A	0.000	0.138	N/A	Pass
21	0.002	0.107	N/A	0.002	0.161	N/A	Pass
22	0.000	0.084	N/A	0.000	0.125	N/A	Pass
23	0.001	0.098	N/A	0.001	0.147	N/A	Pass
24	0.000	0.077	N/A	0.000	0.115	N/A	Pass
25	0.001	0.090	N/A	0.001	0.135	N/A	Pass
26	0.000	0.071	N/A	0.000	0.107	N/A	Pass
27	0.001	0.083	N/A	0.001	0.125	N/A	Pass
28	0.000	0.066	N/A	0.000	0.099	N/A	Pass
29	0.001	0.078	N/A	0.001	0.116	N/A	Pass
30	0.000	0.061	N/A	0.000	0.092	N/A	Pass
31	0.001	0.073	N/A	0.001	0.109	N/A	Pass
32	0.000	0.058	N/A	0.000	0.086	N/A	Pass
33	0.001	0.068	N/A	0.001	0.102	N/A	Pass
34	0.000	0.054	N/A	0.000	0.081	N/A	Pass
35	0.001	0.064	N/A	0.001	0.096	N/A	Pass
36	0.000	0.051	N/A	0.000	0.077	N/A	Pass
37	0.000	0.061	N/A	0.000	0.091	N/A	Pass
38	0.000	0.048	N/A	0.000	0.073	N/A	Pass
39	0.000	0.058	N/A	0.000	0.087	N/A	Pass
40	0.000	0.046	N/A	0.000	0.069	N/A	Pass

Voltage Source Verification Data (Run time)			
EUT	IP Phone	Model Name	X4
Temperature	25°C	Relative Humidity	55%
Test Voltage	AC 230V/50Hz		
Test Mode	Handfree		

Highest parameter values during test:

Voltage (Vrms):229.97	Frequency(Hz): 50.00
I_Peak (Amps):0.126	I_RMS (Amps): 0.022
I_Fund (Amps):0.009	Crest Factor: 6.160
Power (Watts): 2.1	Power Factor: 0.449

Harm#	Harmonics V-rms	Limit V-rms	% of Limit	Status
2	0.120	0.460	25.99	OK
3	0.689	2.069	33.32	OK
4	0.055	0.460	11.99	OK
5	0.148	0.920	16.13	OK
6	0.026	0.460	5.75	OK
7	0.038	0.690	5.54	OK
8	0.016	0.460	3.52	OK
9	0.040	0.460	8.74	OK
10	0.020	0.460	4.37	OK
11	0.020	0.230	8.51	OK
12	0.015	0.230	6.64	OK
13	0.013	0.230	5.64	OK
14	0.008	0.230	3.45	OK
15	0.012	0.230	5.07	OK
16	0.013	0.230	5.66	OK
17	0.008	0.230	3.49	OK
18	0.013	0.230	5.59	OK
19	0.009	0.230	3.99	OK
20	0.015	0.230	6.44	OK
21	0.009	0.230	3.94	OK
22	0.013	0.230	5.58	OK
23	0.007	0.230	3.21	OK
24	0.005	0.230	2.37	OK
25	0.008	0.230	3.35	OK
26	0.009	0.230	3.72	OK
27	0.007	0.230	2.92	OK
28	0.007	0.230	2.96	OK
29	0.008	0.230	3.35	OK
30	0.006	0.230	2.43	OK
31	0.003	0.230	1.40	OK
32	0.006	0.230	2.65	OK
33	0.008	0.230	3.58	OK
34	0.003	0.230	1.16	OK
35	0.003	0.230	1.31	OK
36	0.003	0.230	1.29	OK
37	0.005	0.230	2.23	OK
38	0.002	0.230	1.08	OK
39	0.003	0.230	1.40	OK
40	0.005	0.230	2.29	OK

4.5 VOLTAGE CHANGES, VOLTAGE FLUCTUATIONS AND FLICKER TEST

4.5.1 LIMITS

Tests	Limits	Descriptions
	EN 61000-3-3	
Pst	≤ 1.0 , $T_p= 10$ min.	Short Term Flicker Indicator
Plt	≤ 0.65 , $T_p=2$ hr.	Long Term Flicker Indicator
dc	$\leq 3.3\%$	Relative Steady-State V-Chang
dmax	$\leq 4\%$	Maximum Relative V-change
d (t)	$\leq 3.3\%$ for > 500 ms	Relative V-change characteristic

4.5.2 MEASUREMENT INSTRUMENTS LIST

Item	Kind of Equipment	Manufacturer	Type No.	Serial No.	Calibrated until
1	Harmonics and Flicker Analyzer	California Instruments	PACS-1	72344	Jul. 26, 2017
2	3KVA AC Power source	California Instruments	3001ix	56309	Jul. 26, 2017
3	Measurement Software	California	CTS4.0 Version 4.9	N/A	N/A

Remark: "N/A" denotes no model name, no serial No. or no calibration specified.

All calibration period of equipment list is one year.

4.5.3 TEST PROCEDURE

- a. Tests was performed according to the Test Conditions/Assessment of Voltage Fluctuations specified in EN 61000-3-3 depend on which standard adopted for compliance measurement.
- b. All types of harmonic current and/or voltage fluctuation in this report are assessed by direct measurement using flicker-meter.

4.5.4 DEVIATION FROM TEST STANDARD

No deviation

4.5.5 TESTSETUP

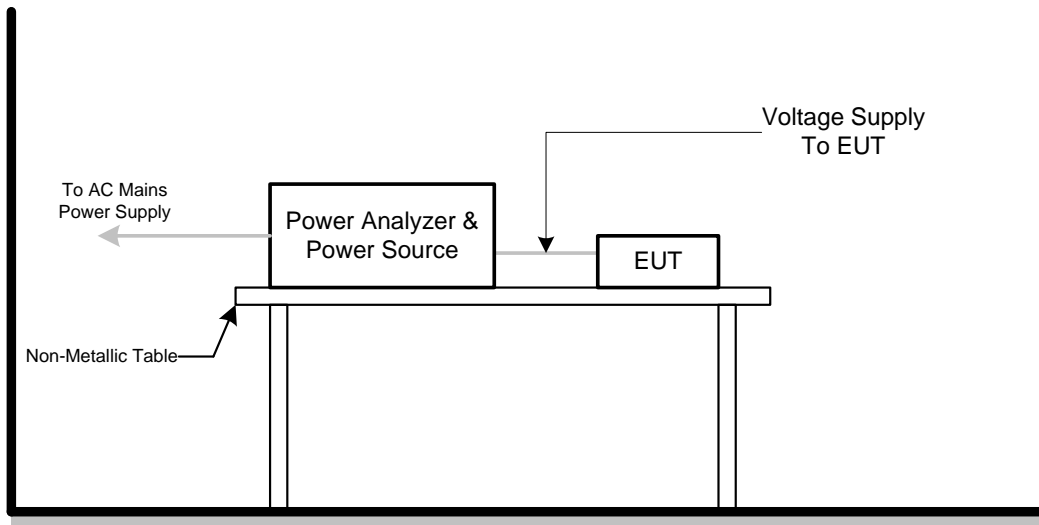

4.5.6 TEST RESULTS

EUT	IP Phone	Model Name	X4
Temperature	25°C	Relative Humidity	55%
Test Voltage	AC 230V/50Hz		
Test Mode	Handfree		

Psti and limit line

European Limits

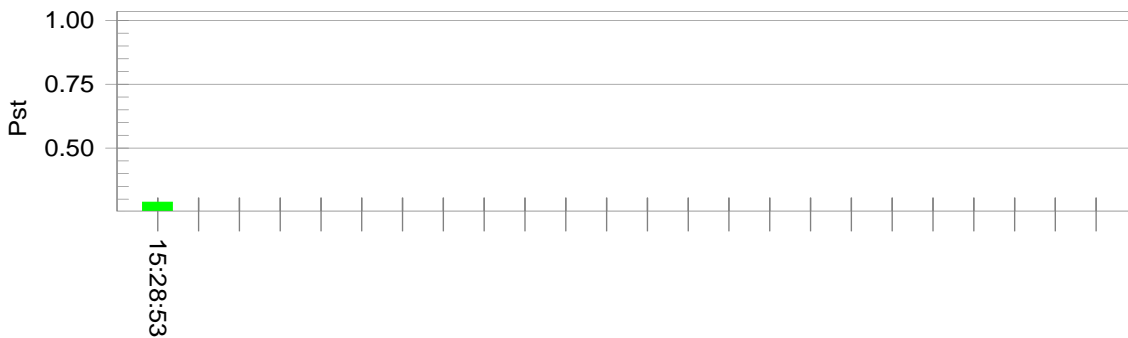

Plt and limit line

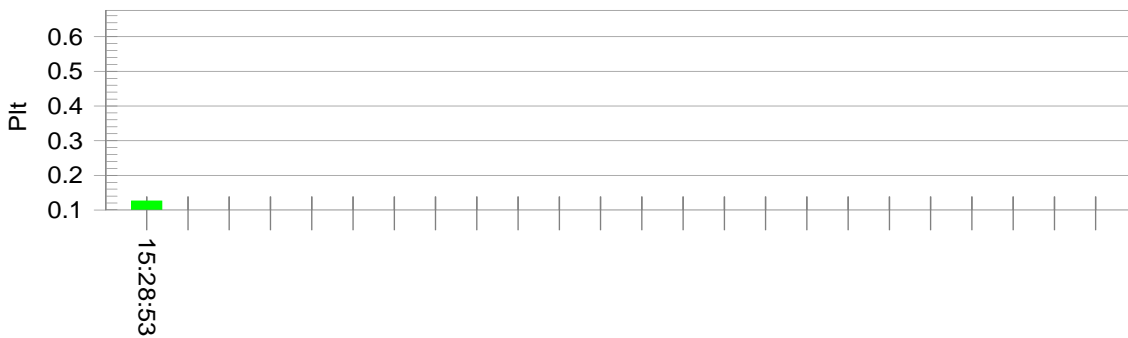

Parameter values recorded during the test:

Vrms at the end of test (Volt):	229.93		
Highest dt (%):	0.00	Test limit (%):	N/A N/A
T-max (mS):	0	Test limit (mS):	500.0 Pass
Highest dc (%):	0.00	Test limit (%):	3.30 Pass
Highest dmax (%):	0.03	Test limit (%):	4.00 Pass
Highest Pst (10 min. period):	0.288	Test limit:	1.000 Pass
Highest Plt (2 hr. period):	0.126	Test limit:	0.650 Pass

5. EMC IMMUNITY TEST

5.1 STANDARD COMPLIANCE/SEVERITY LEVEL/CRITERIA

Tests Standard No.	Test Specification Level / Test Mode	Test Ports	Criteria
Electrostatic discharge EN 61000-4-2 (ESD)	±8 kV air discharge ±4 kV contact discharge (Direct Mode)	Enclosure	B
	±4kV HCP discharge ±4kV VCP discharge (Indirect Mode)	Enclosure	B
Radiated, radio-frequency, electromagnetic field immunity EN 61000-4-3 (RS)	80 MHz to 1000 MHz 3V/m(unmodulated, r.m.s), 1 kHz, 80%, AM modulated	Enclosure	A
Electrical fast transient/burst immunity EN 61000-4-4 (EFT/Burst)	±0.5kV(peak) 5/50ns Tr/Th 5kHz Repetition Frequency (100kHz Repetition Frequency for xDSL equipment)	Signal ports and telecommunication ports (Only applicable to cable length>3 m)	B
	±0.5kV(peak) 5/50ns Tr/Th 5kHz Repetition Frequency	DC Power Ports	B
	±1 kV(peak) 5/50ns Tr/Th 5kHz Repetition Frequency	AC Power Ports	B
Surge immunity EN 61000-4-5 (Surges)	±1 kV(peak) 10/700 Tr/Th μs(NOTE) (without primary protection)	Signal ports and telecommunication ports (applicable only to ports connect directly to outdoor cables)	C
	±4 kV(peak) 10/700 Tr/Th μs(NOTE) (with primary protectors fitted)		C
	±0.5 kV(peak) 1.2/50(8/20) Tr/Th μs	DC Power Ports (applicable only to ports connect directly to outdoor cables)	B
	±1 kV(peak) 1.2/50(8/20) Tr/Th μs (line to line)	AC Power Ports	B
	±2 kV(peak) 1.2/50(8/20) Tr/Th μs (line to earth or ground)		B

Immunity to conducted disturbances, induced by radio-frequency fields EN 61000-4-6 (Injected Current)	0.15 MHz to 80 MHz 3V(unmodulated, r.m.s), 1kHz 80%, AM 150Ω source impedance	Signal ports and telecommunication ports (Only applicable to cable length>3 m)	A
	0.15 MHz to 80 MHz 3V(unmodulated, r.m.s), 1kHz 80%, AM 150Ω source impedance	DC Power Ports	A
	0.15 MHz to 80 MHz 3V(unmodulated, r.m.s), 1kHz 80%, AM 150Ω source impedance	AC Power Ports	A
Power frequency magnetic field immunity EN 61000-4-8 (PFMF)	50 Hz or 60Hz, 1A/m(r.m.s) μs	Enclosure	A
Voltage dips, short interruptions and voltage variations immunity EN 61000-4-11 (Voltage Interruption/Dips)	Voltage reduction > 95% 0.5 period Voltage reduction 30% 25 periods Voltage reduction > 95% 250 periods	AC Power Ports	B C C

Note.

Where the coupling network for the 10/700 μs waveform affects the functioning of high speed data ports, the test shall be carried out using a 1,2/50 (8/20) μs waveform and appropriate coupling network.

5.2 GENERAL PERFORMANCE CRITERIA

According to **EN55024** standard, the general performance criteria as following:

<p>Criterion A</p>	<p>The equipment shall continue to operate as intended without operator intervention. No degradation of performance or loss of function is allowed below a performance level specified by the manufacturer when the equipment is used as intended. The performance level may be replaced by a permissible loss of performance.</p> <p>If the minimum performance level or the permissible performance loss is not specified by the manufacturer, then either of these may be derived from the product description and documentation, and by what the user product description and documentation, and by what the user may reasonably expect from the equipment if used as intended.</p>
<p>Criterion B</p>	<p>After the test, the equipment shall continue to operate as intended without operator intervention. No degradation of performance or loss of function is allowed, after the application of the phenomenon below a performance level specified by the manufacturer, when the equipment is used as intended. The performance level may be replaced by a permissible loss of performance.</p> <p>During the test, degradation of performance is allowed. However, no change of operating state if stored data allowed to persist after the test. If the minimum performance level (or the permissible performance loss) is not specified by the manufacturer, then either of these may be derived from the product description and documentation, and by what the user may reasonably expect from the equipment if used as intended.</p>
<p>Criterion C</p>	<p>Loss of function is allowed, provided the function is self-recoverable, or can be restored by the operation of the controls by the user in accordance with the manufacturer's instructions.</p> <p>Functions, and/or information stored in non-volatile memory, or protected by a battery backup, shall not be lost.</p>

5.3 ELECTROSTATIC DISCHARGE IMMUNITY TEST (ESD)

5.3.1 TEST SPECIFICATION

Basic Standard	EN 61000-4-2
Discharge Impedance	330 ohm / 150 pF
Required Performance	B
Discharge Voltage	Air Discharge: ± 2 kV, ± 4 kV, ± 8 kV (Direct) Contact Discharge: ± 2 kV, ± 4 kV (Direct/Indirect)
Polarity	Positive & Negative
Number of Discharge	Air Discharge: min. 20 times at each test point Contact Discharge: min. 200 times in total
Discharge Mode	Single Discharge
Discharge Period	1 second minimum

5.3.2 MEASUREMENT INSTRUMENTS

Item	Kind of Equipment	Manufacturer	Type No.	Serial No.	Calibrated until
1	ESD Generator	TESEQ AG	NSG 437	450	Nov. 03, 2017

Remark: "N/A" denotes no model name, no serial No. or no calibration specified.
All calibration period of equipment list is one year.

5.3.3 TEST PROCEDURE

The test generator necessary to perform direct and indirect application of discharges to the EUT in the following manner:

- a. Contact discharge was applied to conductive surfaces (Direct) and coupling planes (Indirect) of the EUT.

During the test, it was performed with single discharges. For the single discharge time between successive single discharges was at least 1 second. The EUT shall be exposed to at least 200 discharges, 100 each at negative and positive polarity, at a minimum of four test points. One of the test points shall be subjected to at least 50 indirect discharges to the center of the front edge of the horizontal coupling plane. The remaining three test points shall each receive at least 50 direct contact discharges.

If no direct contact test points are available, then at least 200 indirect discharges shall be applied in the indirect mode. Test shall be performed at a maximum repetition rate of one discharge per second.

Vertical Coupling Plane (VCP):

The coupling plane, of dimensions 0.5m x 0.5m, is placed parallel to, and positioned at a distance 0.1m from, the EUT, with the Discharge Electrode touching the coupling plane.

The four faces of the EUT will be performed with electrostatic discharge.

Horizontal Coupling Plane (HCP):

The coupling plane is placed under to the EUT. The generator shall be positioned vertically at a distance of 0.1m from the EUT, with the Discharge Electrode touching the coupling plane.

The four faces of the EUT will be performed with electrostatic discharge.

- b. Air discharges at insulation surfaces of the EUT.

It was at least ten single discharges with positive and negative at the same selected point.

5.3.4 DEVIATION FROM TEST STANDARD

No deviation

5.3.5 TEST SETUP

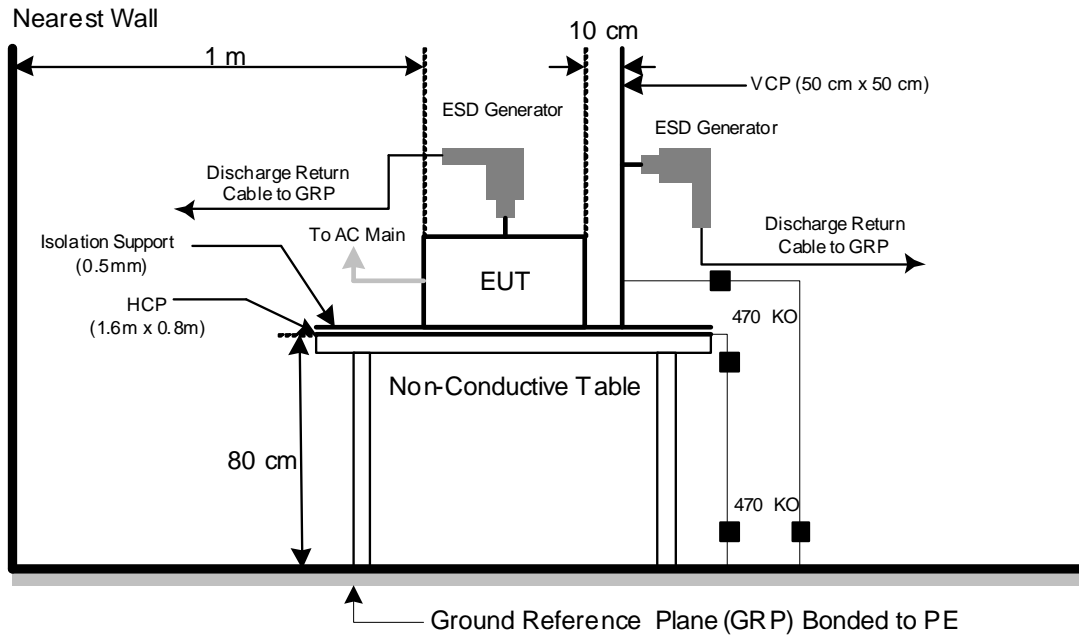

Note:

TABLE-TOP EQUIPMENT

The configuration consisted of a wooden table 0.8 meters high standing on the Ground Reference Plane. The GRP consisted of a sheet of aluminum at least 0.25mm thick, and 2.5 meters square connected to the protective grounding system. A Horizontal Coupling Plane (1.6m x 0.8m) was placed on the table and attached to the GRP by means of a cable with 940k total impedance. The equipment under test was installed in a representative system as described in EN 61000-4-2, and its cables were placed on the HCP and isolated by an insulating support of 0.5mm thickness. A distance of 1-meter minimum was provided between the EUT and the walls of the laboratory and any other metallic structure.

FLOOR-STANDING EQUIPMENT

The equipment under test was installed in a representative system as described in EN 61000-4-2, and its cables were isolated from the Ground Reference Plane by an insulating support of 0.1-meter thickness. The GRP consisted of a sheet of aluminum that is at least 0.25mm thick, and 2.5meters square connected to the protective grounding system and extended at least 0.5 meters from the EUT on all sides.

5.3.6 TEST RESULTS

EUT	IP Phone	Model Name	X4
Temperature	25°C	Relative Humidity	46%
Test Voltage	AC 230V/50Hz	Pressure	1010hPa
Test Mode	Handfree,Handset,Earphone		

Mode	Air Discharge								Contact Discharge					
	2kV		4kV		8kV		- kV		2kV		4kV		- kV	
Location	P	N	P	N	P	N	P	N	P	N	P	N	P	N
1	A	A	A	A	A	A	-	-	A	A	A	A	-	-
2	A	A	A	A	A	A	-	-					-	-
3	A	A	A	A	A	A	-	-	-	-	-	-	-	-
4	A	A	A	A	A	A	-	-	-	-	-	-	-	-
5	A	A	A	A	A	A	-	-	-	-	-	-	-	-
6	A	A	A	A	A	A	-	-	-	-	-	-	-	-
7	A	A	A	A	A	A	-	-	-	-	-	-	-	-
8	A	A	A	A	A	A	-	-	-	-	-	-	-	-
Criteria	B						-		B				-	
Result	A						-		A				-	
Judgment	PASS						-		PASS				-	

Mode	HCP Contact Discharge						VCP Contact Discharge							
	2kV		4kV		- kV		2kV		4kV		- kV			
Location	P	N	P	N	P	N	P	N	P	N	P	N		
1	A	A	A	A	-	-	A	A	A	A	-	-		
2	A	A	A	A	-	-	A	A	A	A	-	-		
3	A	A	A	A	-	-	A	A	A	A	-	-		
4	A	A	A	A	-	-	A	A	A	A	-	-		
Criteria	B						-		B				-	
Result	A						-		A				-	
Judgment	PASS						-		PASS				-	

Note:

- 1) P/N denotes the Positive/Negative polarity of the output voltage.
- 2) Test condition:
 Direct/Indirect(HCP/VCP) discharges: Minimum 50 times (Positive/Negative) at eachpoint.
 Air discharges: Minimum 20 times (Positive/Negative) at each point.
- 3) Test location(s) in which discharge (Air and contact discharge) to be applied illustrated by photos shown in next page(s)
- 4) The Indirect (HCP/VCP) discharges description of test point as following:
 1.left side; 2.right side; 3.front side; 4.rear side.
- 5) N/A - denotes test is not applicable in this test report
- 6) Criterion A: No observation of any performance degradation.
- 7) Criterion B: Some degradation of performance is observed but the equipment continues to operate as intended.
- 8) Criterion C: Loss of functionality, but self-recoverable by user, without loss of information or settings.

PHOTO(S) SHOWN THE LOCATION(S) OF ESD EVALUATED

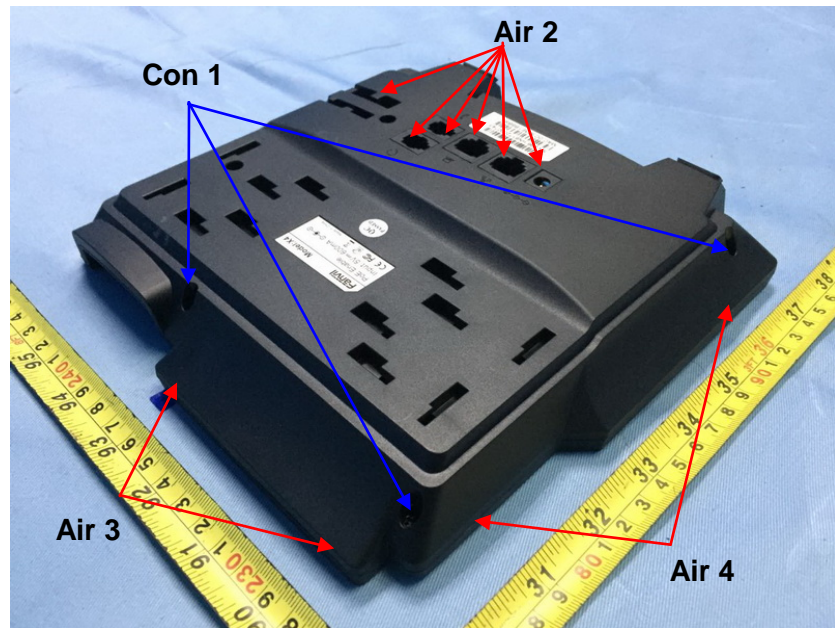
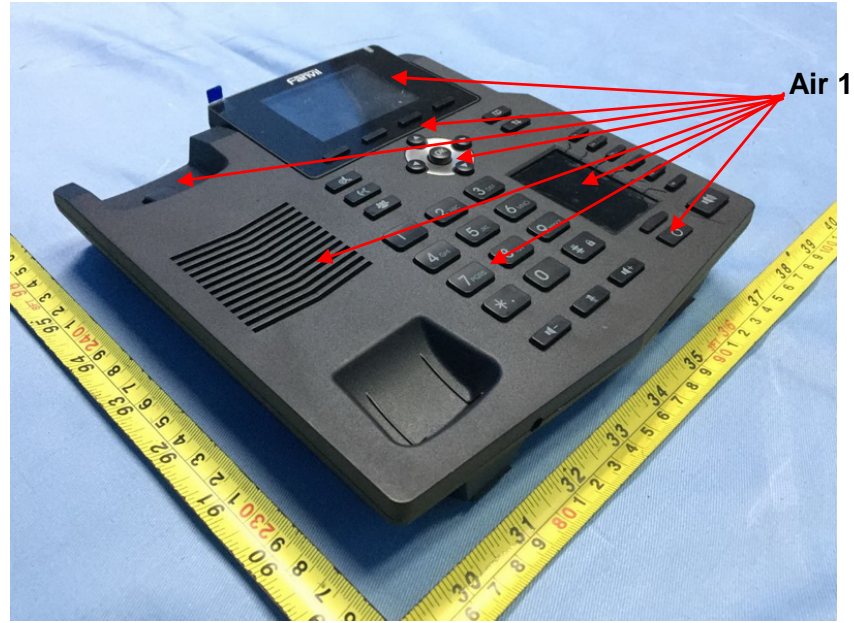

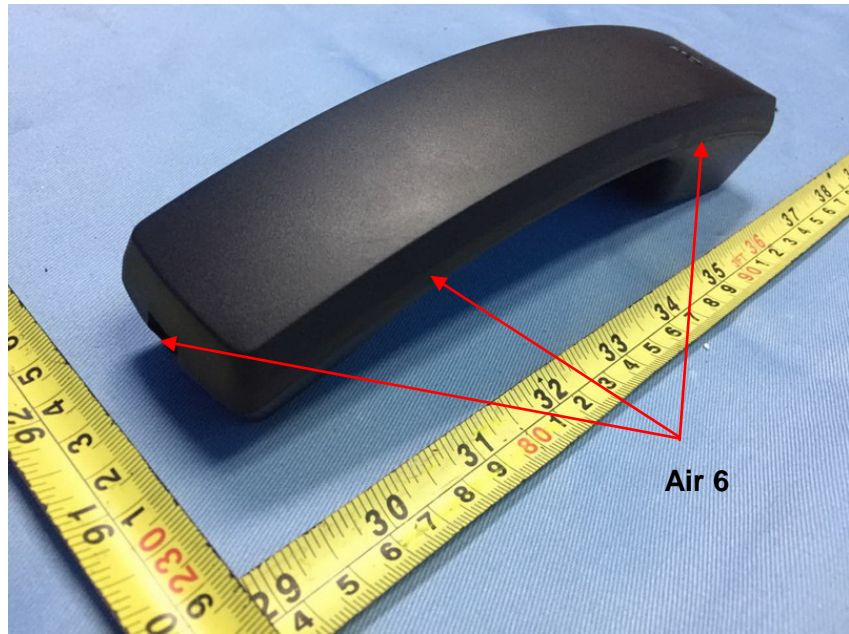
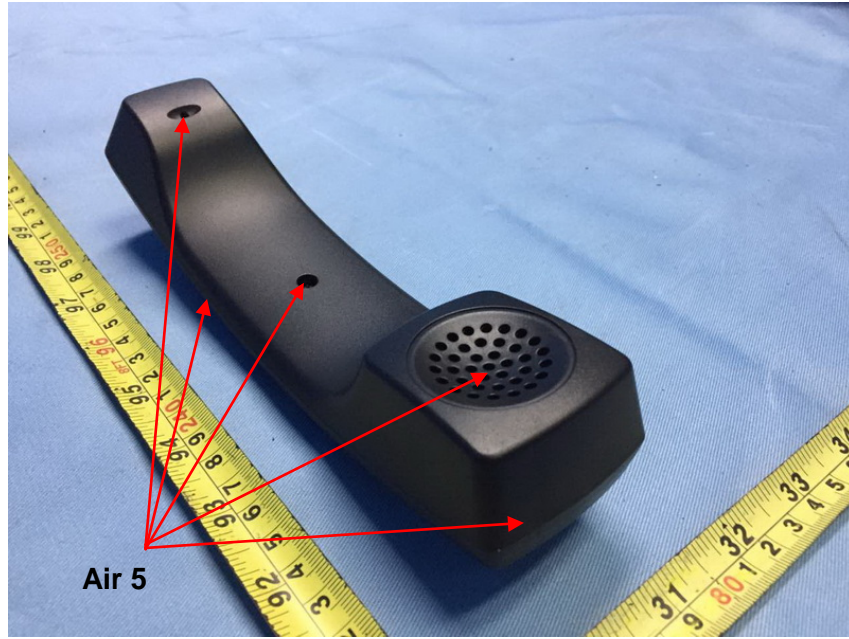

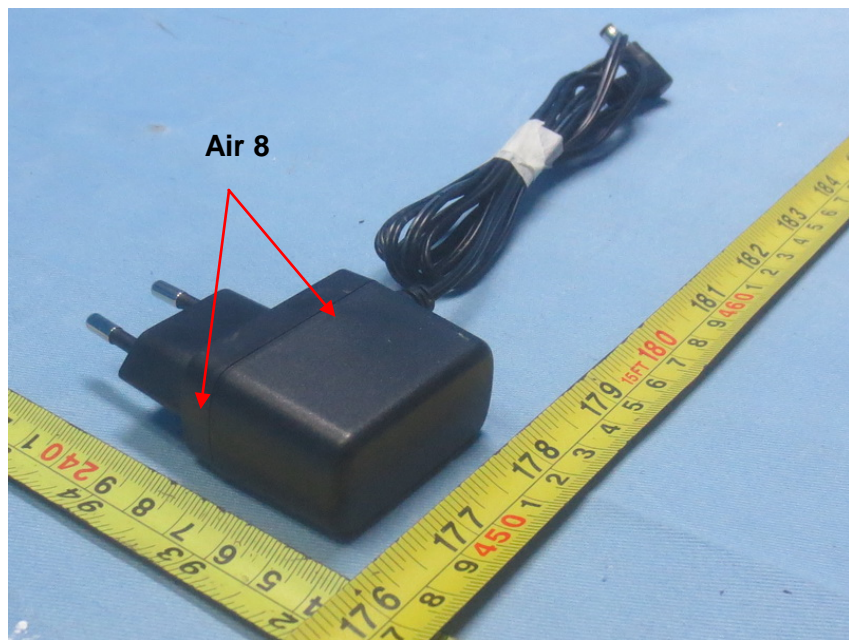
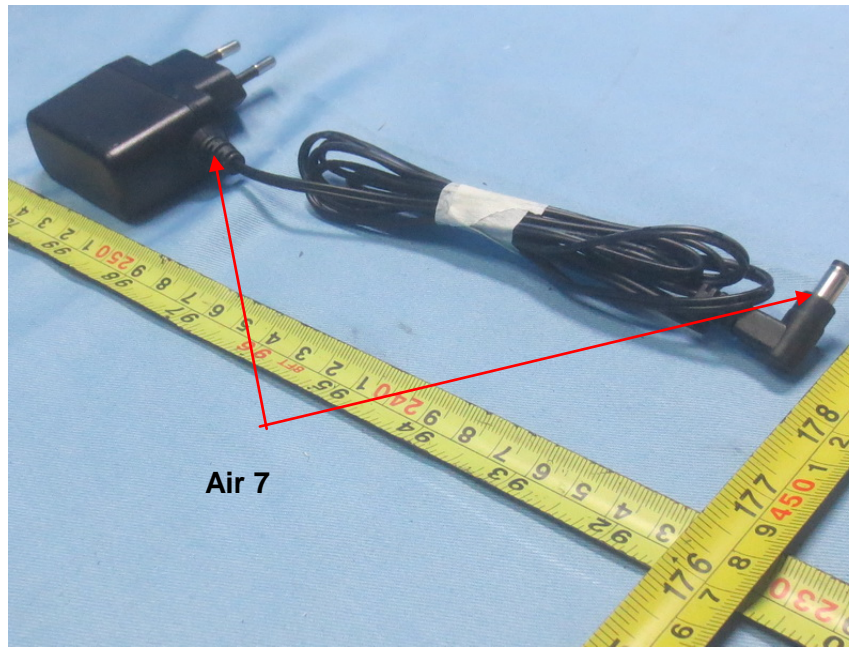

5.4 RADIATED, RADIO-FREQUENCY, ELECTROMAGNETIC FIELD IMMUNITY TEST (RS)

5.4.1 TEST SPECIFICATION

Basic Standard	EN 61000-4-3
Required Performance	A
Frequency Range	80 MHz - 1000 MHz
Field Strength	3 V/m(unmodulated, r.m.s)
Modulation	1 kHz Sine Wave, 80%, AM Modulation
Frequency Step	1% of fundamental
Polarity of Antenna	Horizontal and Vertical
Test Distance	3 m
Antenna Height	1.5 m
Dwell Time	at least 3 seconds

5.4.2 MEASUREMENT INSTRUMENTS

Item	Kind of Equipment	Manufacturer	Type No.	Serial No.	Calibrated until
1	Antenna	ETS	3142C	00047662	Mar. 26, 2018
2	Digital Signal Generator	HP	ESG-D300 0A	US36260188	Mar. 26, 2018
3	Power amplifier	MILMEGA	80RF1000- 250	1064833	Nov. 02, 2017
4	Measurement Software	TOYO	IM5/R Ver 3.8.050	N/A	N/A

Remark: "N/A" denotes no model name, no serial No. or no calibration specified.

All calibration period of equipment list is one year.

5.4.3 TEST PROCEDURE

The EUT and support equipment, which are placed on a table that is 0.8 meter above ground and the testing was performed in a fully-anechoic chamber.

The testing distance from antenna to the EUT was 3 meters.

The other condition as following manner:

- a. The field strength level was 3 V/m(unmodulated, r.m.s).
- b. The frequency range is swept from 80 MHz to 1000 MHz, with the signal 80%amplitude modulated with a 1 kHz sine wave. The rate of sweep did not exceed 1.5×10^{-3} decade/s. Where the frequency range is swept incrementally, the step size was 1% of fundamental.
- c. The dwell time at each frequency shall be not less than the time necessary for the EUT to be able to respond.
- d. The test was performed with the EUT exposed to both vertically and horizontally polarized fields on each of the four sides.

5.4.4 DEVIATION FROM TEST STANDARD

No deviation

5.4.5 TEST SETUP

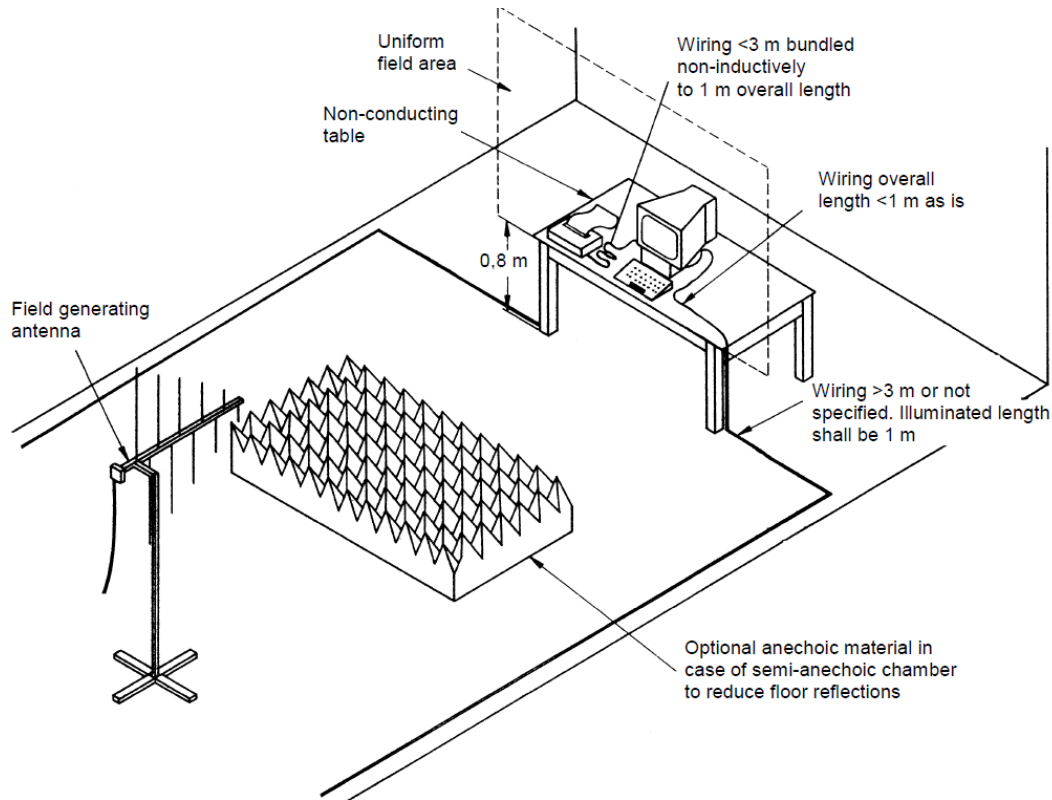

Note:

TABLE-TOP EQUIPMENT

The EUT installed in a representative system as described in EN 61000-4-3 was placed on a non-conductive table 0.8 meters in height. The system under test was connected to the power and signal wire according to relevant installation instructions.

FLOOR-STANDING EQUIPMENT

The EUT installed in a representative system as described in EN 61000-4-3 was placed on a non-conductive wood support 0.1 meters in height. The system under test was connected to the power and signal wire according to relevant installation instructions.

5.4.6 TEST RESULTS

EUT	IP Phone	Model Name	X4
Temperature	25°C	Relative Humidity	55%
Test Voltage	AC 230V/50Hz		
Test Mode	Handfree,Handset,Earphone		

Frequency Range (MHz)	RF Field Position	R.F. Field Strength	Azimuth	Criterion	Result	Judgment
80 - 1000	H / V	3V (unmodulated, r.m.s) AM Modulated 1000Hz, 80%	0	A	A	PASS
			90			
			180			
			270			

Note:

- 1) P/N denotes the Positive/Negative polarity of the output voltage.
- 2) N/A - denotes test is not applicable in this test report.
- 3) Criterion A: No observation of any performance degradation.
- 4) Criterion B: Some degradation of performance is observed but the equipment continues to operate as intended.
- 5) Criterion C: Loss of functionality, but self-recoverable by user, without loss of information or settings.

5.5 ELECTRICAL FAST TRANSIENT/BURST IMMUNITY TEST (EFT/BURST)

5.5.1 TEST SPECIFICATION

Basic Standard	EN 61000-4-4
Required Performance	B
Test Voltage	Power Line: ± 1 kV Signal/Control Line: ± 0.5 kV
Polarity	Positive & Negative
Impulse Frequency	5 kHz: except for xDSL equipment 100 kHz: only for single lines of xDSL equipment.
Impulse Wave shape	5/50 ns
Burst Duration	15 ms
Burst Period	300 ms
Test Duration	Not less than 1 min.

5.5.2 MEASUREMENT INSTRUMENTS

Item	Kind of Equipment	Manufacturer	Type No.	Serial No.	Calibrated until
1	Capacitor Clamp	Thermo KeyTek	CCL	0502215	Feb. 24, 2018
2	THE MODULAR SOLUTION FOR 6 KV APPLICATIONS	Teseq	NSG 3060	1423	Sep. 04, 2017
3	Measurement Software	Teseq	Win 3000 Version 1.2.0	N/A	N/A

Remark: "N/A" denotes no model name, no serial No. or no calibration specified.

All calibration period of equipment list is one year.

5.5.3 TEST PROCEDURE

The EUT and support equipment(s) are placed on a table that is 0.8 meter high above a metal ground plane and should be located 0.1 m \pm 0.01m high above the Ground Reference Plane (1m*1m min. and 0.65mm thick min).

The other condition as following manner:

- The length of power cord between the coupling device and the EUT should not exceed 1 meter.
- Both positive and negative polarity discharges were applied.
- The duration time of each test sequential was 1 minute

5.5.4 DEVIATION FROM TEST STANDARD

No deviation

5.5.5 TEST SETUP

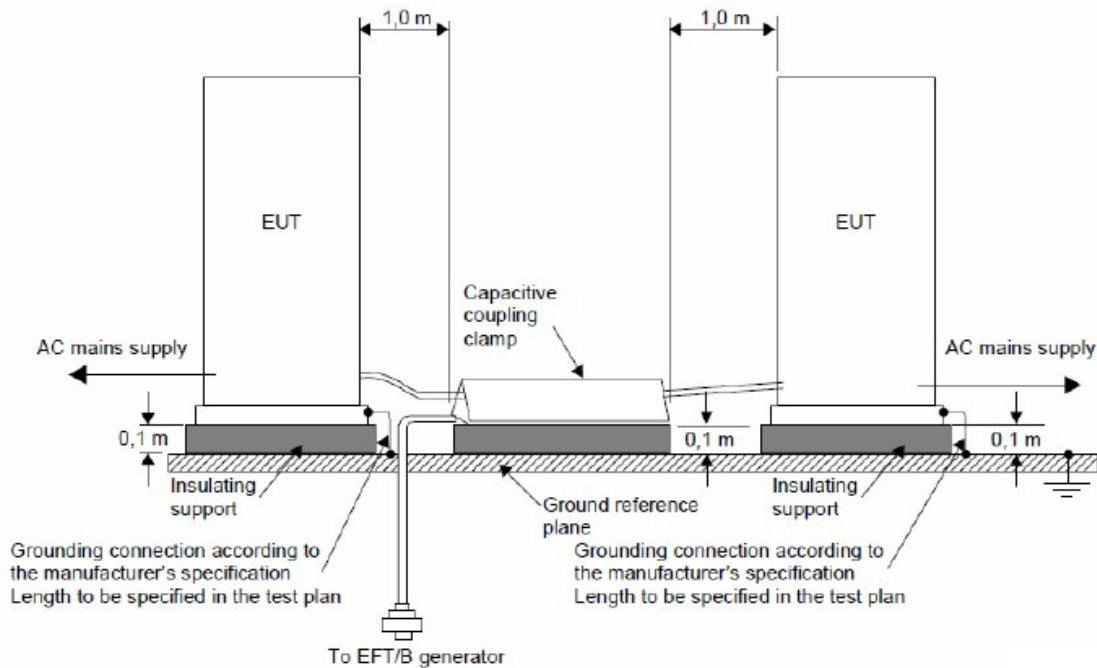
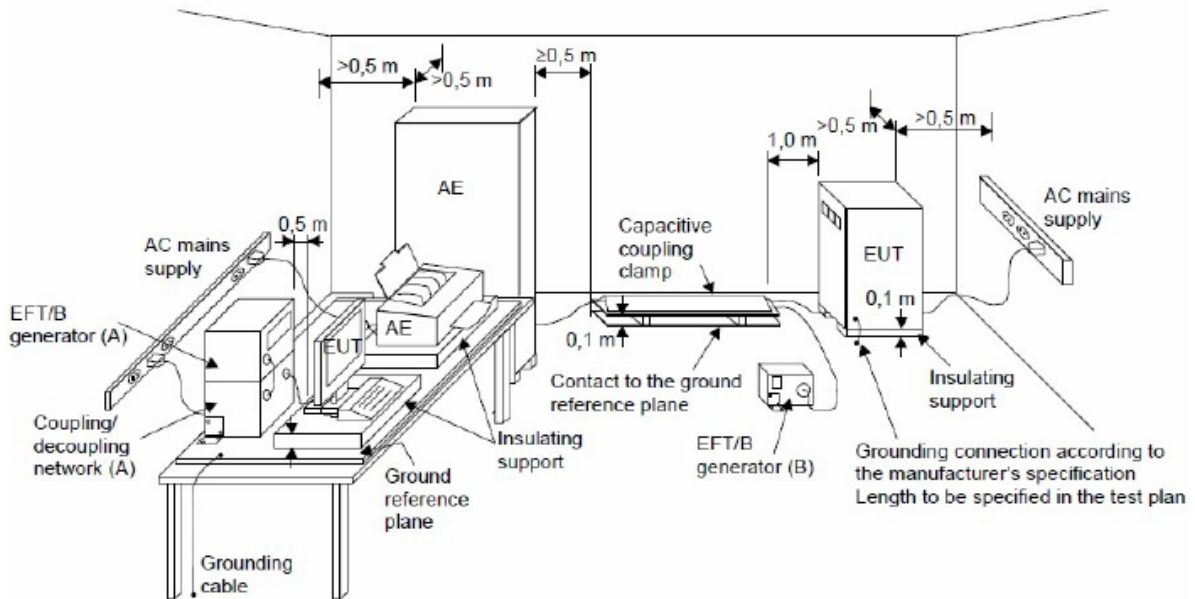

Note:

TABLE-TOP EQUIPMENT

The configuration consisted of a wooden table (0.8m high) standing on the Ground Reference Plane and should be located 0.1 m+/- 0.01m above the Ground Reference Plane. The GRP consisted of a sheet of aluminum (at least 0.25mm thick and 2.5m square) connected to the protective grounding system. A minimum distance of 0.5m was provided between the EUT and the walls of the laboratory or any other metallic structure.

FLOOR-STANDING EQUIPMENT

The EUT installed in a representative system as described in EN 61000-4-4 and its cables were isolated from the Ground Reference Plane by an insulating support that is 0.1-meter thick. The GRP consisted of a sheet of aluminum (at least 0.25mm thick and 2.5m square) connected to the protective grounding system.

5.5.6 TEST RESULTS

EUT	IP Phone	Model Name	X4
Temperature	25°C	Relative Humidity	54%
Test Voltage	AC 230V/50Hz		
Test Mode	Handfree,Handset,Earphone		

EUT Ports Tested		Polarity	Repetition Frequency	Test Level	Criterion	Result	Judgment
				1kV			
AC Power Port	Line (L)	+	5 kHz	A	B	A	PASS
		-	5 kHz	A			
	Neutral (N)	+	5 kHz	A	B	A	PASS
		-	5 kHz	A			
	Ground (PE)	+	5 kHz	-	B	N/A	N/A
		-	5 kHz	-			

EUT Ports Tested		Polarity	Repetition Frequency	Test Level	Criterion	Result	Judgment
				0.5 kV			
Signal Port	PC	+	5 kHz	B	B	B	PASS
		-	5 kHz	B			
Signal Port	Internet	+	5 kHz	B	B	B	PASS
		-	5 kHz	B			

Note:

- 1) P/N denotes the Positive/Negative polarity of the output voltage.
- 2) N/A - denotes test is not applicable in this test report
- 3) Criterion A: No observation of any performance degradation.
- 4) Criterion B: Some degradation of performance is observed but the equipment continues to operate as intended.
- 5) Criterion C: Loss of functionality, but self-recoverable by user, without loss of information or settings.

5.6 SURGE IMMUNITY TEST

5.6.1 TEST SPECIFICATION

Basic Standard	EN 61000-4-5
Required Performance	B
Wave-Shape	Combination Wave for power lines 1.2/50 us Open Circuit Voltage 8 /20 us Short Circuit Current
Test Voltage	Power Line: ± 0.5 kV, ± 1 kV
Surge Input/Output	L-N
Generator Source Impedance	2 ohm between networks 12 ohm between network and ground
Polarity	Positive/Negative
Phase Angle:	AC Port: $0^\circ/90^\circ/180^\circ/270^\circ$
Pulse Repetition Rate	1 time / min. (maximum)
Number of Tests	5 positive and 5 negative at selected points

5.6.2 MEASUREMENT INSTRUMENTS

Item	Kind of Equipment	Manufacturer	Type No.	Serial No.	Calibrated until
1	System mainframe	Schaffner	NSG 2050	200729-619 LU	Sep. 04, 2017
2	Signal & Data line coupling network	TEseq	CDN 118	24103	May. 24, 2017
3	THE MODULAR SOLUTION FOR 6 KV APPLICATIONS	Teseq	NSG 3060	1423	Sep. 04, 2017
4	Measurement Software	Teseq	Win 3000 Version 1.2.0	N/A	N/A
5	Measurement Software	Schaffner	Win 2000 Version V7.10	N/A	N/A

Remark: "N/A" denotes no model name, no serial No. or no calibration specified.
All calibration period of equipment list is one year.

5.6.3 TEST PROCEDURE

a. For EUT power supply:

The surge is to be applied to the EUT power supply terminals via the capacitive coupling network. Decoupling networks are required in order to avoid possible adverse effects on equipment not under test that may be powered by the same lines, and to provide sufficient decoupling impedance to the surge wave. The power cord between the EUT and the coupling/decoupling networks shall be 2meters in length (or shorter).

b. For test applied to unshielded unsymmetrically operated interconnection lines of EUT :

The surge is applied to the lines via the capacitive coupling. The coupling /decoupling networks shall not influence the specified functional conditions of the EUT. The interconnection line between the EUT and the coupling/decoupling networks shall be 2 meters in length (or shorter).

c. For test applied to unshielded symmetrically operated interconnection /telecommunication lines of EUT :

The surge is applied to the lines via gas arrestors coupling. Test levels below the ignition point of the coupling arrester cannot be specified. The interconnection line between the EUT and the coupling/decoupling networks shall be 2 meters in length (or shorter).

5.6.4 DEVIATION FROM TEST STANDARD

No deviation

5.6.5 TEST SETUP

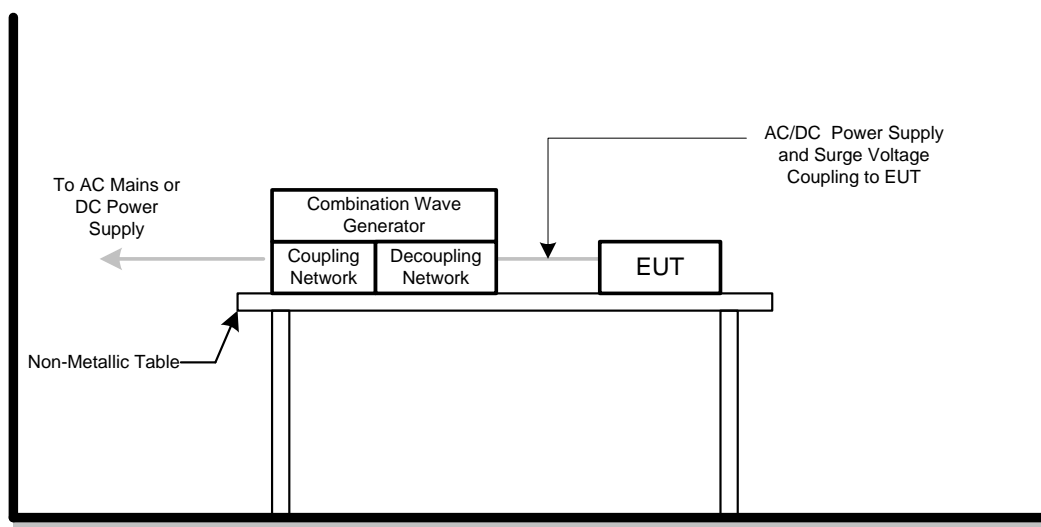

5.6.6 TEST RESULTS

EUT	IP Phone	Model Name	X4
Temperature	25°C	Relative Humidity	55%
Test Voltage	AC 230V/50Hz		
Test Mode	Handfree, Handset, Earphone		

Wave Form	EUT Ports Tested	1.2/50(8/20)Tr/Thps						Criterion	Result	Judgment
		Polarity	Phase	Voltage						
				0.5kV	1kV	-- kV	-- kV			
AC	L – N (2 ohm)	+/-	0°	A	A	-	-	B	A	PASS
		+/-	90°	A	A	-	-			
		+/-	180°	A	A	-	-			
		+/-	270°	A	A	-	-			

Note:

- 1) Polarity and Numbers of Impulses: 5 Pst / Ngst at each tested mode
- 2) N/A - denotes test is not applicable in this Test Report
- 3) Criterion A: No observation of any performance degradation.
- 4) Criterion B: Some degradation of performance is observed but the equipment continues to operate as intended.
- 5) Criterion C: Loss of functionality, but self-recoverable by user, without loss of information or settings.

5.7 IMMUNITY TO CONDUCTED DISTURBANCES, INDUCED BY RADIO-FREQUENCY FIELDS TEST (CS)

5.7.1 TEST SPECIFICATION

Basic Standard	EN 61000-4-6
Required Performance	A
Frequency Range	0.15 MHz - 80 MHz
Field Strength	3 V (unmodulated, r.m.s.)
Modulation	1 kHz Sine Wave, 80%, AM Modulation
Frequency Step	1% of fundamental
Dwell Time	at least 3 seconds

5.7.2 MEASUREMENT INSTRUMENTS

Item	Kind of Equipment	Manufacturer	Type No.	Serial No.	Calibrated until
1	Measurement Software	TOYO	IM5/C Ver 3.7.028	N/A	N/A
2	Power CDN	FCC	FCC-801-M2/M3-16A	100270	Mar. 26, 2018
3	Power CDN	FCC	FCC-801-M2/M3-16A	100271	Mar. 26, 2018
4	Power Amplifier	Teseq	CBA230M-080	T43748	Mar. 26, 2018
5	Signal Generator	HP	8648A	3636A02964	Mar. 26, 2018
6	Measurement Software	Farad	EZ-CS?(V2 .0.1.2)	N/A	N/A
7	Signal Line CDN	FCC	F-090407-1004-1	100518	Mar. 26, 2018
8	TEST SYSTEM FOR CONDUCTED AND RADIATED IMMUNITY	TESEQ	NSG 4070B	37513	Sep. 04, 2017

Remark: "N/A" denotes no model name, no serial No. or no calibration specified.

All calibration period of equipment list is one year.

5.7.3 TEST PROCEDURE

The EUT and support equipment, are placed on a table that is 0.8 meter above a metal ground plane measured 1m*1m min. and 0.65mm thick min.

The other condition as following manner:

- a. The field strength level was 3 V (unmodulated, r.m.s.)
- b. The frequency range is swept from 150 kHz to 80 MHz, with the signal 80%amplitude modulated with a 1 kHz sine wave. The rate of sweep did not exceed 1.5×10^{-3} decade/s. Where the frequency range is swept incrementally, the step size was 1% of fundamental.
- c. The dwell time at each frequency shall be not less than the time necessary for the EUT to be able to respond.

5.7.4 DEVIATION FROM TEST STANDARD

No deviation

5.7.5 TEST SETUP

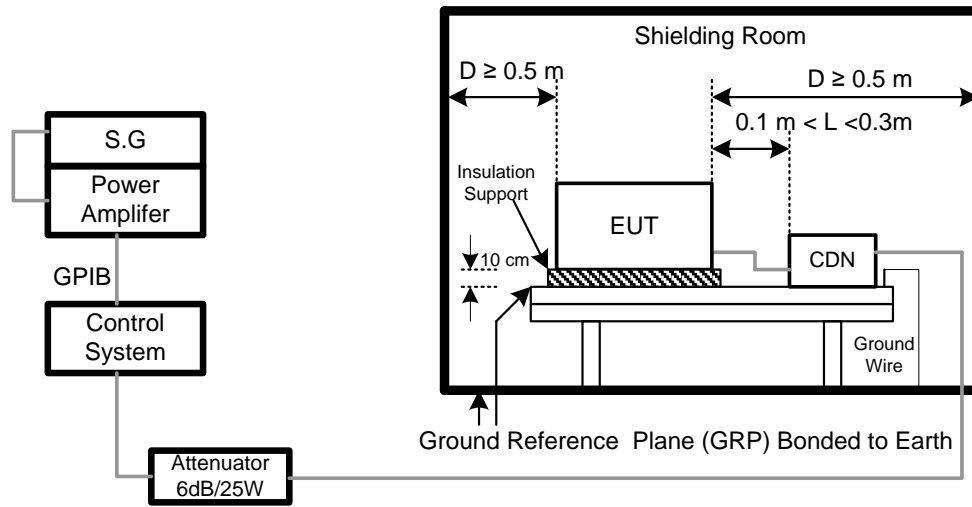

NOTE:

FLOOR-STANDING EQUIPMENT

The equipment to be tested is placed on an insulating support of 0.1 meters height above a ground reference plane. All relevant cables shall be provided with the appropriate coupling and decoupling devices at a distance between 0.1 meters and 0.3 meters from the projected geometry of the EUT on the ground reference plane.

5.7.6 TEST RESULTS

EUT	IP Phone	Model Name	X4
Temperature	25°C	Relative Humidity	55%
Test Voltage	AC 230V/50Hz		
Test Mode	Handfree,Handset,Earphone		

Test Ports (Mode)	Freq.Range (MHz)	Field Strength	Criteria	Results	Judgment
Input/ Output AC.PowerPort	0.15 ---80	3V(unmodulated, r.m.s) AM Modulated 1000Hz, 80%	A	A	PASS
Input/ Output DC. PowerPort	0.15 --- 80		A	N/A	N/A
Signal Line (PC Port)	0.15 --- 80		A	A	PASS
Signal Line (Internet Port)	0.15 --- 80		A	A	PASS

Note:

- 1). N/A - denotes test is not applicable in this test report.
- 2) Criterion A: No observation of any performance degradation.
- 3) Criterion B: Some degradation of performance is observed but the equipment continues to operate as intended.
- 4) Criterion C: Loss of functionality, but self-recoverable by user, without loss of information or settings.

5.8 POWER FREQUENCY MAGNETIC FIELD IMMUNITY TEST (PFMF)

5.8.1 TEST SPECIFICATION

Basic Standard	EN 61000-4-8
Required Performance	A
Frequency Range	50/60 Hz
Field Strength	1 A/m
Observation Time	1 minute
Inductance Coil	Rectangular type, 1mx1m

5.8.2 MEASUREMENT INSTRUMENTS

Item	Kind of Equipment	Manufacturer	Type No.	Serial No.	Calibrated until
1	Magnetic Field test Generator	FCC	F-1000-4-8-G-125A	04032	Mar. 26, 2018
2	Magnetic Field immunity loop	Thermo KeyTek	F-1000-4-8/9/10-L-1M	04024	Mar. 26, 2018

Remark: "N/A" denotes no model name, no serial No. or no calibration specified.
All calibration period of equipment list is one year.

5.8.3 TEST PROCEDURE

The EUT and support equipment, are placed on a table that is 0.8 meter above a metal ground plane measured 1m*1m min. and 0.65mm thick min.

The other condition as following manner:

- a. The equipment cabinets shall be connected to the safety earth directly on the GRP via the earth terminal of the EUT.
- b. The cables supplied or recommended by the equipment manufacturer shall be used. 1 meter of all cables used shall be exposed to the magnetic field.

5.8.4 DEVIATION FROM TEST STANDARD

No deviation

5.8.5 TEST SETUP

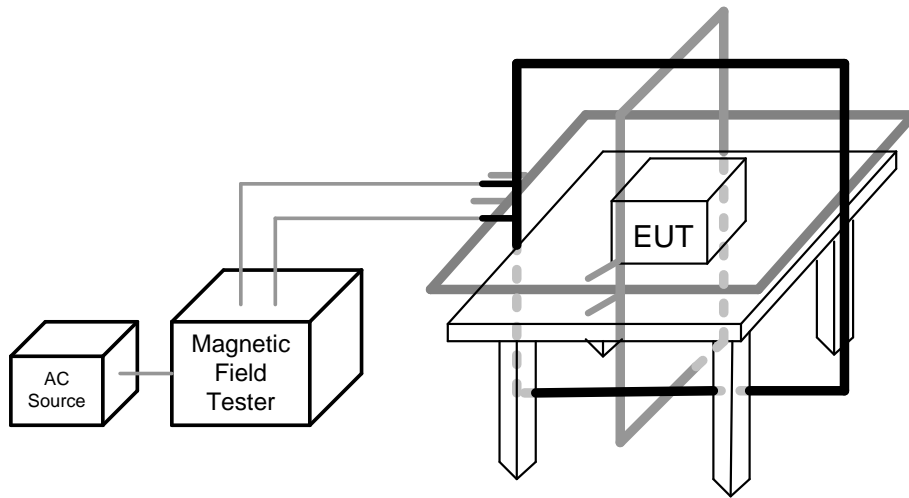

Note:

TABLE-TOP EQUIPMENT

The equipment shall be subjected to the test magnetic field by using the induction coil of standard dimension (1 m x 1 m). The induction coil shall then be rotated by 90 degrees in order to expose the EUT to the test field with different orientations.

FLOOR-STANDING EQUIPMENT

The equipment shall be subjected to the test magnetic field by using induction coils of suitable dimensions. The test shall be repeated by moving and shifting the induction coils, in order to test the whole volume of the EUT for each orthogonal direction. The test shall be repeated with the coil shifted to different positions along the side of the EUT, in steps corresponding to 50 percent of the shortest side of the coil. The induction coil shall then be rotated by 90 degrees in order to expose the EUT to the test field with different orientations.

5.8.6 TEST RESULTS

EUT	IP Phone	Model Name	X4
Temperature	25°C	Relative Humidity	56%
Test Voltage	AC 230V/50Hz		
Test Mode	Handfree, Handset, Earphone		

50Hz

Test Mode	Test Level	Antenna aspect	Duration (s)	Criteria	Results	Judgment
Enclosure	1 A/m	X	60	A	A	PASS
Enclosure	1 A/m	Y	60	A	A	PASS
Enclosure	1 A/m	Z	60	A	A	PASS

60Hz

Test Mode	Test Level	Antenna aspect	Duration (s)	Criteria	Results	Judgment
Enclosure	1 A/m	X	60	A	A	PASS
Enclosure	1 A/m	Y	60	A	A	PASS
Enclosure	1 A/m	Z	60	A	A	PASS

Note:

- 1). N/A - denotes test is not applicable in this test report.
- 2) Criterion A: No observation of any performance degradation.
- 3) Criterion B: Some degradation of performance is observed but the equipment continues to operate as intended.
- 4) Criterion C: Loss of functionality, but self-recoverable by user, without loss of information or settings.

5.9 VOLTAGE DIPS, SHORT INTERRUPTIONS AND VOLTAGE VARIATIONS IMMUNITY TEST

5.9.1 TEST SPECIFICATION

Basic Standard	EN 61000-4-11
Required Performance	B (For >95% Voltage Dips) C (For 30% Voltage Dips) C (For >95% Voltage Interruptions)
Test Duration Time	Minimum three test events in sequence
Interval between Event	Minimum ten seconds
Phase Angle	0°/180°
Test Cycle	3 times

5.9.2 MEASUREMENT INSTRUMENTS

Item	Kind of Equipment	Manufacturer	Type No.	Serial No.	Calibrated until
1	THE MODULAR SOLUTION FOR 6 KV APPLICATIONS	Teseq	NSG 3060	1423	Sep. 04, 2017
2	Measurement Software	Teseq	Win 3000 Version 1.2.0	N/A	N/A

Remark: "N/A" denotes no model name, no serial No. or no calibration specified.
All calibration period of equipment list is one year.

5.9.3 TEST PROCEDURE

The EUT shall be tested for each selected combination of test levels and duration with a sequence of three dips/interruptions with intervals of 10 s minimum (between each test event). Each representative mode of operation shall be tested. Abrupt changes in supply voltage shall occur at zero crossings of the voltage waveform.

5.9.4 DEVIATION FROM TEST STANDARD

No deviation

5.9.5 TEST SETUP

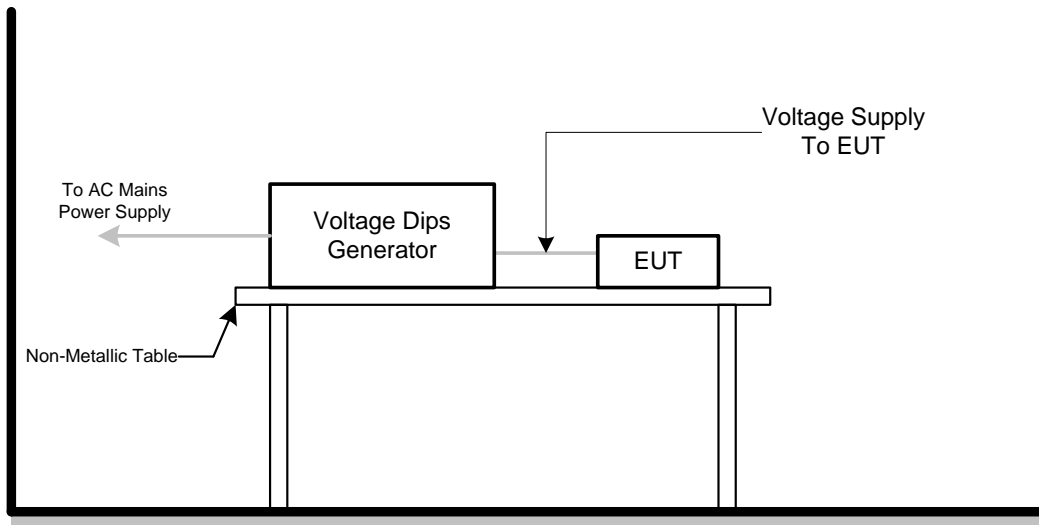

5.9.6 TEST RESULTS

EUT	IP Phone	Model Name	X4
Temperature	25°C	Relative Humidity	55%
Test Voltage	AC 230V/50Hz		
Test Mode	Handfree,Handset,Earphone		

AC 100V/50Hz				
VoltageReduction	Periods	Criteria	Results	Judgment
Voltage dip >95%	0.5	B	A	PASS
Voltage dip 30%	25	C	A	PASS
Interruption >95%	250	C	C	PASS

AC 230V/50Hz				
VoltageReduction	Periods	Criteria	Results	Judgment
Voltage dip >95%	0.5	B	A	PASS
Voltage dip 30%	25	C	A	PASS
Interruption >95%	250	C	C	PASS

AC 240V/50Hz				
VoltageReduction	Periods	Criteria	Results	Judgment
Voltage dip >95%	0.5	B	A	PASS
Voltage dip 30%	25	C	A	PASS
Interruption >95%	250	C	C	PASS

Note:

- 1). N/A - denotes test is not applicable in this test report.
- 2) Criterion A: No observation of any performance degradation.
- 3) Criterion B: Some degradation of performance is observed but the equipment continues to operate as intended.
- 4) Criterion C: Loss of functionality, but self-recoverable by user, without loss of information or settings.

6. EUT TEST PHOTO

Radiated emissions up to 1 GHz – Adapter

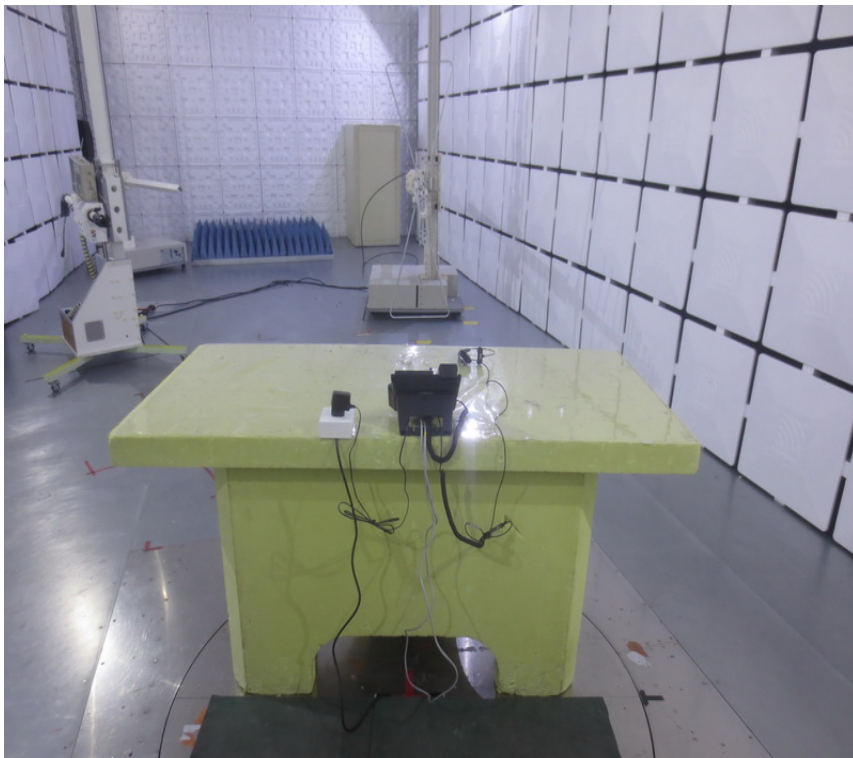
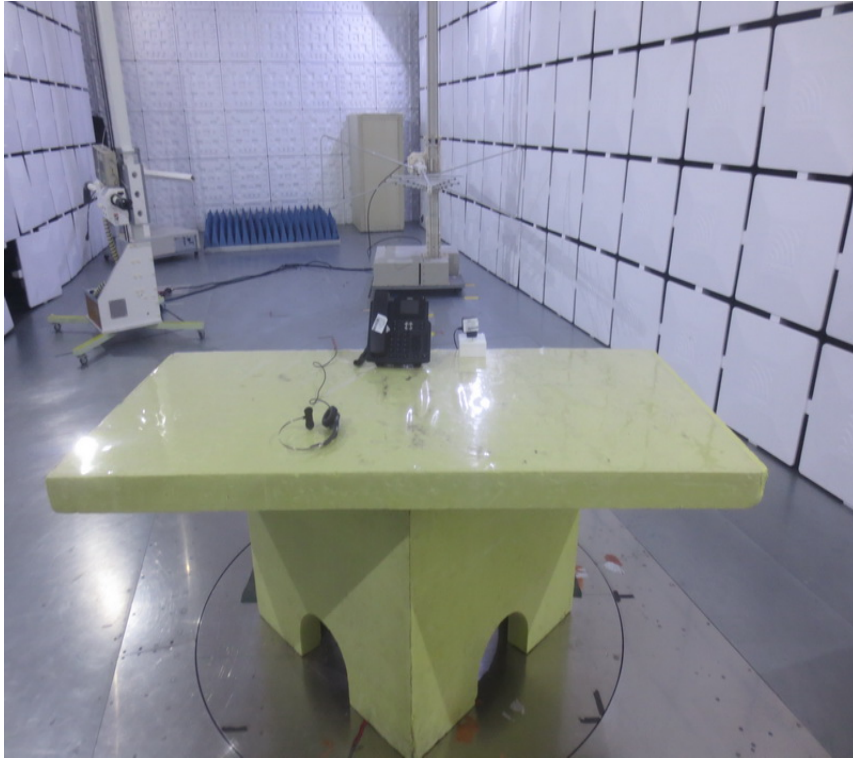

Radiated emissions up to 1 GHz – PoE

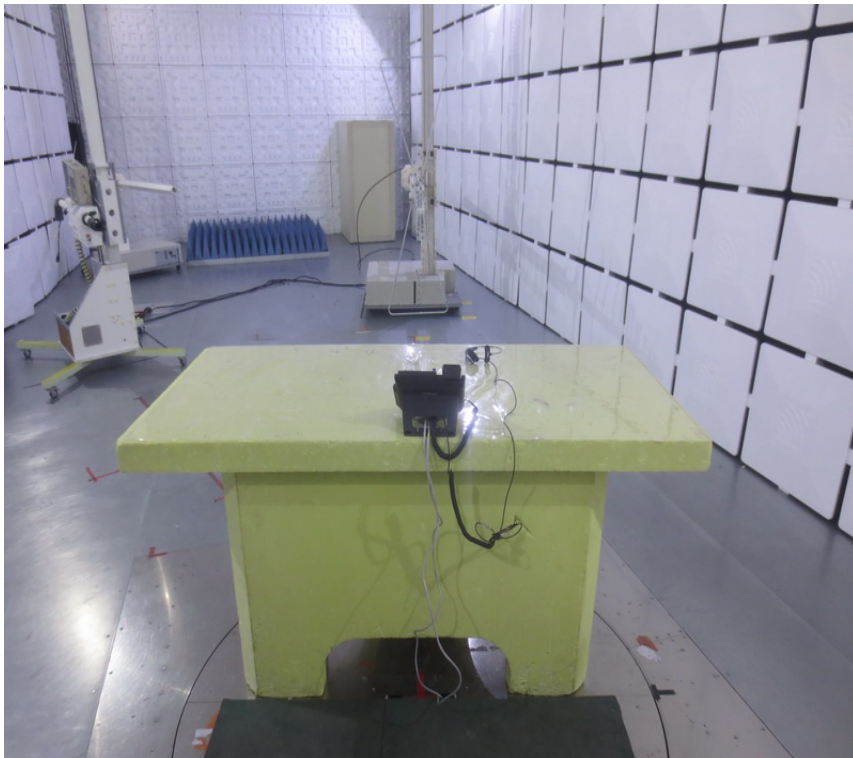
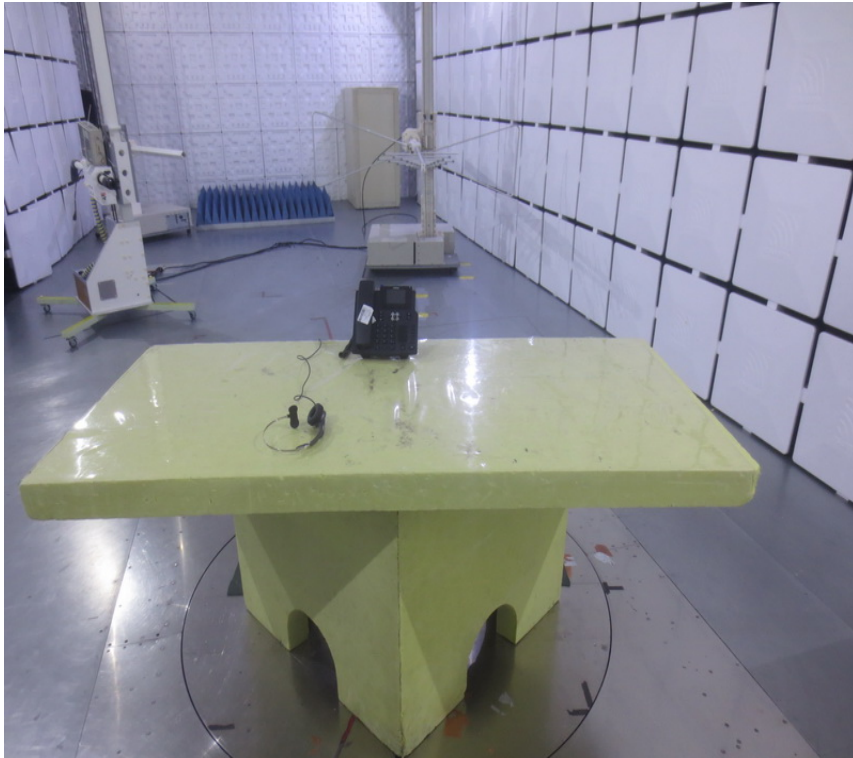

Radiated emissions above 1 GHz – Adapter

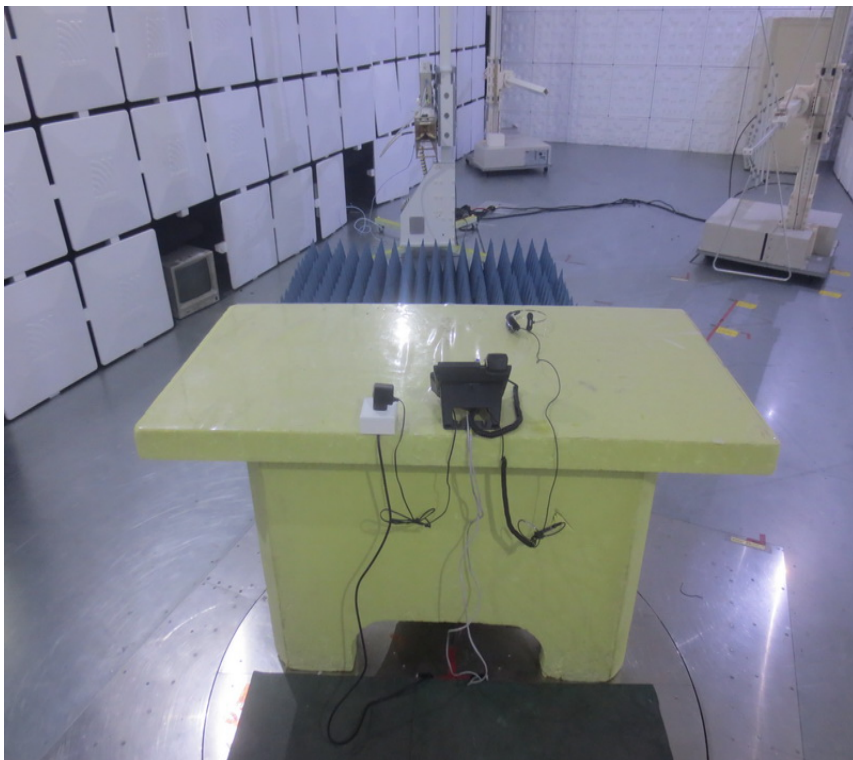
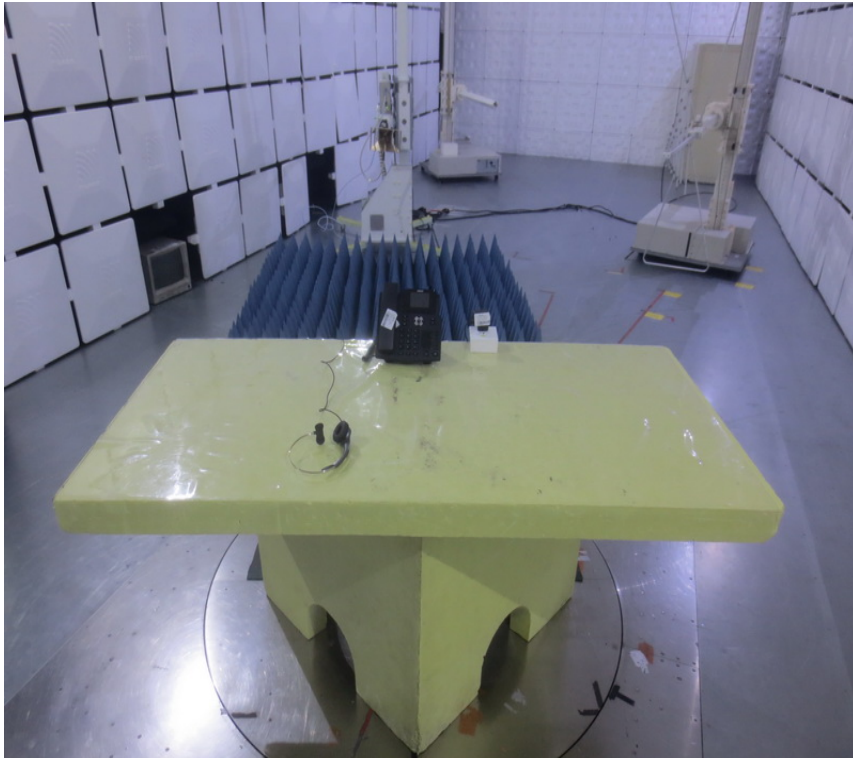

Radiated emissions above 1 GHz – PoE

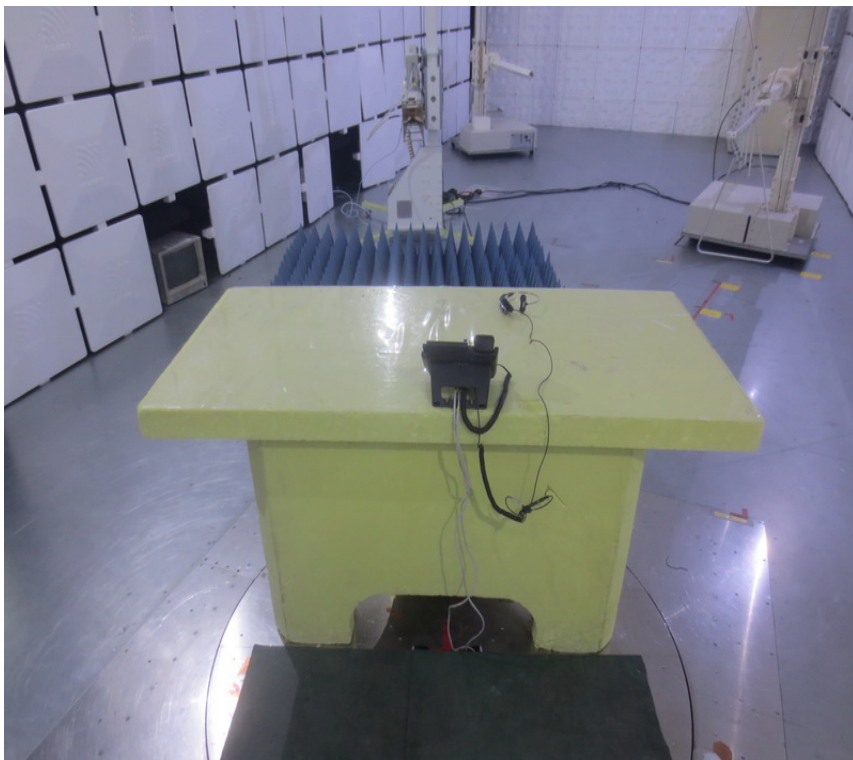
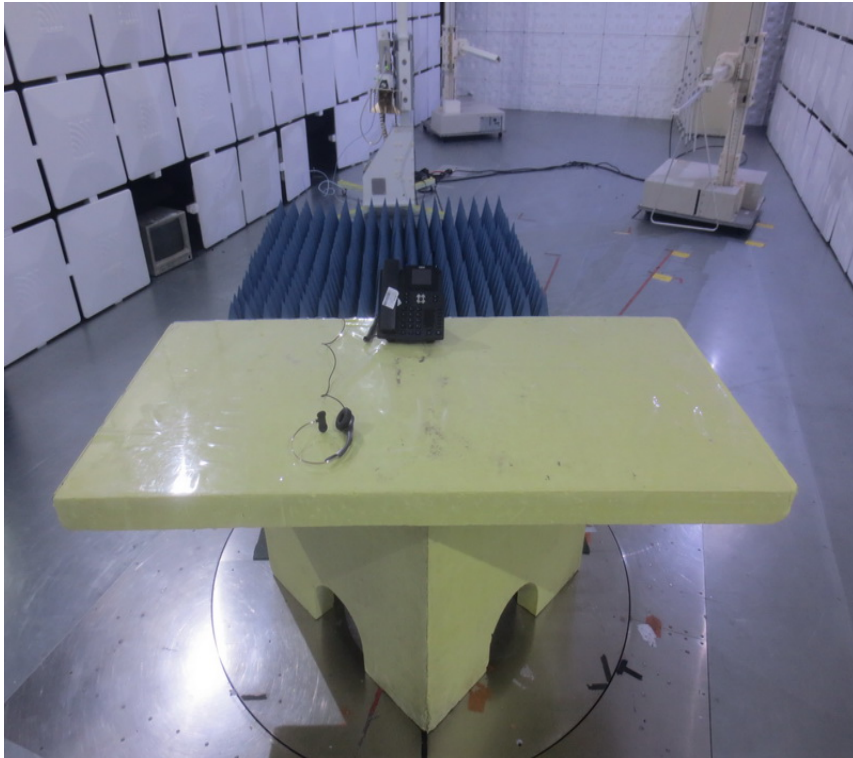

Conducted emissions AC mains power port



Asymmetric mode conducted emissions_AAN – Adapter

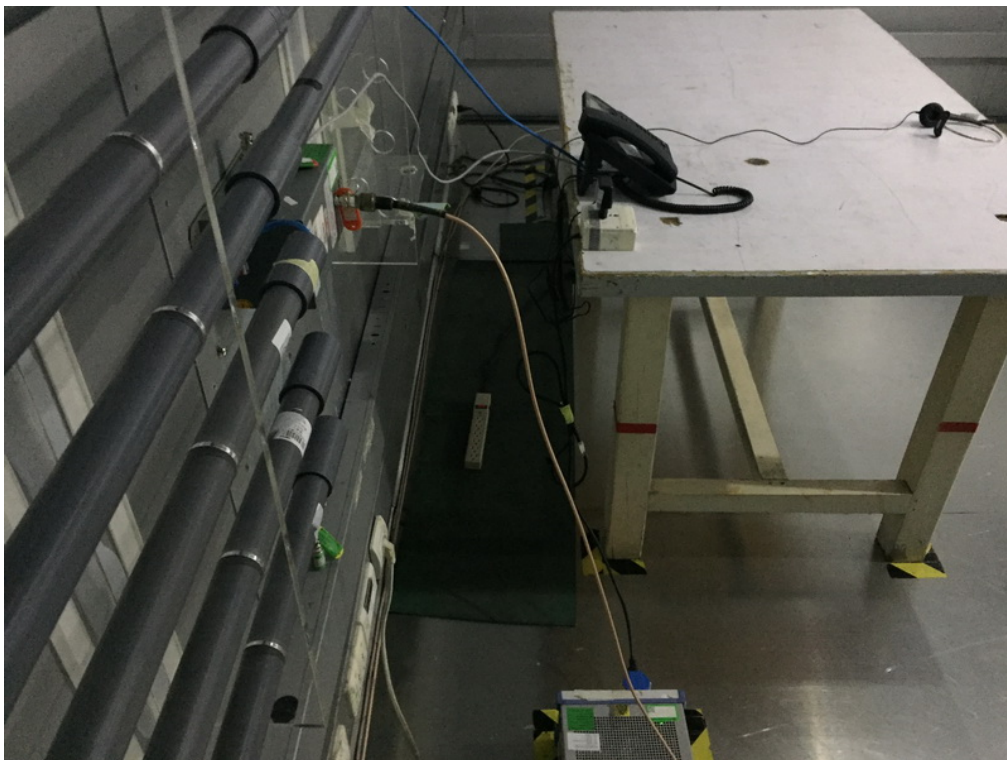

Asymmetric mode conducted emissions_AAN – PoE

