

EN 55022:2010  
 EN 55024:2010  
 EN 61000-3-2:2014  
 EN 61000-3-3:2013  
**MEASUREMENT AND TEST REPORT**

For

**Fanvil Technology Co . ,Ltd**

Level 3,Block A,Gaoxinqi Building,Anhua Industrial Park,Qianjin 1 Road,35th  
District,Bao'An,Shenzhen,518101 P.R. China

**Model: X3,X3P,X3E,X3EP**

October 14, 2015

<b>This Report Concerns:</b> <input type="checkbox"/> Original Report	<b>Equipment Type:</b> X3
<b>Test By:</b>	<u>Xiaona Deng/ <i>Xiaona Deng</i></u>
<b>Report Number:</b>	<u>HCT15JR-0996E</u>
<b>Test Date:</b>	<u>October 22~November 6, 2014</u>
<b>Reviewed By:</b>	<u>Jiankuai Li/ <i>Jiankuai Li</i></u>
<b>Approved By:</b>	<u>Owen Yang/ <i>Owen Yang</i></u>
<b>Prepared By:</b>	<b>Shenzhen Hongcai Testing Technology Co.,Ltd</b> 1st-3rd Floor,Building C,Shuanghuan Xin Yi Dai Hi-Tech Industrial Park,No.8 Baoqing Road,Baolong Industrial Zone,Longgang District, Shenzhen, Guangdong, China Tel: +86-755-86337020 Fax: +86-755-86337028

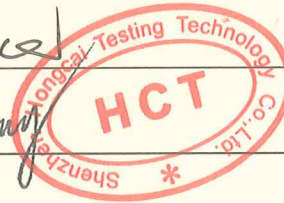

Note: This test report is limited to the above client company and the product model only. It may not be duplicated without prior written consent of Shenzhen Hongcai Testing Technology Co.,Ltd.

## TABLE OF CONTENTS

<b>1 - GENERAL INFORMATION .....</b>	<b>4</b>
1.1 PRODUCT DESCRIPTION FOR EQUIPMENT UNDER TEST (EUT) .....	4
1.2 TEST STANDARDS .....	5
1.3 TEST SUMMARY .....	5
1.4 TEST METHODOLOGY .....	6
1.5 TEST FACILITY .....	6
<b>2 - SYSTEM TEST CONFIGURATION .....</b>	<b>7</b>
2.1 JUSTIFICATION .....	7
2.2 EUT EXERCISE SOFTWARE .....	7
2.3 SPECIAL ACCESSORIES .....	7
2.4 EQUIPMENT MODIFICATIONS .....	7
2.5 TEST SETUP DIAGRAM .....	7
<b>3 - DISTURBANCE VOLTAGE AT THE MAINS TERMINALS .....</b>	<b>8</b>
3.1 MEASUREMENT UNCERTAINTY .....	8
3.2 LIMIT OF DISTURBANCE VOLTAGE AT THE MAINS TERMINALS (CLASS B) .....	8
3.3 EUT SETUP .....	8
3.4 INSTRUMENT SETUP .....	9
3.5 TEST PROCEDURE .....	9
3.6 SUMMARY OF TEST RESULTS .....	9
3.7 DISTURBANCE VOLTAGE TEST DATA .....	9
3.8 TEST EQUIPMENT LIST AND DETAILS .....	9
3.9 TEST RESULT .....	9
<b>4 - DISTURBANCE VOLTAGE AT THE NETWORK TERMINALS .....</b>	<b>12</b>
4.1 MEASUREMENT UNCERTAINTY .....	12
4.2 LIMIT OF DISTURBANCE VOLTAGE AT THE NETWORK TERMINALS (CLASS B) .....	12
4.3 EUT SETUP .....	12
4.4 INSTRUMENTS SETUP .....	12
4.5 TEST PROCEDURE .....	13
4.6 SUMMARY OF TEST RESULTS .....	13
4.7 DISTURBANCE VOLTAGE TEST DATA .....	13
4.8 TEST EQUIPMENT LIST AND DETAILS .....	13
4.9 TEST RESULT .....	13
<b>5 - RADIATED DISTURBANCES .....</b>	<b>16</b>
5.1 MEASUREMENT UNCERTAINTY .....	16
5.2 LIMIT OF RADIATED DISTURBANCES (CLASS B) .....	16
5.3 EUT SETUP .....	16
5.4 TEST RECEIVER SETUP .....	17
5.5 TEST PROCEDURE .....	17
5.6 CORRECTED AMPLITUDE & MARGIN CALCULATION .....	17
5.7 RADIATED EMISSIONS TEST RESULT .....	17
5.8 TEST EQUIPMENT LIST AND DETAILS .....	18
5.9 TEST RESULT .....	18
<b>6 - HARMONIC CURRENT TEST .....</b>	<b>27</b>
6.1 APPLICATION OF HARMONIC CURRENT EMISSION .....	27
6.2 MEASUREMENT DATA .....	27
6.3 TEST EQUIPMENT LIST AND DETAILS .....	27
6.4 TEST RESULTS .....	27
<b>7 - VOLTAGE FLUCTUATIONS AND FLICKER TEST .....</b>	<b>28</b>
7.1 APPLICATION OF VOLTAGE FLUCTUATIONS AND FLICKER TEST .....	28
7.2 MEASUREMENT DATA .....	28
7.3 TEST EQUIPMENT LIST AND DETAILS .....	28
7.4 TEST RESULTS .....	28
<b>8 - ELECTROSTATIC DISCHARGE IMMUNITY TEST .....</b>	<b>29</b>

8.1 BLOCK DIAGRAM OF TEST SETUP .....	29
8.2 TEST STANDARD .....	29
8.3 SEVERITY LEVELS AND PERFORMANCE CRITERION .....	29
8.4 OPERATING CONDITION OF EUT .....	29
8.5 TEST PROCEDURE .....	29
8.6 TEST EQUIPMENT LIST AND DETAILS .....	30
8.7 TEST RESULTS .....	30
<b>9 - RF FIELD STRENGTH SUSCEPTIBILITY TEST.....</b>	<b>32</b>
9.1 BLOCK DIAGRAM OF TEST .....	32
9.2 TEST STANDARD .....	32
9.3 SEVERITY LEVELS AND PERFORMANCE CRITERION .....	32
9.4 OPERATING CONDITION OF EUT .....	32
9.5 TEST PROCEDURE .....	33
9.6 TEST EQUIPMENT LIST AND DETAILS .....	33
9.7 TEST RESULTS .....	34
<b>10 - ELECTRICAL FAST TRANSIENT/BURST IMMUNITY TEST.....</b>	<b>35</b>
10.1 BLOCK DIAGRAM OF TEST SETUP .....	35
10.2 TEST STANDARD .....	35
10.3 SEVERITY LEVELS AND PERFORMANCE CRITERION .....	35
10.4 OPERATING CONDITION OF EUT .....	35
10.5 TEST PROCEDURE .....	36
10.6 TEST EQUIPMENT LIST AND DETAILS .....	36
10.7 TEST RESULT .....	36
<b>11 - SURGE IMMUNITY TEST.....</b>	<b>37</b>
11.1 BLOCK DIAGRAM OF TEST SETUP .....	37
11.2 TEST STANDARD .....	37
11.3 SEVERITY LEVELS AND PERFORMANCE CRITERION .....	37
11.4 OPERATING CONDITION OF EUT .....	37
11.5 TEST PROCEDURE .....	37
11.6 TEST EQUIPMENT LIST AND DETAILS .....	38
11.7 TEST RESULT .....	38
<b>12 - CONDUCTED SUSCEPTIBILITY TEST.....</b>	<b>39</b>
12.1 BLOCK DIAGRAM OF TEST SETUP .....	39
12.2 TEST STANDARD .....	39
12.3 SEVERITY LEVELS AND PERFORMANCE CRITERION .....	39
12.4 OPERATING CONDITION OF EUT .....	39
12.5 TEST PROCEDURE .....	39
12.6 TEST EQUIPMENT LIST AND DETAILS .....	40
12.7 TEST RESULTS .....	40
<b>13 - VOLTAGE DIPS, SHORT INTERRUPTIONS IMMUNITY TESTS.....</b>	<b>42</b>
13.1 BLOCK DIAGRAM OF TEST SETUP .....	42
13.2 TEST STANDARD .....	42
13.3 SEVERITY LEVELS AND PERFORMANCE CRITERION .....	42
13.4 EUT CONFIGURATION .....	42
13.5 OPERATING CONDITION OF EUT .....	42
13.6 TEST PROCEDURE .....	42
13.7 TEST EQUIPMENT LIST AND DETAILS .....	43
13.8 TEST RESULT .....	43
<b>14 - TEST RESULTS .....</b>	<b>44</b>
<b>APPENDIX A - PRODUCT LABELING .....</b>	<b>45</b>
<b>APPENDIX B - EUT PHOTOGRAPHS.....</b>	<b>46</b>
<b>APPENDIX C - TEST SETUP PHOTOGRAPHS.....</b>	<b>49</b>

## 1 - GENERAL INFORMATION

### 1.1 Product Description for Equipment Under Test (EUT)

#### Client Information

Applicant: **Fanvil Technology Co., Ltd**  
 Address of applicant: Level 3, Block A, Gaoxinqi Building, Anhua Industrial Park, Qianjin 1 Road, 35th District, Bao'An, Shenzhen, 518101 P.R. China  
 Manufacturer: **Fanvil Technology Co., Ltd**  
 Address of manufacturer: Level 3, Block A, Gaoxinqi Building, Anhua Industrial Park, Qianjin 1 Road, 35th District, Bao'An, Shenzhen, 518101 P.R. China

#### General Description of E.U.T

EUT Description: **X3**  
 Trade Mark: **Fanvil**  
 Model No.: **X3, X3P, X3E, X3EP**  
 Test Model No.: **X3P**  
 Adapter Power Rating: **Model: F05L5-050060SPAU**  
**Input: AC 100-240V 50/60Hz 0.2A**  
**Output: DC 5V 600mA**  
 Power Rating: **Input: DC 5V 600mA**

Remark: \* The test data gathered are from the production sample provided by the manufacturer.  
 \* Supplementary models have the same appearance, but with different ways of power supply.  
 \* HCT15JR-0996E is produced on the basis of BCT14JR-1474E.

#### General Description of Test Auxiliary

AUX Description:	Manufacturer	Model No.	Certificate
Laptop	LENOVO	0658	CE,FCC
8-Port 10/100Mbps Desktop Switch with 4-port POE	TP-LINK	TL-SF1008P	CE,FCC

## 1.2 Test Standards

The following Declaration of Conformity report of EUT is prepared in accordance with

EN 55022:2010

EN 55024:2010

EN 61000-3-2:2014

EN 61000-3-3:2013

The objective of the manufacturer is to demonstrate compliance with the described standards above.

## 1.3 Test Summary

For the EUT described above. The standards used were EN 55022 Class B for Emissions & EN 55024 for Immunity.

Table 1 : Tests Carried Out Under EN 55022:2010

Standard	Test Items	Status
EN 55022:2010	Disturbance Voltage at The Mains Terminals (150KHz To 30MHz)	√
	Disturbance Voltage at the Telecommunication Port (0.15MHz To 30MHz)	√
	Radiated Disturbances (30MHz To 6GHz)	√

- √ Indicates that the test is applicable  
 × Indicates that the test is not applicable

Table 2 : Tests Carried Out Under EN 61000-3-2:2014/ EN 61000-3-3:2013

Standard	Test Items	Status
EN 61000-3-2:2014	Harmonic Current Test	√
EN 61000-3-3:2013	Voltage Fluctuations and Flicker Test	√

- √ Indicates that the test is applicable  
 × Indicates that the test is not applicable

Table 3 : Tests Carried Out Under EN 55024:2010

Standard	Test Items	Status
EN61000-4-2:2009	Electrostatic discharge Immunity	√
EN61000-4-3:2006+A2:2010	Radiated Susceptibility (80MHz to 1GHz)	√
EN61000-4-4:2012	Electrical Fast Transient/Burst Immunity	√
EN61000-4-5:2014	Surge Immunity	√
EN61000-4-6:2014	Conducted Susceptibility (150kHz to 80MHz)	√
EN61000-4-8:2010	Power Frequency Magnetic Field Immunity (50/60Hz)	×
EN61000-4-11:2004	Voltage Dips, Short Interruptions Immunity	√

- √ Indicates that the test is applicable  
 × Indicates that the test is not applicable

## 1.4 Test Methodology

All measurements contained in this report were conducted with CISPR 16-1-1: 2006, radio disturbance and immunity measuring apparatus, and CISPR16-2-3: 2010, Method of measurement of disturbances and immunity.

All measurement required was performed at Shenzhen Hongcai Testing Technology Co.,Ltd 1st-3rd Floor,Building C,Shuanghuan Xin Yi Dai Hi-Tech Industrial Park,No.8 Baoqing Road,Baolong Industrial Zone,Longgang District, Shenzhen, Guangdong, China

## 1.5 Test Facility

The test facility is recognized, certified, or accredited by the following organizations:

### **CNAS – Registration No.: L3923**

Shenzhen Hongcai Testing Technology Co.,Ltd. to ISO/IEC 17025:2005 General Requirements for the Competence of Testing and Calibration Laboratories(CNAS-CL01 Accreditation Criteria for the Competence of Testing and Calibration Laboratories) for the competence in the field of testing. The acceptance letter from the CNAS is maintained in our files: Registration: L3923, June 1,2015.

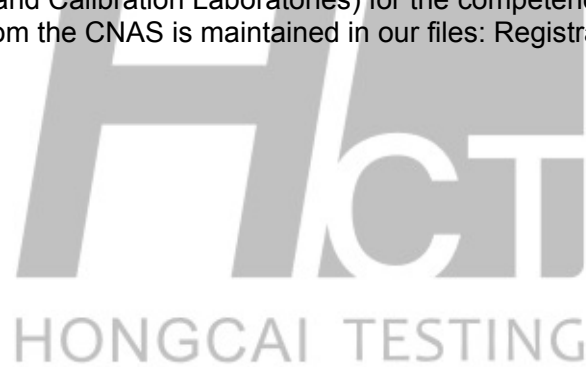

## 2 - SYSTEM TEST CONFIGURATION

---

### 2.1 Justification

The system was configured for testing in a typical fashion (as normally used by a typical user).

### 2.2 EUT Exercise Software

The EUT exercising program used during radiated and conducted testing was designed to exercise the various system components in a manner similar to a typical use. The software offered by manufacture, can let the EUT being normal operation.

### 2.3 Special Accessories

As shown in section 2.5, interface cable used for compliance testing is shielded as normally supplied by **Fanvil Technology Co . , Ltd** and its respective support equipment manufacturers.

### 2.4 Equipment Modifications

The EUT tested was not modified by HCT.



### 2.5 Test Setup Diagram

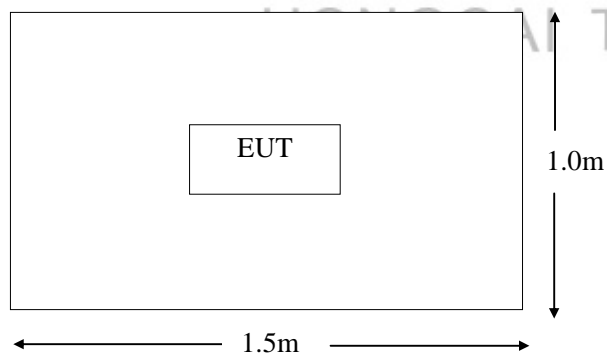

### 3 - DISTURBANCE VOLTAGE AT THE MAINS TERMINALS

#### 3.1 Measurement Uncertainty

All measurements involve certain levels of uncertainties, especially in field of EMC. The factors contributing to uncertainties are spectrum analyzer, cable loss, and LISN.

The Treatment of Uncertainty in EMC Measurements, the best estimate of the uncertainty of any conducted emissions measurement is 3.4 dB.

#### 3.2 Limit of Disturbance Voltage At The Mains Terminals (Class B)

Frequency Range (MHz)	Limits ( dBuV)	
	Quasi-Peak	Average
0.150~0.500	66~56	56~46
0.500~5.000	56	46
5.000~30.00	60	50

Note: (1) The tighter limit shall apply at the edge between two frequency bands.

#### 3.3 EUT Setup

The setup of EUT is according with CISPR 16-1-1: 2006, CISPR 16-2-3: 2010 measurement procedure. The specification used was the EN 55022 limits.

The EUT was placed center and the back edge of the test table.

The AV cables were draped along the test table and bundled to 30-40cm in the middle.

The spacing between the peripherals was 10 cm.

Maximum emission emitted from EUT was determined by manipulating the EUT, support equipment, interconnecting cables and varying the mode of operation and the levels in the final result of the test were recorded with the EUT running in the operating mode that maximum emission was emitted.

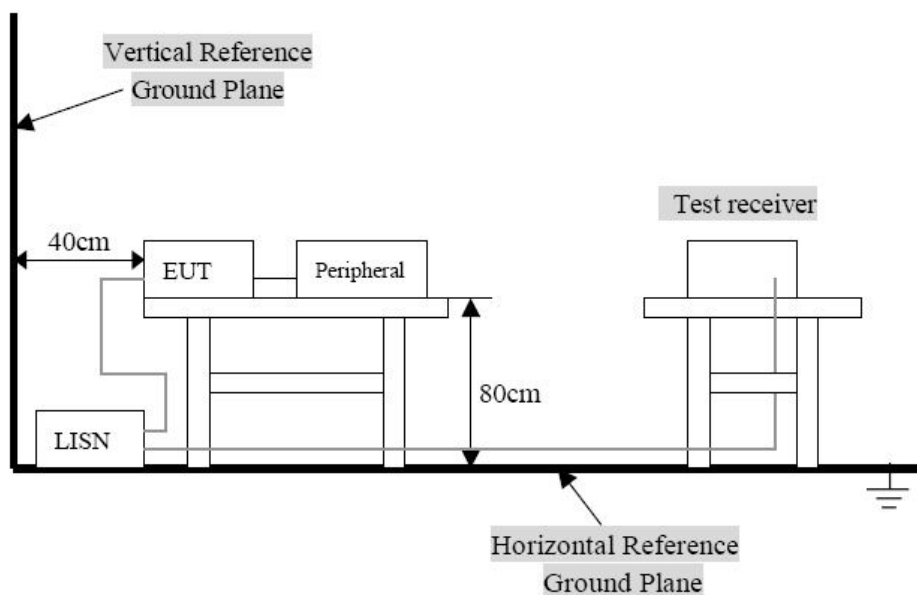

### 3.4 Instrument Setup

The test receiver was set with the following configurations:

Test Receiver Setting:

Frequency Range.....150 KHz to 30 MHz  
 Detector.....Peak & Quasi-Peak & Average  
 Sweep Speed.....Auto  
 IF Band Width.....9 KHz

### 3.5 Test Procedure

During the conducted emission test, the EUT power cord was connected to the auxiliary outlet of the first Artificial Mains.

Maximizing procedure was performed on the six (6) highest emissions to ensure EUT compliance using all installation combination.

All data was recorded in the peak detection mode. Quasi-peak and Average readings were only performed when an emission was found to be marginal (within -10 dB $\mu$ V of specification limits). Quasi-peak readings are distinguished with a "QP". Average readings are distinguished with a "AV".

### 3.6 Summary of Test Results

According to the data in section 3.6, the EUT complied with the EN 55022 Conducted margin, with the worst margin reading of:

### 3.7 Disturbance Voltage Test Data

Temperature ( °C )	22~25
Humidity ( %RH )	50~60
Barometric Pressure ( mbar )	950~1000
EUT	X3
M/N	X3P
Operating Mode	Normal operation

Test data see following pages

### 3.8 Test Equipment List and Details

No.	Instrument no.	Equipment	Manufacturer	Model No.	S/N	Last Calculator	Due Calculator
1	BCT-EMC001	EMI Test Receiver	R&S	ESCI	100687	2014-4-24	2015-4-23
2	BCT-EMC020	Teo Line Single Phase Module	SCHWARZBECK	NSLK8128	8128247	2014-10-30	2015-10-29
3	BCT-EMC032	10dB attenuator	ELECTRO-METRICS	EM-7600	836	2014-4-24	2015-4-23

### 3.9 Test Result

**PASS**

### Conducted Emission Test Data

EUT: X3  
 M/N: X3P  
 Operating Condition: Normal operation  
 Test Site: Shielded Room  
 Operator: Chen  
 Test Specification: AC 230V/50Hz for Adapter  
 Comment: Live Line  
 Start of Test: 10/27/2014 15:32 Tem:24°C Hum:60%

**SCAN TABLE: "Voltage (150K-30M) FIN"**  
 Short Description: 150K-30M Voltage

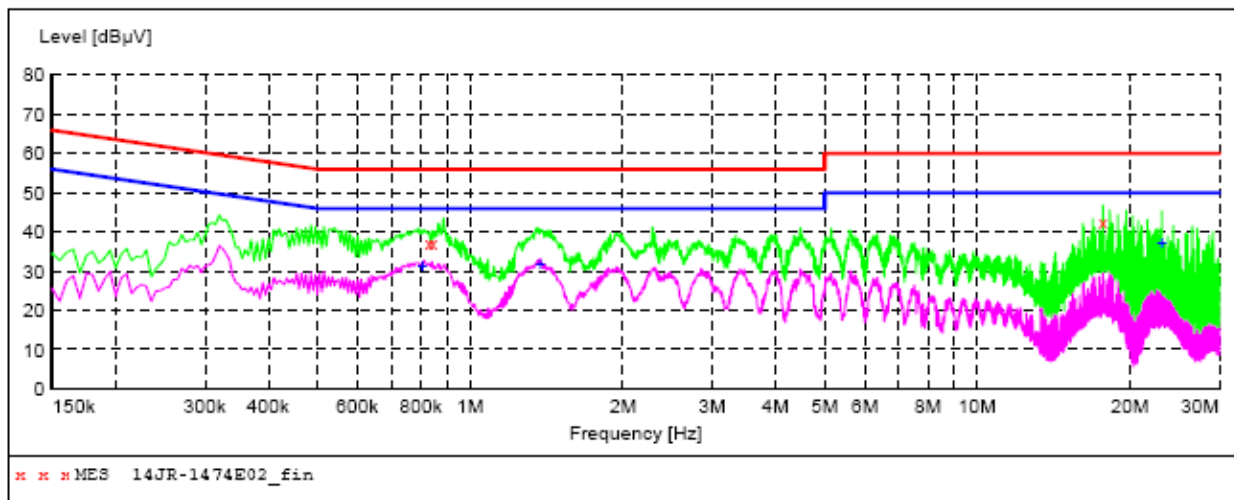

#### MEASUREMENT RESULT: "14JR-1474E02\_fin"

10/27/2014 15:32

Frequency MHz	Level dBµV	Transd dB	Limit dBµV	Margin dB	Detector	Line	PE
0.830000	37.30	10.4	56	18.7	QP	L1	GND
0.845000	37.00	10.4	56	19.0	QP	L1	GND
17.695000	42.40	10.7	60	17.6	QP	L1	GND

#### MEASUREMENT RESULT: "14JR-1474E02\_fin2"

10/27/2014 15:32

Frequency MHz	Level dBµV	Transd dB	Limit dBµV	Margin dB	Detector	Line	PE
0.805000	31.60	10.4	46	14.4	AV	L1	GND
1.375000	31.80	10.4	46	14.2	AV	L1	GND
23.130000	37.20	10.8	50	12.8	AV	L1	GND

### Conducted Emission Test Data

EUT: X3  
 M/N: X3P  
 Operating Condition: Normal operation  
 Test Site: Shielded Room  
 Operator: Chen  
 Test Specification: AC 230V/50Hz for Adapter  
 Comment: Neutral Line  
 Start of Test: 10/27/2014 15:35 Tem:24°C Hum:60%

**SCAN TABLE: "Voltage (150K-30M) FIN"**  
 Short Description: 150K-30M Voltage

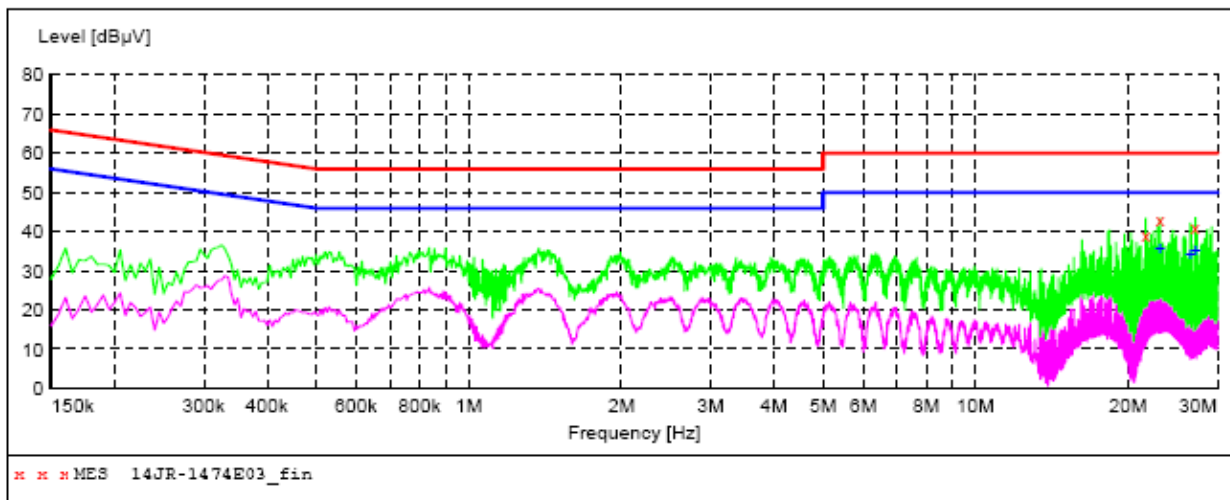

#### MEASUREMENT RESULT: "14JR-1474E03\_fin"

10/27/2014 15:35

Frequency MHz	Level dBµV	Transd dB	Limit dBµV	Margin dB	Detector	Line	PE
21.665000	39.30	10.7	60	20.7	QP	N	GND
23.130000	42.80	10.8	60	17.2	QP	N	GND
27.160000	41.40	10.9	60	18.6	QP	N	GND

#### MEASUREMENT RESULT: "14JR-1474E03\_fin"

10/27/2014 15:35

Frequency MHz	Level dBµV	Transd dB	Limit dBµV	Margin dB	Detector	Line	PE
23.130000	35.60	10.8	50	14.4	AV	N	GND
26.550000	34.10	10.9	50	15.9	AV	N	GND
27.160000	35.30	10.9	50	14.7	AV	N	GND

## 4 - DISTURBANCE VOLTAGE AT THE NETWORK TERMINALS

### 4.1 Measurement Uncertainty

All measurements involve certain levels of uncertainties, especially in field of EMC. The factors contributing to uncertainties are spectrum analyzer, cable loss, and LISN.

The Treatment of Uncertainty in EMC Measurements, the best estimate of the uncertainty of any conducted emissions measurement is 3.4 dB.

### 4.2 Limit of Disturbance Voltage at The Network Terminals (Class B)

Frequency Range (MHz)	Limits ( dBuV)	
	Quasi-Peak	Average
0.150~0.500	84~74	74~64
0.5000~30.00	74	64

Note: (1) The limits decrease linearly with the logarithm of the frequency in the range 0.15 MHz to 0.5 MHz

### 4.3 EUT Setup

The setup of EUT is according with CISPR 16-1-1: 2006, CISPR16-2-3: 2010 measurement procedure. The specification used was the EN 55022 limits.

The EUT was placed center and the back edge of the test table.

The AV cables were draped along the test table and bundled to 30-40cm in the middle.

The spacing between the peripherals was 10 cm.

Maximum emission emitted from EUT was determined by manipulating the EUT, support equipment, interconnecting cables and varying the mode of operation and the levels in the final result of the test were recorded with the EUT running in the operating mode that maximum emission was emitted.

### 4.4 Instruments Setup

The receiver was set with the following configurations:

Test Receiver Setting:

Frequency Range.....150 KHz to 30 MHz  
 Detector.....Peak & Quasi-Peak & Average  
 Sweep Speed.....Auto  
 IF Band Width.....9 KHz

#### 4.5 Test Procedure

During the conducted emission test, the EUT power cord was connected to the auxiliary outlet of the first Artificial Mains.

Maximizing procedure was performed on the six (6) highest emissions to ensure EUT compliance using all installation combination.

All data was recorded in the peak detection mode. Quasi-peak and Average readings were only performed when an emission was found to be marginal (within -10 dB $\mu$ V of specification limits). Quasi-peak readings are distinguished with a "QP". Average readings are distinguished with a "AV".

#### 4.6 Summary of Test Results

According to the data in section 3.6, the EUT complied with EN55022 Conducted margin, with the worst margin reading of:

#### 4.7 Disturbance Voltage Test Data

Temperature ( °C )	22~23
Humidity ( %RH )	50~60
Barometric Pressure ( mbar )	950~1000
EUT	X3
M/N	X3P
Operating Mode	Normal operation

Test data see following pages

**Remark:** (1) When PK reading is less than relevant limit 20dB, the QP reading and AV reading will not be recorded.  
 (2) Where QP reading is less than relevant AV limit, the AV reading will not be measured

Note: (this result is the worst result in all power supply modes)

#### 4.8 Test Equipment List and Details

No.	Instrument no.	Equipment	Manufacturer	Model No.	S/N	Last Calculator	Due Calculator
1	BCT-EMC001	EMI Test Receiver	R&S	ESCI	100687	2014-4-24	2015-4-23
2	BCT-EMC033	ISN	TESEQ	ISN-T800	30301	2014-4-24	2015-4-23

#### 4.9 Test Result

**Pass**

### Conducted Emission Test Data

EUT: X3  
 M/N: X3P  
 Operating Condition: Normal operation  
 Test Site: Shielded Room  
 Operator: Chen  
 Test Specification: AC 230V/50Hz for Adapter  
 Comment: LAN Line  
 Start of Test: 10/27/2014 17:23 Tem:24°C Hum:60%

**SCAN TABLE: "Voltage (150K-30M) FIN"**  
 Short Description: 150K-30M Voltage

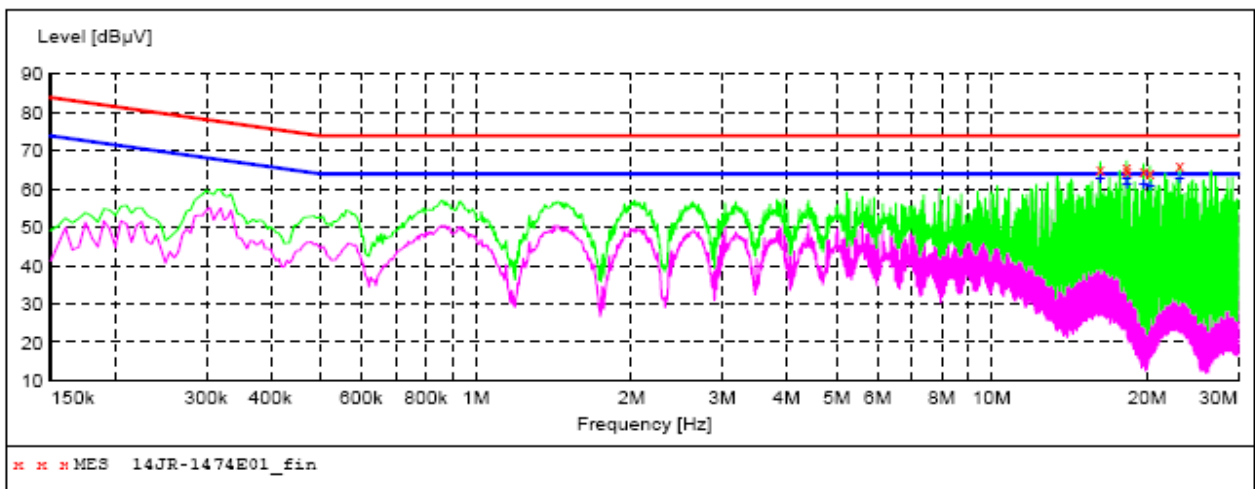

#### MEASUREMENT RESULT: "14JR-1474E01\_fin"

10/27/2014 17:23

Frequency MHz	Level dBµV	Transd dB	Limit dBµV	Margin dB	Detector	Line	PE
16.230000	65.40	10.8	74	8.6	QP	LAN	GND
18.245000	65.90	10.7	74	8.1	QP	LAN	GND
18.305000	64.60	10.7	74	9.4	QP	LAN	GND
19.710000	64.80	10.7	74	9.2	QP	LAN	GND
20.260000	64.20	10.7	74	9.8	QP	LAN	GND
23.130000	66.30	10.8	74	7.7	QP	LAN	GND

#### MEASUREMENT RESULT: "14JR-1474E01\_fin2"

10/27/2014 17:23

Frequency MHz	Level dBµV	Transd dB	Limit dBµV	Margin dB	Detector	Line	PE
16.230000	63.00	10.8	64	1.0	AV	LAN	GND
18.245000	62.70	10.7	64	1.3	AV	LAN	GND
18.305000	61.50	10.7	64	2.5	AV	LAN	GND
19.710000	61.30	10.7	64	2.7	AV	LAN	GND
20.260000	60.70	10.7	64	3.3	AV	LAN	GND
23.130000	62.70	10.8	64	1.3	AV	LAN	GND

### Conducted Emission Test Data

EUT: X3  
 M/N: X3P  
 Operating Condition: Normal operation  
 Test Site: Shielded Room  
 Operator: Chen  
 Test Specification: AC 230V/50Hz for POE  
 Comment: POE Line  
 Start of Test: 11/10/2014 09:52 Tem:24°C Hum:60%

**SCAN TABLE: "Voltage(150K-30M)FIN"**  
 Short Description: 150K-30M Voltage

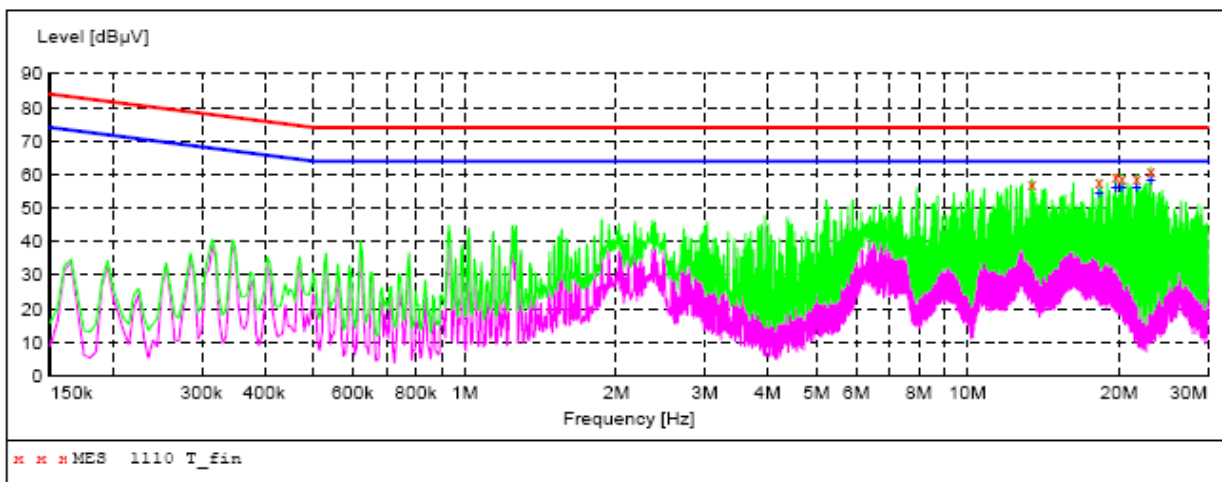

#### MEASUREMENT RESULT: "1110 T\_fin"

11/10/2014 09:52

Frequency MHz	Level dBµV	Transd dB	Limit dBµV	Margin dB	Detector	Line	PE
13.420000	57.50	10.7	74	16.5	QP	POE	GND
18.245000	57.90	10.7	74	16.1	QP	POE	GND
19.710000	59.40	10.7	74	14.6	QP	POE	GND
20.260000	58.90	10.7	74	15.1	QP	POE	GND
21.665000	59.10	10.7	74	14.9	QP	POE	GND
23.130000	61.20	10.8	74	12.8	QP	POE	GND

#### MEASUREMENT RESULT: "1110 T\_fin2"

11/10/2014 09:52

Frequency MHz	Level dBµV	Transd dB	Limit dBµV	Margin dB	Detector	Line	PE
18.245000	54.70	10.7	64	9.3	AV	POE	GND
19.710000	56.40	10.7	64	7.6	AV	POE	GND
20.260000	55.90	10.7	64	8.1	AV	POE	GND
21.665000	56.10	10.7	64	7.9	AV	POE	GND
23.130000	58.50	10.8	64	5.5	AV	POE	GND

## 5 - RADIATED DISTURBANCES

### 5.1 Measurement Uncertainty

All measurements involve certain levels of uncertainties, especially in field of EMC. The factors contributing to uncertainties are spectrum analyzer, cable loss, antenna factor calibration, antenna directivity, antenna factor variation with height, antenna phase center variation, antenna factor frequency interpolation, measurement distance variation, site imperfections, mismatch (average), and system repeatability.

The Treatment of Uncertainty in EMC Measurements, the best estimate of the uncertainty of a radiation emissions measurement is 4.0 dB.

### 5.2 Limit of Radiated Disturbances (Class B)

Frequency (MHz)	Distance (Meters)	Field Strengths Limits (dB $\mu$ V/m)
30 ~ 230	3	40
230 ~ 1000	3	47

Frequency (MHz)	Distance (Meters)	Field Strengths Limits AV(dB $\mu$ V/m)	Field Strengths Limits PK(dB $\mu$ V/m)
1000~3000	3	50	70
3000-6000	3	54	74

Note: (1) The tighter limit shall apply at the edge between two frequency bands.  
 (2) Distance refers to the distance in meters between the test instrument antenna and the closest point of any part of the E.U.T.

### 5.3 EUT Setup

The radiated emission tests were performed in the open area 3-meter test site, using the setup accordance with the CISPR 16-1-1: 2006, CISPR16-2-3: 2010. The specification used was EN 55022 Class B limits.

The EUT was placed on the center of the test table.

Maximum emission emitted from EUT was determined by manipulating the EUT, support equipment, interconnecting cables and varying the mode of operation and the levels in the final result of the test were recorded with the EUT running in the operating mode that maximum emission was emitted.

Block diagram of test setup (In chamber)

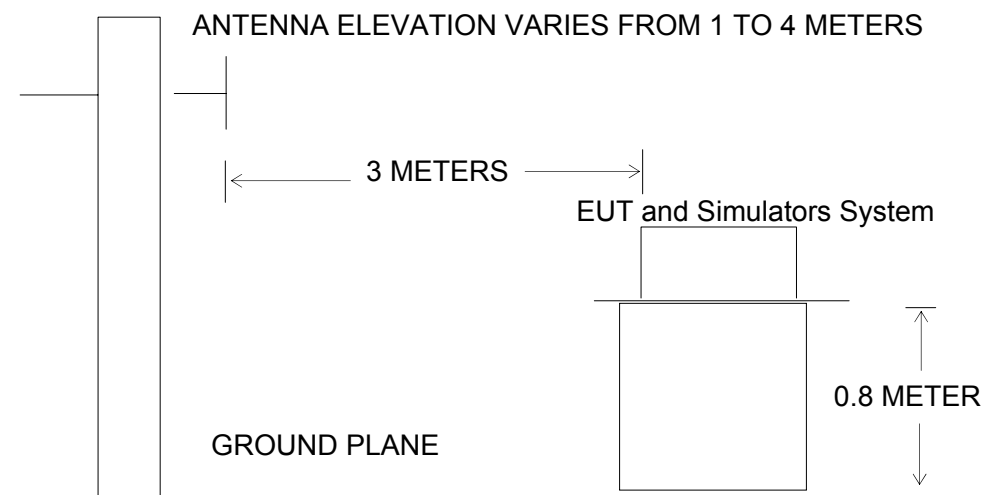

## 5.4 Test Receiver Setup

According to EN 55022 rules, the frequency was investigated from 30 to 1000 MHz. During the radiated emission test, the test receiver was set with the following configurations:

Test Receiver Setting:

Detector.....Peak & Quasi-Peak  
 IF Band Width.....120KHz  
 Frequency Range.....30MHz to 1000MHz  
 Turntable Rotated.....0 to 360 degrees

Antenna Position:

Height.....1m to 4m  
 Polarity.....Horizontal and Vertical

## 5.5 Test Procedure

Maximizing procedure was performed on the highest emissions to ensure that the EUT complied with all installation combinations.

All data was recorded in the peak detection mode. Quasi-peak readings performed only when an emission was found to be marginal (within -10 dB $\mu$ V of specification limits), and are distinguished with a "QP" in the data table.

## 5.6 Corrected Amplitude & Margin Calculation

The Corrected Amplitude is calculated by adding the Antenna Factor and Cable Factor, and subtracting the Amplifier Gain from the Amplitude reading. The basic equation is as follows:

$$\text{Corr. Ampl.} = \text{Indicated Reading} + \text{Antenna Factor} + \text{Cable Factor} - \text{Amplifier Gain}$$

The "Margin" column of the following data tables indicates the degree of compliance with the applicable limit. For example, a margin of 7dB $\mu$ V means the emission is 7dB $\mu$ V below the maximum limit for Class B. The equation for margin calculation is as follows:

$$\text{Margin} = \text{Class B Limit} - \text{Corr. Ampl.}$$

## 5.7 Radiated Emissions Test Result

Temperature ( °C )	22~25
Humidity ( %RH )	50~55
Barometric Pressure ( mbar )	950~1000
EUT	X3
M/N	X3P
Operating Mode	Normal operation

### 5.8 Test Equipment List and Details

No.	Instrument no.	Equipment	Manufacturer	Model No.	S/N	Last Calculator	Due Calculator
1	BCT-EMC001	EMI Test Receiver	R&S	ESCI	100687	2014-4-24	2015-4-23
2	BCT-EMC002	EMI Test Receiver	R&S	ESPI	100097	2014-10-30	2015-10-29
3	BCT-EMC018	TRILOG Broadband Test-Antenna	SCHWARZBECK	VULB9163	9163-324	2014-5-18	2015-5-17
4	BCT-EMC019	Horn Antenna	SCHWARZBECK	BBHA9120A	0499	2014-11-26	2015-11-25
5	BCT-EMC037	Broadband preamplifier	SCHWARZBECK	BBV9718	9718-182	2014-4-18	2015-4-17

### 5.9 Test Result

**PASS**



### Radiated Emission Test Data

EUT: X3  
 M/N: X3P  
 Operating Condition: Normal operation  
 Test Site: 3m CHAMBER  
 Operator: Yang  
 Test Specification: AC 230V/50Hz for Adapter  
 Comment: Polarization: Horizontal  
 Start of Test: 11/5/2014 16:22 Tem:25°C Hum:50%

**SWEEP TABLE: "test (30M-1G)"**

Short Description:		Field Strength			
Start	Stop	Detector	Meas. Time	IF Bandw.	Transducer
Frequency	Frequency	MaxPeak	Coupled	100 kHz	VULB9163 NEW
30.0 MHz	1.0 GHz				

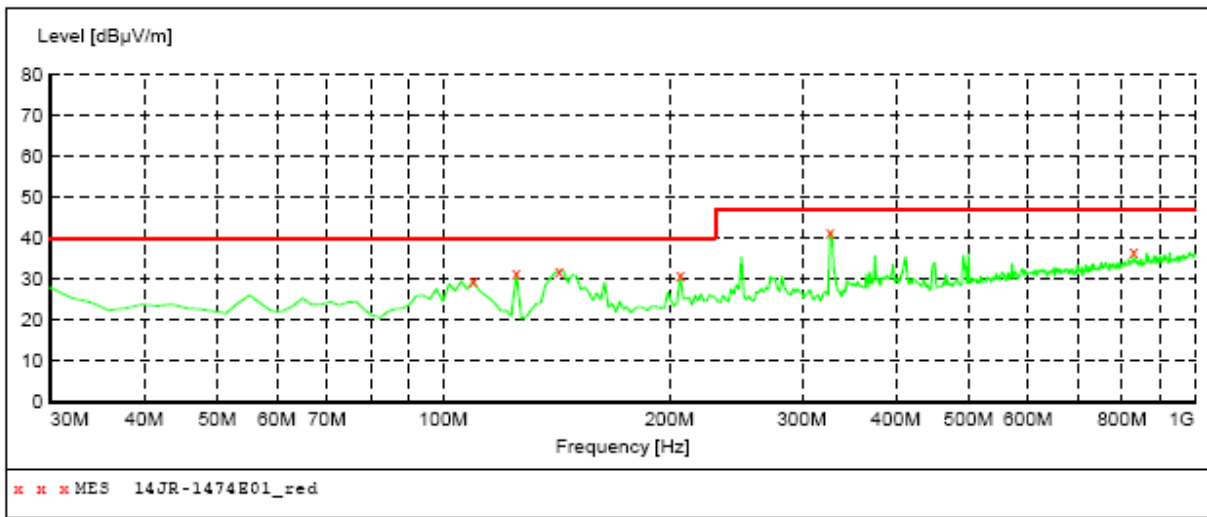

**MEASUREMENT RESULT: "14JR-1474E01\_red"**

11/5/2014 16:22

Frequency MHz	Level dBuV/m	Transd dB	Limit dBuV/m	Margin dB	Det.	Height cm	Azimuth deg	Polarization
109.540000	29.60	16.6	40.0	10.4	QP	100.0	0.00	HORIZONTAL
125.060000	31.50	13.8	40.0	8.5	QP	100.0	0.00	HORIZONTAL
142.520000	32.10	12.3	40.0	7.9	QP	100.0	0.00	HORIZONTAL
206.540000	31.10	15.0	40.0	8.9	QP	100.0	0.00	HORIZONTAL
326.820000	41.50	19.5	47.0	5.5	QP	100.0	0.00	HORIZONTAL
829.280000	36.80	28.4	47.0	10.2	QP	100.0	0.00	HORIZONTAL

### Radiated Emission Test Data

EUT: X3  
 M/N: X3P  
 Operating Condition: Normal operation  
 Test Site: 3m CHAMBER  
 Operator: Yang  
 Test Specification: AC 230V/50Hz for Adapter  
 Comment: Polarization: Vertical  
 Start of Test: 11/5/2014 16:25 Tem:25°C Hum:50%

**SWEEP TABLE: "test (30M-1G)"**

Short Description:		Field Strength			
Start	Stop	Detector	Meas. Time	IF Bandw.	Transducer
30.0 MHz	1.0 GHz	MaxPeak	Coupled	100 kHz	VULB9163 NEW

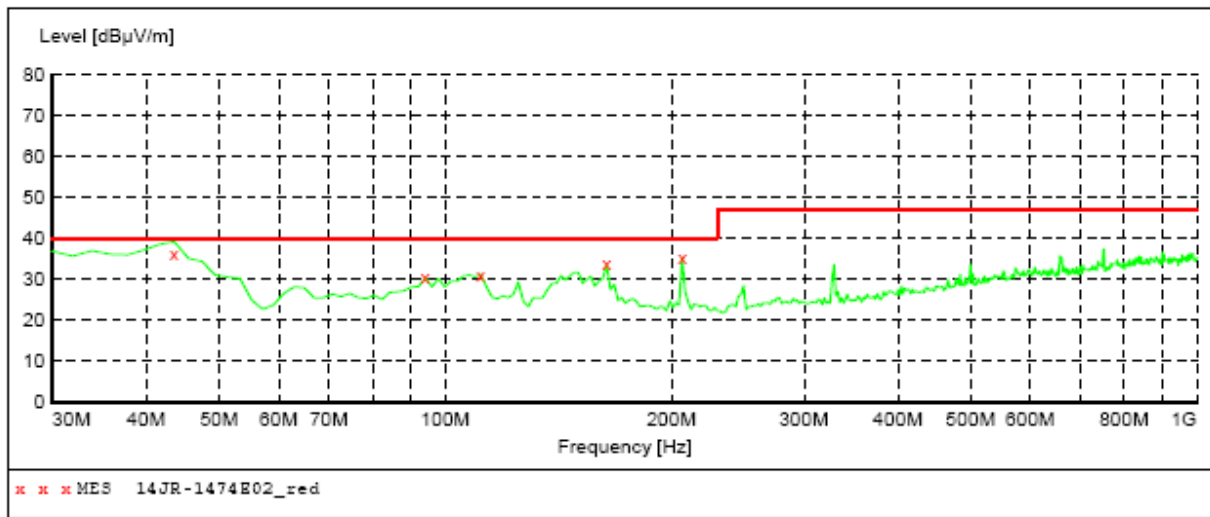

**MEASUREMENT RESULT: "14JR-1474E02\_red"**

11/5/2014 16:25

Frequency MHz	Level dBµV/m	Transd dB	Limit dBµV/m	Margin dB	Det.	Height cm	Azimuth deg	Polarization
43.580000	36.20	15.9	40.0	3.8	QP	100.0	0.00	VERTICAL
94.020000	30.40	16.9	40.0	9.6	QP	100.0	0.00	VERTICAL
111.480000	31.20	16.2	40.0	8.8	QP	100.0	0.00	VERTICAL
163.860000	33.70	12.9	40.0	6.3	QP	100.0	0.00	VERTICAL
206.540000	35.40	15.0	40.0	4.6	QP	100.0	0.00	VERTICAL

### Radiated Emission Test Data

EUT: X3  
 M/N: X3P  
 Operating Condition: Normal operation  
 Test Site: 3m CHAMBER  
 Operator: Yang  
 Test Specification: AC 230V/50Hz for POE  
 Comment: Polarization: Horizontal  
 Start of Test: 10/24/2014 12:04 Tem:25°C Hum:50%

**SWEEP TABLE: "test (30M-1G)"**

Short Description:		Field Strength			
Start	Stop	Detector	Meas. Time	IF Bandw.	Transducer
Frequency	Frequency	MaxPeak	300.0 ms	120 kHz	JB1
30.0 MHz	1.0 GHz				

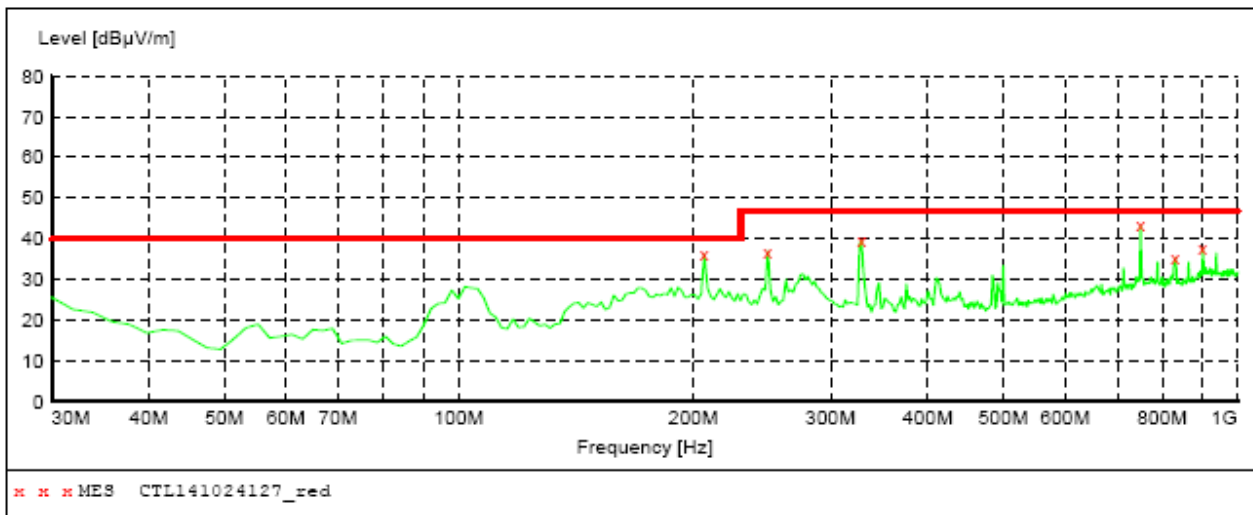

**MEASUREMENT RESULT: "CTL141024127\_red"**

10/24/2014 12:04PM

Frequency MHz	Level dBµV/m	Transd dB	Limit dBµV/m	Margin dB	Det.	Height cm	Azimuth deg	Polarization
206.540000	36.20	14.3	40.0	3.8	QP	0.0	0.00	HORIZONTAL
249.220000	37.00	14.1	47.0	10.0	QP	0.0	0.00	HORIZONTAL
328.760000	39.70	16.2	47.0	7.3	QP	0.0	0.00	HORIZONTAL
749.740000	43.30	24.3	47.0	3.7	QP	0.0	0.00	HORIZONTAL
831.220000	35.40	25.1	47.0	11.6	QP	0.0	0.00	HORIZONTAL
901.060000	37.50	26.1	47.0	9.5	QP	0.0	0.00	HORIZONTAL

### Radiated Emission Test Data

EUT: X3  
M/N: X3P  
Operating Condition: Normal operation  
Test Site: 3m CHAMBER  
Operator: Yang  
Test Specification: AC 230V/50Hz for POE  
Comment: Polarization: Vertical  
Start of Test: 10/24/2014 12:02 Tem:25°C Hum:50%

**SWEEP TABLE: "test (30M-1G)"**

Short Description:		Field Strength				Transducer
Start	Stop	Detector	Meas. Time	IF Bandw.		
Frequency	Frequency					
30.0 MHz	1.0 GHz	MaxPeak	300.0 ms	120 kHz	JB1	

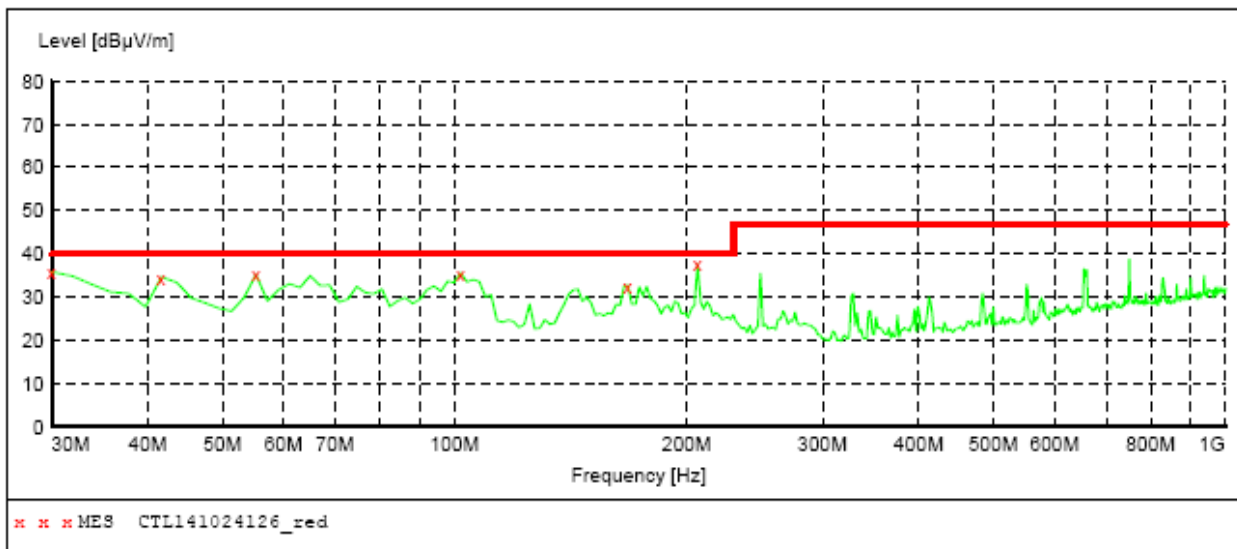

**MEASUREMENT RESULT: "CTL141024126\_red"**

10/24/2014 12:02PM

Frequency MHz	Level dBµV/m	Transd dB	Limit dBµV/m	Margin dB	Det.	Height cm	Azimuth deg	Polarization
30.000000	35.80	21.1	40.0	4.2	QP	0.0	0.00	VERTICAL
41.640000	34.60	12.5	40.0	5.4	QP	0.0	0.00	VERTICAL
55.220000	35.20	8.3	40.0	4.8	QP	0.0	0.00	VERTICAL
101.780000	35.60	12.0	40.0	4.4	QP	0.0	0.00	VERTICAL
167.740000	32.70	13.7	40.0	7.3	QP	0.0	0.00	VERTICAL
206.540000	37.60	14.3	40.0	2.4	QP	0.0	0.00	VERTICAL

### Radiated Emission Test Data of Above 1GHz

EUT: X3  
 M/N: X3P  
 Operating Condition: Normal operation  
 Test Site: 3m CHAMBER  
 Operator: Yang  
 Test Specification: AC 230V/50Hz for Adapter  
 Comment: Polarization: Horizontal  
 Start of Test: Tem:25°C Hum:50%

**SWEEP TABLE: "test (1G-6G)"**

Short Description:		Field Strength			
Start Frequency	Stop Frequency	Detector	Meas. Time	IF Bandw.	Transducer
1.0 GHz	6.0 GHz	MaxPeak	Coupled	1 MHz	BBHA 9120 A
Average					

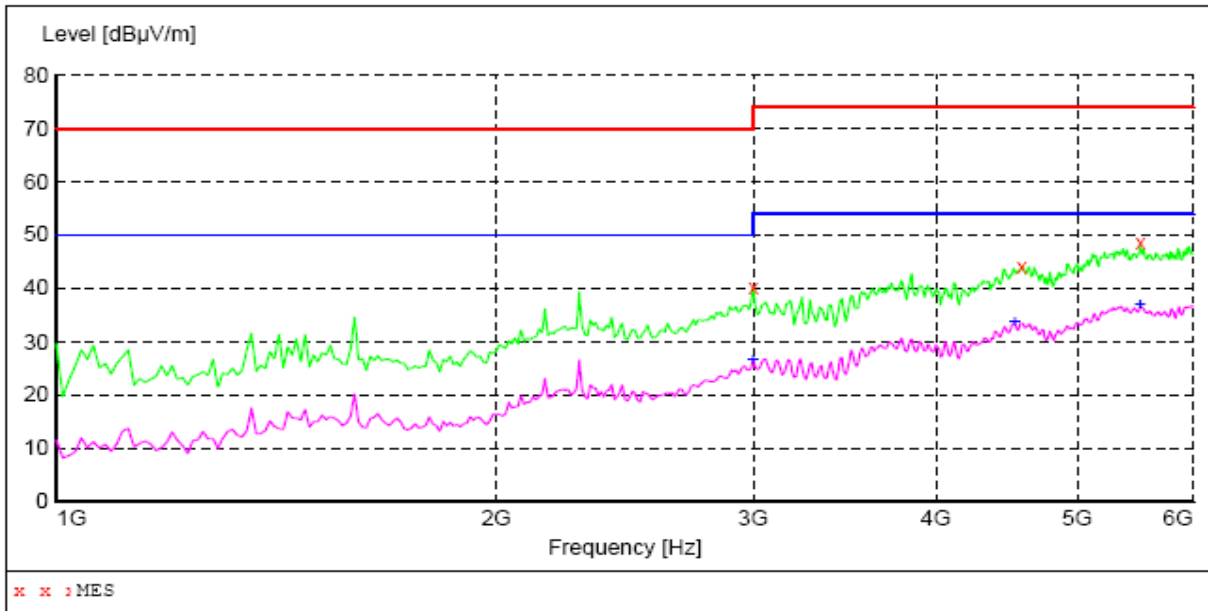

**MEASUREMENT RESULT:**

Frequency MHz	Level dBuV/m	Transd dB	Limit dBuV/m	Margin dB	Det.	Height cm	Azimuth deg	Polarization
3000.000000	40.20	-5.9	70.0	29.8	PK	100.0	0.00	HORIZONTAL
4580.000000	44.10	0.4	74.0	29.9	PK	100.0	0.00	HORIZONTAL
5520.000000	48.40	3.5	74.0	25.6	PK	100.0	0.00	HORIZONTAL

**MEASUREMENT RESULT:**

Frequency MHz	Level dBuV/m	Transd dB	Limit dBuV/m	Margin dB	Det.	Height cm	Azimuth deg	Polarization
3000.000000	26.70	-5.9	50.0	23.3	AV	100.0	0.00	HORIZONTAL
4530.000000	33.60	0.1	54.0	20.4	AV	100.0	0.00	HORIZONTAL
5520.000000	36.80	3.5	54.0	17.2	AV	100.0	0.00	HORIZONTAL

### Radiated Emission Test Data of Above 1GHz

EUT: X3  
 M/N: X3P  
 Operating Condition: 3m CHAMBER  
 Test Site: Yang  
 Operator: AC 230V/50Hz for Adapter  
 Test Specification: CHAMBER  
 Comment: Polarization: Vertical  
 Start of Test: Tem:25°C Hum:50%

**SWEEP TABLE: "test (1G-6G)"**

Short Description:		Field Strength				Transducer
Start Frequency	Stop Frequency	Detector	Meas. Time	IF Bandw.		
1.0 GHz	6.0 GHz	MaxPeak Average	Coupled	1 MHz		BBHA 9120 A

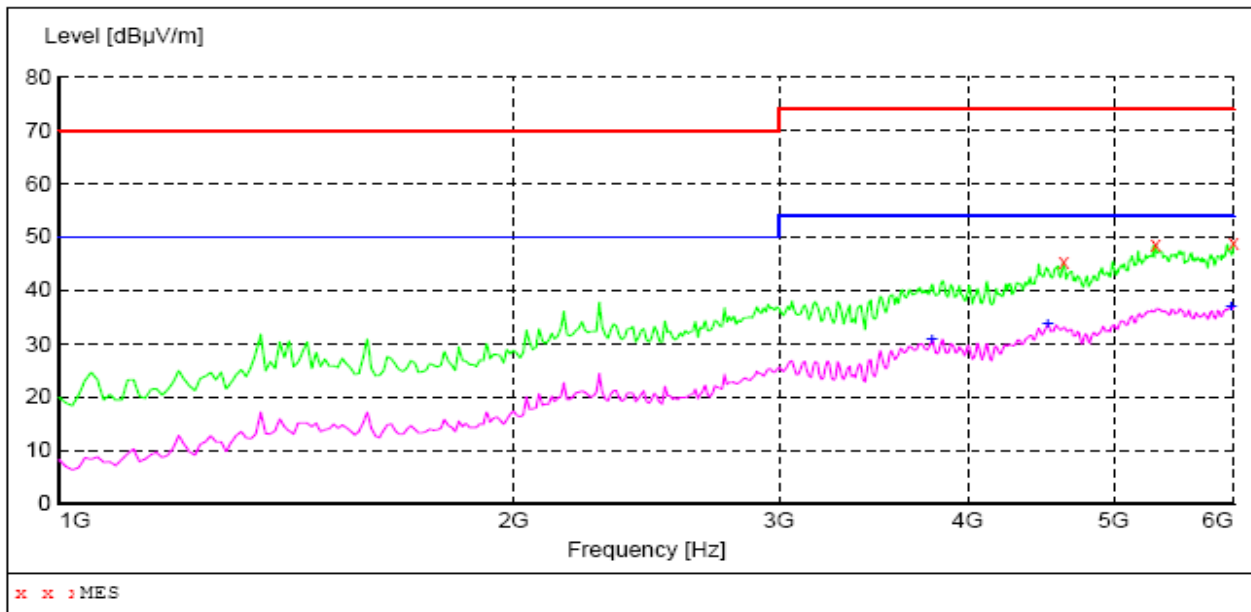

**MEASUREMENT RESULT:**

Frequency MHz	Level dBuV/m	Transd dB	Limit dBuV/m	Margin dB	Det.	Height cm	Azimuth deg	Polarization
4630.000000	45.20	0.4	74.0	28.8	PK	100.0	0.00	VERTICAL
5330.000000	48.40	3.2	74.0	25.6	PK	100.0	0.00	VERTICAL
6000.000000	48.90	4.2	74.0	25.1	PK	100.0	0.00	VERTICAL

**MEASUREMENT RESULT:**

Frequency MHz	Level dBuV/m	Transd dB	Limit dBuV/m	Margin dB	Det.	Height cm	Azimuth deg	Polarization
3790.000000	30.90	-2.7	54.0	23.1	AV	100.0	0.00	VERTICAL
4520.000000	33.60	0.1	54.0	20.4	AV	100.0	0.00	VERTICAL
5980.000000	36.90	4.2	54.0	17.1	AV	100.0	0.00	VERTICAL

### Radiated Emission Test Data of Above 1GHz

EUT: X3  
 M/N: X3P  
 Operating Condition: Normal operation  
 Test Site: 3m CHAMBER  
 Operator: Yang  
 Test Specification: AC 230V/50Hz for POE  
 Comment: Polarization: Horizontal  
 Start of Test: Tem:25°C Hum:50%

**SWEEP TABLE: "test (1G-6G)"**

Short Description:		Field Strength			
Start Frequency	Stop Frequency	Detector	Meas. Time	IF Bandw.	Transducer
1.0 GHz	6.0 GHz	MaxPeak Average	Coupled	1 MHz	BBHA 9120 A

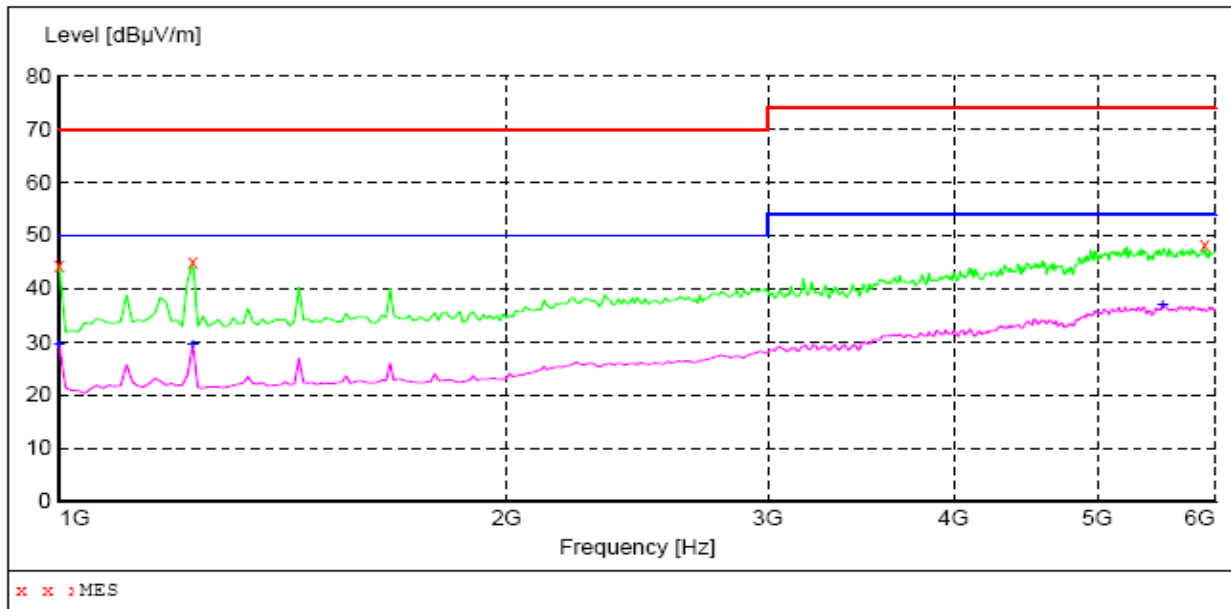

**MEASUREMENT RESULT:**

Frequency MHz	Level dBµV/m	Transd dB	Limit dBµV/m	Margin dB	Det.	Height cm	Azimuth deg	Polarization
1000.000000	44.30	-12.8	70.0	25.7	PK	100.0	0.00	HORIZONTAL
1230.000000	45.10	-11.7	70.0	24.9	PK	100.0	0.00	HORIZONTAL
5900.000000	48.30	4.1	74.0	25.7	PK	100.0	0.00	HORIZONTAL

**MEASUREMENT RESULT:**

Frequency MHz	Level dBµV/m	Transd dB	Limit dBµV/m	Margin dB	Det.	Height cm	Azimuth deg	Polarization
1000.000000	29.50	-12.8	50.0	20.5	AV	100.0	0.00	HORIZONTAL
1230.000000	29.40	-11.7	50.0	20.6	AV	100.0	0.00	HORIZONTAL
5530.000000	36.90	3.6	54.0	17.1	AV	100.0	0.00	HORIZONTAL

### Radiated Emission Test Data of Above 1GHz

EUT: X3  
 M/N: X3P  
 Operating Condition: 3m CHAMBER  
 Test Site: Yang  
 Operator: AC 230V/50Hz for POE  
 Test Specification: CHAMBER  
 Comment: Polarization: Vertical  
 Start of Test: Tem:25°C Hum:50%

**SWEEP TABLE: "test (1G-6G)"**

Start Frequency	Stop Frequency	Detector	Meas. Time	IF Bandw.	Field Strength	Transducer
1.0 GHz	6.0 GHz	MaxPeak Average	Coupled	1 MHz		BBHA 9120 A

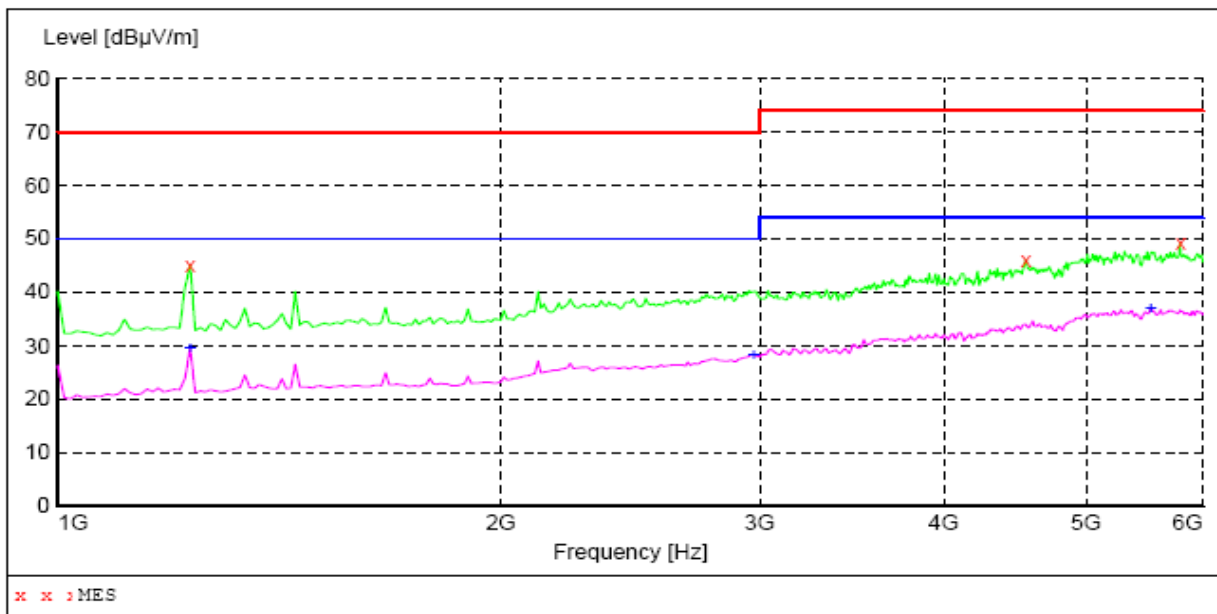

**MEASUREMENT RESULT :**

Frequency MHz	Level dBµV/m	Transd dB	Limit dBµV/m	Margin dB	Det.	Height cm	Azimuth deg	Polarization
1230.000000	45.10	-11.7	70.0	24.9	PK	100.0	0.00	VERTICAL
4550.000000	46.10	0.2	74.0	27.9	PK	100.0	0.00	VERTICAL
5790.000000	49.20	3.9	74.0	24.8	PK	100.0	0.00	VERTICAL

**MEASUREMENT RESULT :**

Frequency MHz	Level dBµV/m	Transd dB	Limit dBµV/m	Margin dB	Det.	Height cm	Azimuth deg	Polarization
1230.000000	29.50	-11.7	50.0	20.5	AV	100.0	0.00	VERTICAL
2970.000000	28.30	-6.0	50.0	21.7	AV	100.0	0.00	VERTICAL
5530.000000	37.00	3.6	54.0	17.0	AV	100.0	0.00	VERTICAL

## 6 - HARMONIC CURRENT TEST

### 6.1 Application of Harmonic Current Emission

Compliance to these standards ensures that tested equipment will not generate harmonic currents at levels that cause unacceptable degradation of the main environment. This directly contributes to meeting compatibility levels established in other EMC standards, which defines compatibility levels for low-frequency conducted disturbances in low-voltage supply systems.

### 6.2 Measurement Data

Note: For detailed test data, refer to the following pages:

Standard used:	EN 61000-3-2 A14 (2014) Quasi-stationary - Equipment class A
Observation time:	150s
E. U. T.:	X3
M/N	X3P
Operation Mode	Normal operation

### 6.3 Test Equipment List and Details

No.	Instrument no.	Equipment	Manufacturer	Model No.	S/N	Last Calculator	Due Calculator
1	BCT-EMC035	HARMONICS&FLICKR E ANALYSER	VOLTECH	PM6000	200006700433	2014-4-24	2015-4-23

### 6.4 Test Results

**Note:** The EUT's power is lower than 75W, this test isn't applicable.

## 7 - VOLTAGE FLUCTUATIONS AND FLICKER TEST

### 7.1 Application of Voltage Fluctuations and Flicker Test

Compliance to these standards ensures that tested equipment will not generate flickers and voltage change at levels that cause unacceptable degradation of the main environment. This directly contributes to meeting compatibility levels established in other EMC standards, which defines compatibility levels for low-frequency conducted disturbances in low-voltage supply systems.

### 7.2 Measurement Data

Note: For detailed test data, refer to the following pages:

Standard used:	EN 61000-3-3 Flicker
Short time (Pst):	10 min
Observation time:	10 min (1 Flicker measurement)
Flickermeter:	230V/50Hz
E. U. T.:	X3
M/N	X3P
Operation Mode	Normal operation

### 7.3 Test Equipment List and Details

No.	Instrument no.	Equipment	Manufacturer	Model No.	S/N	Last Calculator	Due Calculator
1	BCT-EMC035	HRMONICS&FLICKR E ANALYSER	VOLTECH	PM6000	200006700433	2014-4-24	2015-4-23

### 7.4 Test Results

Test Result	PASS
E. U. T.:	X3

### Maximum Flicker results

	Pst	dc (%)	dmax (%)	d(t) > 3.3%(ms)
Limit	1.000	3.300	4.000	500
Reading 1	0.095	0.003	0.488	0

## 8 - Electrostatic Discharge immunity Test

### 8.1 Block Diagram of Test Setup

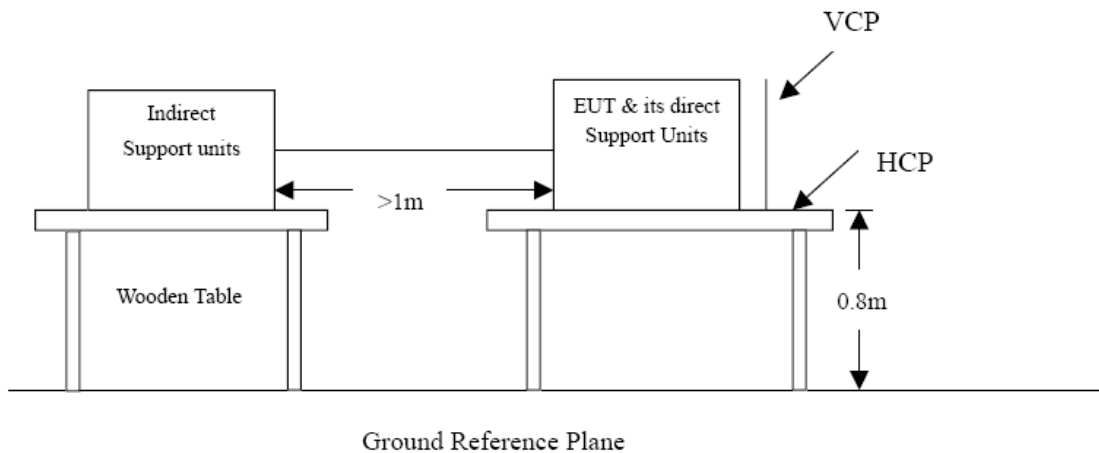

### 8.2 Test Standard

EN55024:2010 (EN 61000-4-2:2009 Severity Level: 3 / Air Discharge:  $\pm 8\text{KV}$  Level: 2 / Contact Discharge:  $\pm 4\text{KV}$ )

### 8.3 Severity Levels and Performance Criterion

#### 8.3.1 Severity level

Level	Test Voltage Contact Discharge (KV)	Test Voltage Air Discharge (KV)
1.	$\pm 2$	$\pm 2$
2.	$\pm 4$	$\pm 4$
3.	$\pm 6$	$\pm 8$
4.	$\pm 8$	$\pm 15$
X	Special	Special

#### 8.3.2 Performance criterion : B

### 8.4 Operating Condition of EUT

8.4.1 Setup the EUT as shown on Section 8.1.

8.4.2 Turn on the power of all equipments.

8.4.3 Let the EUT work in measuring mode (Normal operation) and measure it.

### 8.5 Test Procedure

#### 8.5.1 Air Discharge:

This test is done on a non-conductive surface. The round discharge tip of the discharge electrode shall be approached as fast as possible to touch the EUT. After each discharge, the discharge electrode shall be removed from the EUT. The generator is then re-triggered for a new single discharge and repeated 10 times for each pre-selected test point. This procedure shall be repeated until all the air discharge completed.

### 8.5.2 Contact Discharge:

All the procedure shall be same as Section 8.5.1. Except that the tip of the discharge electrode shall touch the EUT before the discharge switch is operated.

### 8.5.3 Indirect discharge for horizontal coupling plane

At least 10 single discharges (in the most sensitive polarity) shall be applied at the front edge of each HCP opposite the center point of each unit (if applicable) of the EUT and 0.1m from the front of the EUT. The long axis of the discharge electrode shall be in the plane of the HCP and perpendicular to its front edge during the discharge.

### 8.5.4 Indirect discharge for vertical coupling plane

At least 10 single discharge (in the most sensitive polarity) shall be applied to the center of one vertical edge of the coupling plane. The coupling plane, of dimensions 0.5m X 0.5m, is placed parallel to, and positioned at a distance of 0.1m from the EUT. Discharges shall be applied to the coupling plane, with this plane in sufficient different positions that the four faces of the EUT are completely illuminated.

## 8.6 Test Equipment List and Details

No.	Instrument no.	Equipment	Manufacturer	Model No.	S/N	Last Calculator	Due Calculator
1	BCT-EMC008	Electrostatic Discharge Simulator	TESEQ	NSG437	125	2014-4-24	2015-4-23

## 8.7 Test Results

**PASS**

Please refer to the following pages

Temperature ( °C )	22~24
Humidity ( %RH )	50~55
Barometric Pressure ( mbar )	950~1000
EUT	X3
M/N	X3P
Operating Mode	Normal operation

Table 1: Electrostatic Discharge Immunity (Air Discharge)

EN 61000-4-2 Test Points	Test Levels									
	-2 kV	+2 kV	-4 kV	+4 kV	-6 kV	+6 kV	-8 kV	+8 kV	-15 kV	+15 kV
Gap	A	A	A	A	A	A	A	A	/	/
Crust	A	A	A	A	A	A	A	A	/	/
Others	A	A	A	A	A	A	A	A	/	/

Table 2: Electrostatic Discharge Immunity (Direct Contact)

EN 61000-4-2 Test Points	Test Levels									
	-2 kV	+2 kV	-4 kV	+4 kV	-6 kV	+6 kV	-8 kV	+8 kV	-15 kV	+15 kV
Screw	A	A	A	A	/	/	/	/	/	/
Others	A	A	A	A	/	/	/	/	/	/

Table 3: Electrostatic Discharge Immunity (Indirect Contact HCP)

EN 61000-4-2 Test Points	Test Levels									
	-2 kV	+2 kV	-4 kV	+4 kV	-6 kV	+6 kV	-8 kV	+8 kV	-15 kV	+15 kV
Front Side	A	A	A	A	/	/	/	/	/	/
Back Side	A	A	A	A	/	/	/	/	/	/
Left Side	A	A	A	A	/	/	/	/	/	/
Right Side	A	A	A	A	/	/	/	/	/	/

Table 4: Electrostatic Discharge Immunity (Indirect Contact VCP)

EN 61000-4-2 Test Points	Test Levels									
	-2 kV	+2 kV	-4 kV	+4 kV	-6 kV	+6 kV	-8 kV	+8 kV	-15 kV	+15 kV
Front Side	A	A	A	A	/	/	/	/	/	/
Back Side	A	A	A	A	/	/	/	/	/	/
Left Side	A	A	A	A	/	/	/	/	/	/
Right Side	A	A	A	A	/	/	/	/	/	/

## 9 - RF Field Strength susceptibility TEST

### 9.1 Block Diagram of Test

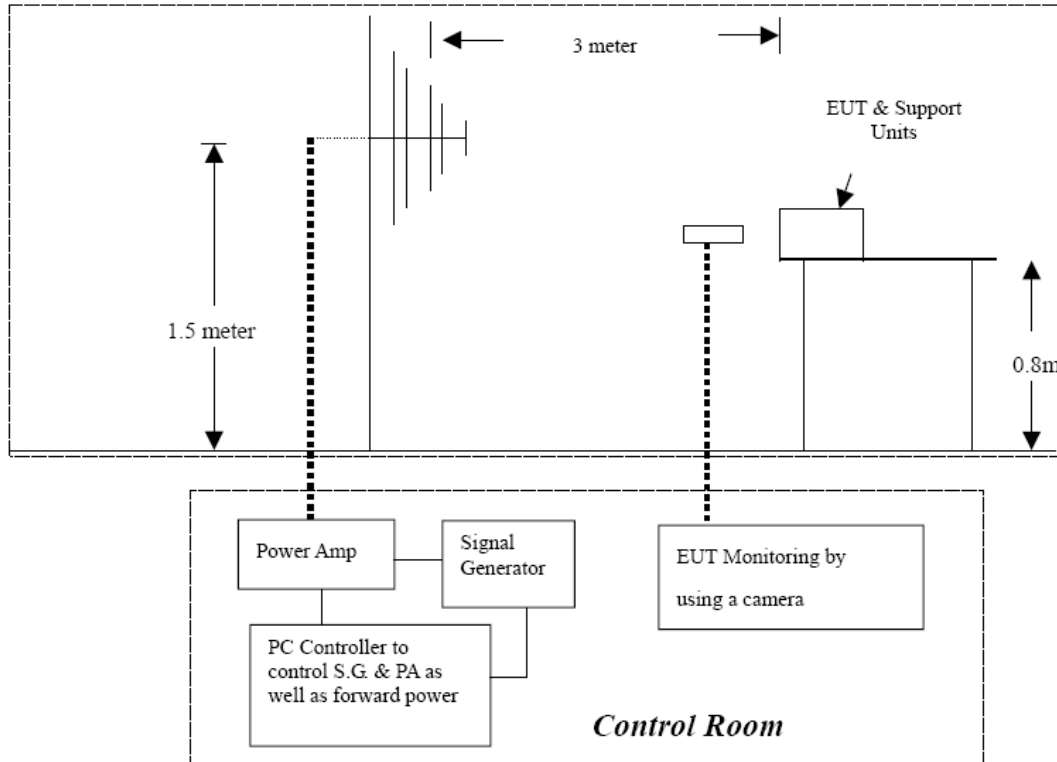

### 9.2 Test Standard

EN55024:2010 (EN 61000-4-3:2006+A2:2010, Severity Level: 2, 3V / m)

### 9.3 Severity Levels and Performance Criterion

#### 9.3.1 Severity Levels

Level	Field Strength V/m
1.	1
2.	3
3.	10
X	Special

#### 9.3.2 Performance Criterion: A

### 9.4 Operating Condition of EUT

9.4.1 Setup the EUT as shown on Section 9.1.

9.4.2 Turn on the power of all equipments.

9.4.3 Let the EUT work in measuring mode (Normal operation) and measure it..

### 9.5 Test Procedure

The EUT are placed on a table which is 0.8 meter high above the ground. The EUT is set 3 meters away from the transmitting antenna which is mounted on an antenna tower. Both horizontal and vertical polarization of the antenna are set on test. Each of the four sides of the EUT must be faced this transmitting antenna and measured individually.

In order to judge the EUT performance, a CCD camera is used to monitor its screen . All the scanning conditions are as following:

Condition of Test	Remark
1. Fielded Strength	3V/m (Severity Level 2)
2. Radiated Signal	Modulated
3. Scanning Frequency	80-1000MHz
4. Sweep time of radiated	0.0015 Decade/s
5. Dwell Time	1 Sec.

### 9.6 Test Equipment List and Details

No.	Equipment	Manufacturer	Model No.	S/N	Calibration Date	Next Calibration Date
1	3M Chamber & Accessory Equipment	ETS-LINDGREN	FACT-3	3510	07/07/2014	07/06/2015
2	ESG Vector signal generators	Agilent	E4438C	MY45095744	03/05/2014	03/04/2015
3	Power Amplifier	AR	150W1000	0322288	07/04/2014	07/03/2015
4	Power Amplifier	AR	25S1G4A	0321112	07/04/2014	07/03/2015
5	TRILOG Broadband Antenna	schwarzbeck	VULB 9136	401	07/04/2014	07/03/2015
6	Horn Antenna	ETS-LINGREN	3117	00057407	07/04/2014	07/03/2015
7	3M Chamber & Accessory Equipment	ETS-LINDGREN	FACT-3	3510	07/07/2014	07/06/2015
8	Spectrum Analyzer	Agilent	E4440A	MY46185649	03/05/2014	03/04/2015
9	TRILOG Broadband Antenna	schwarzbeck	VULB 9136	401	07/04/2014	07/03/2015
10	Multi device Controller	ETS-LINGREN	2090	00057230	N/A	N/A
11	Horn Antenna	ETS-LINGREN	3117	00057407	07/04/2014	07/03/2015
12	Microwave Preamplifier	Agilent	8449B	3008A02425	03/27/2014	03/26/2015

## 9.7 Test Results

**PASS**

Please refer to the following page.

Temperature ( °C )	22~24
Humidity ( %RH )	50~55
Barometric Pressure ( mbar )	950~1000
EUT	X3
M/N	X3P
Operating Mode	Normal operation

Frequency Range (MHz)	Front (3 V/m)		Rear (3 V/m)		Left Side (3 V/m)		Right Side (3 V/m)	
	VERT	HORI	VERT	HORI	VERT	HORI	VERT	HORI
80-1000	A	A	A	A	A	A	A	A



## 10 - Electrical Fast Transient/Burst Immunity Test

### 10.1 Block Diagram of Test Setup

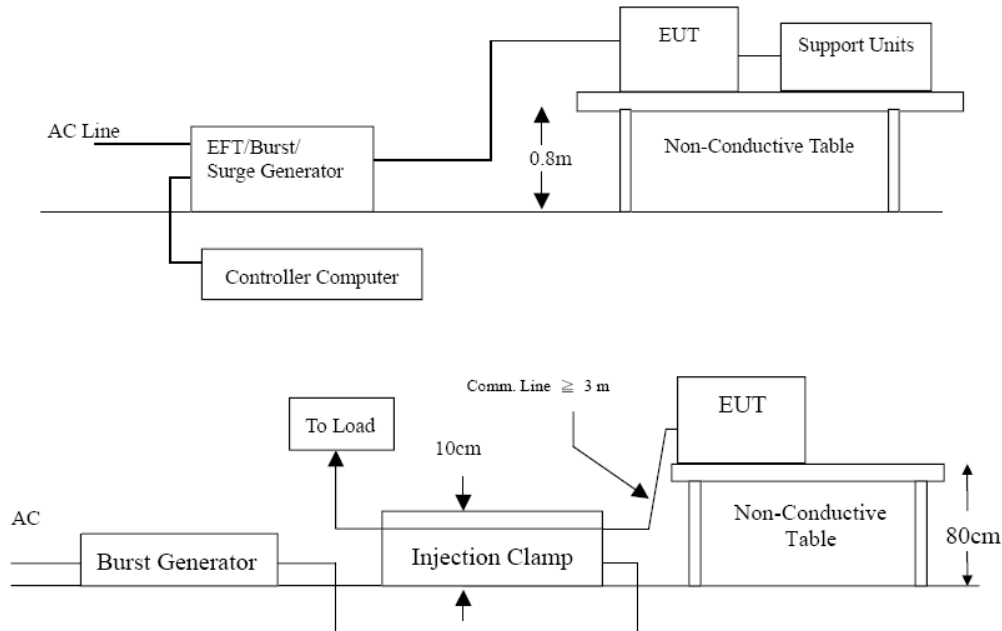

### 10.2 Test Standard

EN55024:2010 (EN61000-4-4:2012, Severity Level, Level 2: 1KV)

### 10.3 Severity Levels and Performance Criterion

#### 10.3.1 Severity level

Open Circuit Output Test Voltage $\pm 10\%$		
Level	On Power Supply Lines	On I/O (Input/Output) Signal data and control lines
1.	0.5 KV	0.25 KV
2.	1 KV	0.5 KV
3.	2 KV	1 KV
4.	4 KV	2 KV
X	Special	Special

#### 10.3.2 Performance criterion : B

### 10.4 Operating Condition of EUT

10.4.1 Setup the EUT as shown in Section 10.1.

10.4.2 Turn on the power of all equipments.

10.4.3 Let the EUT work in test mode (Normal operation) and measure it.

## 10.5 Test Procedure

The EUT is put on the table which is 0.8 meter high above the ground. This reference ground plane shall project beyond the EUT by at least 0.1m on all sides and the minimum distance between EUT and all other conductive structure, except the ground plane beneath the EUT, shall be more than 0.5m.

10.5.1 For input and output DC power ports:  
It's unnecessary to test

10.5.2 For signal lines and control lines ports:  
It's unnecessary to test.

10.5.3 For AC Input line ports:  
The EUT is connected to the AC power mains by using a coupling device which couples the EFT interference signal to AC power lines. Both polarities of the test voltage should be applied during compliance test and the duration of the test is 2 mins.

## 10.6 Test Equipment List and Details

No.	Instrument no.	Equipment	Manufacturer	Model No.	S/N	Last Calculator	Due Calculator
1	BCT-EMC009	Fast Transient Burst Generator	SCHAFFNER	MODULA6150	34572	2014-4-24	2015-4-23

## 10.7 Test Result

**PASS**

Please refer to the following page.

Temperature ( °C )	22~24
Humidity ( %RH )	50~55
Barometric Pressure ( mbar )	950~1000
EUT	X3
M/N	X3P
Operating Mode	Normal operation

EN 61000-4-4 Test Points		Test Levels (kV)							
		+0.5	-0.5	+1.0	-1.0	+2.0	-2.0	+4.0	-4.0
Power Supply	L1	A	A	A	A	/	/	/	/
	L2	A	A	A	A	/	/	/	/
	Earth	/	/	/	/	/	/	/	/
	L1+L2	A	A	A	A	/	/	/	/
Power Line of EUT	L1 + Earth	/	/	/	/	/	/	/	/
	L2 + Earth	/	/	/	/	/	/	/	/
	L1+L2+Earth	/	/	/	/	/	/	/	/
Network Port		A	A	/	/	/	/	/	/

## 11 - Surge Immunity Test

### 11.1 Block Diagram of Test Setup

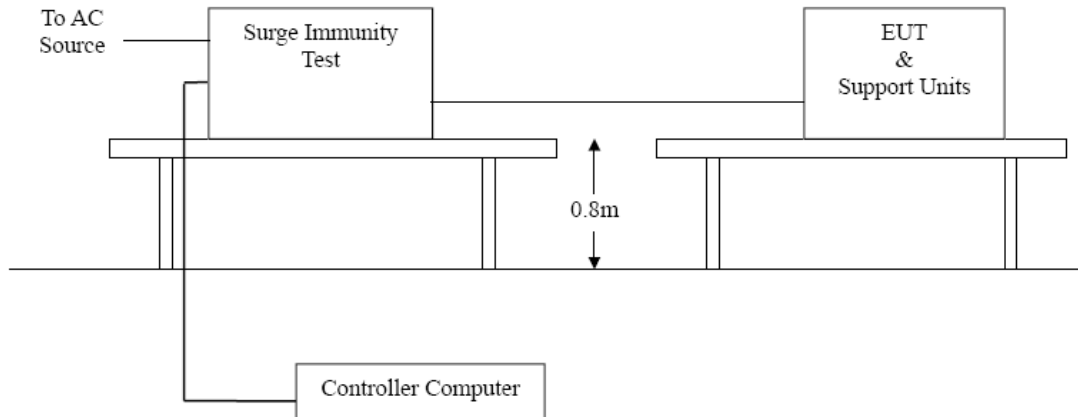

### 11.2 Test Standard

EN55024:2010 (EN61000-4-5:2014 Severity Level: Line to Line, Level 2: 1KV, Line to Earth , Level 3: 2KV, Signal line: Line to Earth, Level 2: 1KV)

### 11.3 Severity Levels and Performance Criterion

#### 11.3.1 Severity level

Severity Level	Open-Circuit Test Voltage KV
1	0.5
2	1.0
3	2.0
4	4.0
*	Special

#### 11.3.2 Performance criterion: B

### 11.4 Operating Condition of EUT

11.4.1 Setup the EUT as shown in Section 11.1.

11.4.2. Turn on the power of all equipments.

11.4.3. Let the EUT work in test mode (Normal operation) and measure it.

### 11.5 Test Procedure

- 1) Set up the EUT and test generator as shown on Section 11.1.
- 2) For DC port coupling mode, provide a 1 KV 1.2/50us voltage surge (at open-circuit condition) and 8/20us current surge to EUT selected points.
- 3) At least 5 positive and 5 negative (polarity) tests with a maximum 1/min repetition rate are conducted during test.
- 4) Record the EUT operating situation during compliance test and decide the EUT immunity criterion for above each test.

### 11.6 Test Equipment List and Details

No.	Instrument no.	Equipment	Manufacturer	Model No.	S/N	Last Calculator	Due Calculator
1	BCT-EMC009	Fast Transient Burst Generator	SCHAFFNER	MODULA6150	34572	2014-4-24	2015-4-23

### 11.7 Test Result

**PASS**

Please refer to the following page.

Temperature ( °C )	22~24
Humidity ( %RH )	50~55
Barometric Pressure ( mbar )	950~1000
EUT	X3
M/N	X3P
Operating Mode	Normal operation

Table 1: Surge Power Supply (AC POWER SUPPLY Power Line of EUT)

Level	Voltage	Poll	Path	Pass	Fail
1	0.5kV	±	L-N	A	/
2	1kV	±	L-N	A	/
3	2kV	±	L-PE, N-PE	/	/
4	4kV	±	L-N, L-PE, N-PE	/	/

Table 2: Surge Power Supply (Network Line of EUT)

Level	Voltage	Poll	Path	Pass	Fail
1	0.5kV	±	Line-gnd	A	/
2	1kV	±	Line-gnd	A	/

## 12 - Conducted Susceptibility Test

### 12.1 Block Diagram of Test Setup

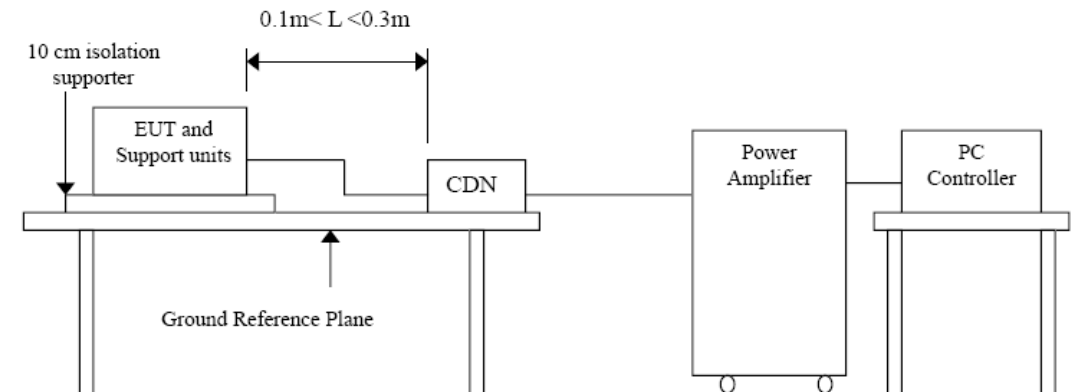

### 12.2 Test Standard

EN55024:2010 (EN61000-4-6:2014, Severity Level 2: 3V (rms)).(0.15MHz ~ 80MHz)

### 12.3 Severity Levels and Performance Criterion

#### 12.3.1 Severity level

Level	Field Strength V(rms)
1.	1
2.	3
3.	10
X	Special

#### 12.3.2 Performance criterion: A

### 12.4 Operating Condition of EUT

12.4.1 Setup the EUT as shown in Section 12.1.

12.4.2 Turn on the power of all equipments.

12.4.3 Let the EUT work in test mode (Normal operation) and measure it.

### 12.5 Test Procedure

12.5.1 For DC Mains  
It's unnecessary to test.

12.5.2 For signal lines and control lines ports:  
It's unnecessary to test.

### 12.5.3 For AC Input line ports:

- 1) Set up the EUT, CDN and test generators as shown on Section 12.1.
- 2) Let the EUT work in test mode and measure it.
- 3) The EUT are placed on an insulating support 0.1m high above a ground reference plane. CDN (coupling and decoupling network) is placed on the ground plane about 0.3m from EUT. Cables between CDN and EUT are as short as possible, and their height above the ground reference plane shall be between 30 and 50 mm (where possible).
- 4) The disturbance signal described below is injected to EUT through CDN.
- 5) The EUT operates within its operational mode(s) under intended climatic conditions after power on.
- 6) The frequency range is swept from 150KHz to 80MHz using 3V signal level, and with the disturbance signal 80% amplitude modulated with a 1KHz sine wave.
- 7) The rate of sweep shall not exceed  $1.5 \times 10^{-3}$  decades/s. Where the frequency is swept incrementally, the step size shall not exceed 1% of the start and thereafter 1% of the preceding frequency value.

Recording the EUT operating situation during compliance testing and decide the EUT immunity criterion.

### 12.6 Test Equipment List and Details

No.	Instrument no.	Equipment	Manufacturer	Model No.	S/N	Last Calculator	Due Calculator
1	BCT-EMC026	RF POWER AMPLIFIER	FRANKONIA	FLL-75	1020A1109	2014-4-24	2015-4-23
2	BCT-EMC027	CDN	FRANKONIA	CDN M2+M3	A3027019	2014-4-24	2015-4-23
3	BCT-EMC029	6DB Attenuator	FRANKONIA	N/A	1001698	2014-4-24	2015-4-23
4	BCT-EMC030	EM Injection clamp	FCC	F-203I-23mm	091536	2014-4-24	2015-4-23

### 12.7 Test Results

**PASS**

Please refer to the following page.

**Frequency Range (MHz):** 0.15~80MHz

**Modulation:** Amplitude 80%, 1kHz sinewave

**Severity Level:** 3Vr.m.s.

Temperature ( °C )	22~24
Humidity ( %RH )	50~55
Barometric Pressure ( mbar )	950~1000
EUT	X3
M/N	X3P
Operating Mode	Normal operation

Level	Voltage Level (e.m.f.) $U_0$	Pass	Fail
1	1	/	/
2	3	A	/
3	10	/	/
X	Special	/	/

Network Port

Level	Voltage Level (e.m.f.) $U_0$	Pass	Fail
1	1	/	/
2	3	A	/
3	10	/	/
X	Special	/	/



## 13 - Voltage Dips, Short Interruptions Immunity Tests

### 13.1 Block Diagram of Test Setup

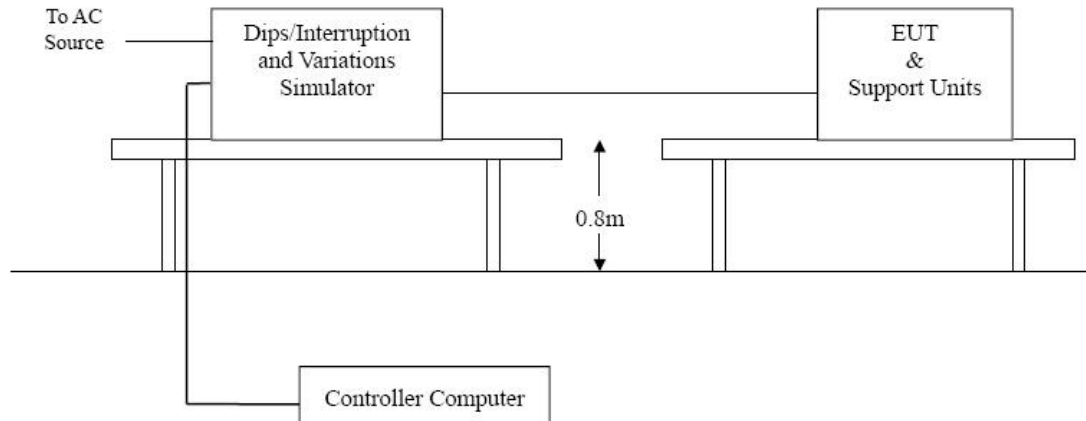

### 13.2 Test Standard

EN55024:2010 (EN61000-4-11:2004)

### 13.3 Severity Levels and Performance Criterion

#### 13.3.1 Severity level

Test Level %UT	Voltage dip and short interruptions %UT	Duration (in period)
0	100	0.5
40	60	1
70	30	5
		10
		25
		50
		*

#### 13.3.2 Performance criterion : B&C

### 13.4 EUT Configuration

The configuration of EUT is listed in Section 13.4.

### 13.5 Operating Condition of EUT

13.5.1 Turn on the power of all equipments.

13.5.2 Let the EUT work in test mode (Normal operation) and measure it.

### 13.6 Test Procedure

- 1) Set up the EUT and test generator as shown on Section 13.1.
- 2) The interruption is introduced at selected phase angles with specified duration.
- 3) Record any degradation of performance.

### 13.7 Test Equipment List and Details

No.	Instrument no.	Equipment	Manufacturer	Model No.	S/N	Last Calculator	Due Calculator
1	BCT-EMC009	Fast Transient Burst Generator	SCHAFFNER	MODULA6150	34572	2014-4-24	2015-4-23

### 13.8 Test Result

**PASS**

Please refer to the following page.

Temperature ( °C )	22~24
Humidity ( %RH )	50~55
Barometric Pressure ( mbar )	950~1000
EUT	X3
M/N	X3P
Operating Mode	Normal operation

Level	U2	td	Phase Angle	N	Pass	Fail
1	>95%	10ms	0/90/180/270	3	B	/
2	30%	500ms	0/90/180/270	3	C	/
3	>95%	5000ms	0/90/180/270	3	C	/

Note:

- A. The apparatus shall continue to operate as intended during and after the test. The manufacturer specifies some minimum performance level. The performance level may be specified by the manufacturer as a permissible loss of performance.
- B. The apparatus shall continue to operate as intended after the test. This indicates that the EUT does not need to function at normal performance levels during the test, but must recover. Again some minimal performance is defined by the manufacture. No change in operating state or loss or data is permitted.
- C. Temporary loss of function is allowed. Operation of the EUT may stop as long as it is either automatically reset or can be manually restored by operation of the controls.

## 14 - TEST RESULTS

---

The following tests were performed on the **Fanvil Technology Co., Ltd**'s product; model: **X3P**; the actual test results are contained within the Test Data section of this report.

### 14.1 EN 61000-4-2 Electrostatic Discharge Immunity Test Configuration

The EUT was subjected to the electrostatic discharge tests required by EN 55024 and all lower levels specified in EN 61000-4-2.

*The EUT continued to perform as intended during and after the application of the ESD. Test setup photographs presented in Appendix C.*

### 14.2 EN 61000-4-3 Radiated Susceptibility Test Configuration

The EUT was subjected to a 3-volt/meter, 80% Amplitude, 1 kHz Sine wave field as required by EN 55024 and all lower levels specified in EN 61000-4-3.

*The EUT continued to perform as intended during and after the application of the electromagnetic field. Test setup photographs presented in Appendix C.*

### 14.3 EN 61000-4-4 Electrical Fast Transient/Burst Immunity Test Configuration

The EUT was subjected to the electrical fast transient tests required by EN 55024 and all lower levels specified in EN 61000-4-4.

*The EUT continued to perform as intended during and after the application of the EFT/B. Test setup photographs presented in Appendix C.*

### 14.4 EN 61000-4-5 Surge Immunity Test Configuration

The EUT was subjected to the Surge Immunity tests required by EN 55024 and all lower levels specified in EN 61000-4-5.

*The EUT continued to perform as intended during and after the application of the Surge Immunity Test. Test setup photographs presented in Appendix C.*

### 14.5 EN 61000-4-6 Conducted Susceptibility Test Configuration

The EUT was subjected to the Conducted Susceptibility tests required by EN 55024 and all lower levels specified in EN 61000-4-6.

*The EUT continued to perform as intended during and after the application of the Conducted Susceptibility Test.*

### 14.6 EN 61000-4-11 Voltage Dips, Short Interruptions Immunity Tests Configuration

The EUT was subjected to the Voltage Dips/Interruptions tests required by EN 55024 and all lower levels specified in EN 61000-4-11.

*The EUT continued to perform as intended during and after the application of the Voltage Dips/Interruptions Test. Test setup photographs presented in Appendix C.*

## APPENDIX A - PRODUCT LABELING

### CE Marking Label Specification

Specification: Text is Black or white in color and is left justified. Labels are printed in indelible ink on permanent adhesive backing and shall be affixed at a conspicuous location on the EUT or silk-screened onto the EUT.



### Proposed Label Location on EUT

EUT Rear View/Proposed CE Marking Location



## APPENDIX B - EUT PHOTOGRAPHS

### EUT – Whole View



### EUT – Top View



### EUT – Bottom View



### EUT –Open View



### EUT –PCB View

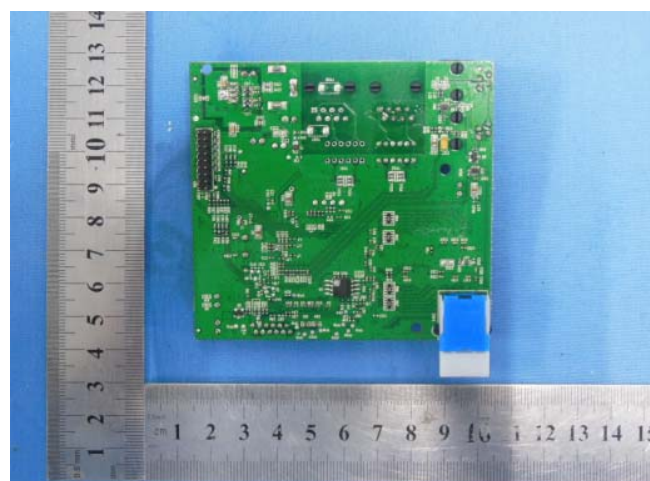
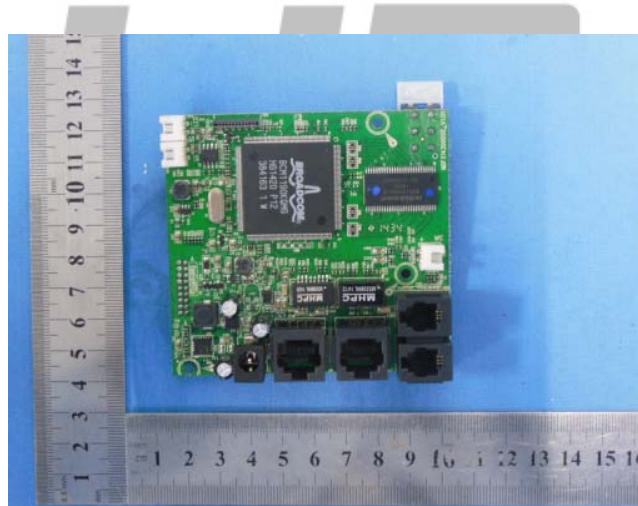

### EUT –PCB View

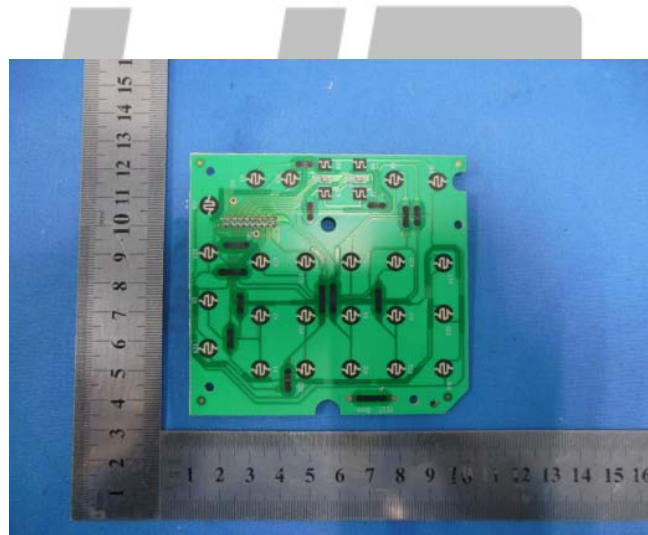
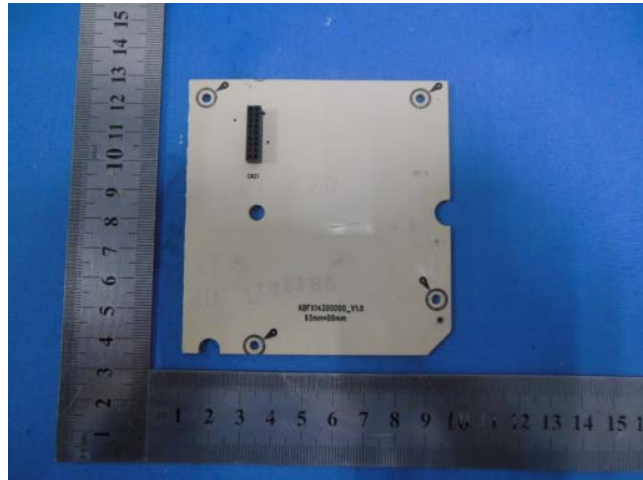

### EUT –Adapter View



## APPENDIX C - TEST SETUP PHOTOGRAPHS

### Conducted Emission



### Radiated Emission

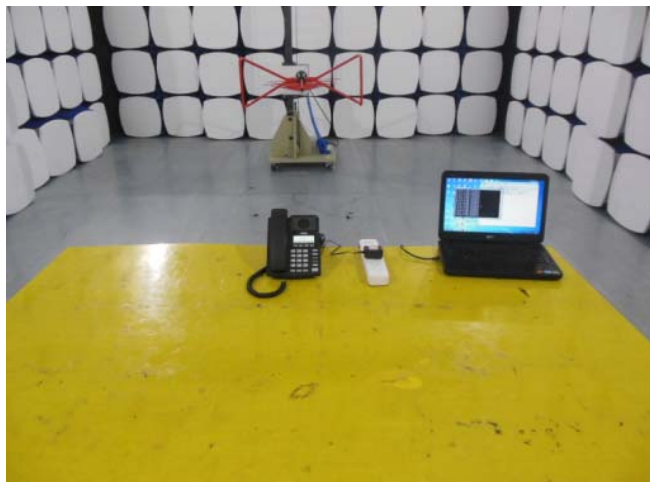

### Electrostatic Discharge Immunity Test



### Radiated Susceptibility Test

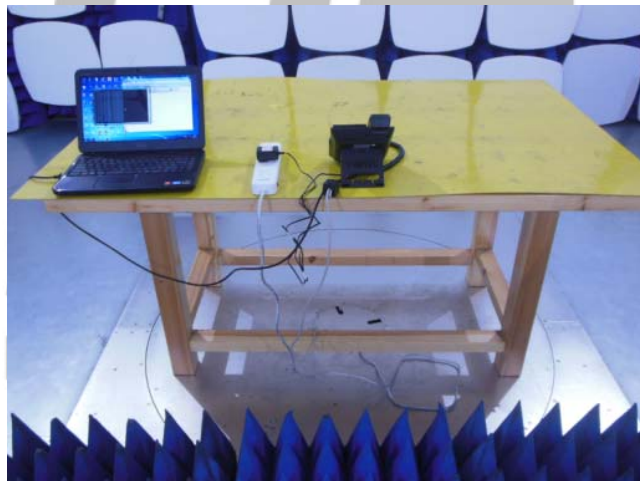

### Electrical Fast Transient/Surge Immunity Test for power port



### Electrical Fast Transient Immunity Test for LAN port



### Voltage Dips, Short Interruptions Immunity Test



### Conducted Susceptibility Test for power port



### Conducted Susceptibility Test for LAN port



### VOLTAGE FLUCTUATIONS AND FLICKER TEST

