

EMC Test Report

Project No. : 1610C139
Equipment : IP Phone
Test Model : H5
Series Model : H3
Applicant : Fanvil Technology Co.Ltd
Address : 3F, Block A, Gaoxinqi Building, Anhua Industrial Park,
Qianjin 1st Rd. 35th Dist., Bao'An, Shenzhen, 518101,
China

Date of Receipt : Oct. 18, 2016
Date of Test : Oct. 18, 2016 ~ Jan. 04, 2017
Issued Date : Jan. 06, 2017
Tested by : BTL Inc.

Testing Engineer : Kevin Li
(Kevin Li)

Technical Manager : Bill Zhang
(Bill Zhang)

Authorized Signatory : Steven Lu
(Steven Lu)

B T L I N C .

No.3, Jinshagang 1st Road, Shixia, Dalang Town, Dongguan,
Guangdong, China.

TEL: +86-769-8318-3000 FAX: +86-769-8319-6000



Declaration

BTL represents to the client that testing is done in accordance with standard procedures as applicable and that test instruments used has been calibrated with standards traceable to international standard(s) and/or national standard(s).

BTL's reports apply only to the specific samples tested under conditions. It is manufacture's responsibility to ensure that additional production units of this model are manufactured with the identical electrical and mechanical components. **BTL** shall have no liability for any declarations, inferences or generalizations drawn by the client or others from **BTL** issued reports.

BTL's report must not be used by the client to claim product certification, approval, or endorsement by NVLAP, NIST, or any agency of the Federal Government.

This report is the confidential property of the client. As a mutual protection to the clients, the public and **BTL-self**, extracts from the test report shall not be reproduced except in full with **BTL's** authorized written approval.

BTL's laboratory quality assurance procedures are in compliance with the **ISO Guide 17025** requirements, and accredited by the conformity assessment authorities listed in this test report.

Limitation

For the use of the authority's logo is limited unless the Test Standard(s)/Scope(s)/Item(s) mentioned in this test report is (are) included in the conformity assessment authorities acceptance respective.

Table of Contents**Page**

REPORT ISSUED HISTORY	6
1 . CERTIFICATION	7
2 . SUMMARY OF TEST RESULTS	8
2.1 TEST FACILITY	10
2.2 MEASUREMENT UNCERTAINTY	10
3 . GENERAL INFORMATION	12
3.1 GENERAL DESCRIPTION OF EUT	12
3.2 DESCRIPTION OF TEST MODES	13
3.3 EUT OPERATING CONDITIONS	14
3.4 BLOCK DIAGRAM SHOWING THE CONFIGURATION OF SYSTEM TESTED	14
3.5 DESCRIPTION OF SUPPORT UNITS	15
4 . EMC EMISSION TEST	16
4.1 RADIATED EMISSION	16
4.1.1 LIMITS	16
4.1.2 MEASUREMENT INSTRUMENTS LIST	18
4.1.3 TEST PROCEDURE	19
4.1.4 DEVIATION FROM TEST STANDARD	20
4.1.5 TEST SETUP	20
4.1.6 MEASUREMENT DISTANCE	21
4.1.7 TEST RESULTS (UP TO 1 GHZ)	22
4.1.8 TEST RESULTS (ABOVE 1 GHZ)	30
4.2 CONDUCTED EMISSION MEASUREMENT AT AC MAINS POWER PORTS	38
4.2.1 LIMITS	38
4.2.2 MEASUREMENT INSTRUMENTS LIST	38
4.2.3 TEST PROCEDURE	39
4.2.4 DEVIATION FROM TEST STANDARD	39
4.2.5 TEST SETUP	39
4.2.6 TEST RESULTS	40
4.3 ASYMMETRIC MODE CONDUCTED EMISSIONS TEST	44
4.3.1 LIMITS	44
4.3.2 MEASUREMENT INSTRUMENTS LIST	45
4.3.3 TEST PROCEDURE	45
4.3.4 DEVIATION FROM TEST STANDARD	45
4.3.5 TEST SETUP	46
4.3.6 TEST RESULTS	47
4.4 HARMONIC CURRENT EMISSIONS TEST	55
4.4.1 LIMITS	55
4.4.2 MEASUREMENT INSTRUMENTS LIST	55

Table of Contents	Page
4.4.3 TEST PROCEDURE	56
4.4.4 DEVIATION FROM TEST STANDARD	56
4.4.5 TEST SETUP	56
4.4.6 TEST RESULTS	57
4.5 VOLTAGE CHANGES, VOLTAGE FLUCTUATIONS AND FLICKER TEST	60
4.5.1 LIMITS	60
4.5.2 MEASUREMENT INSTRUMENTS LIST	60
4.5.3 TEST PROCEDURE	60
4.5.4 DEVIATION FROM TEST STANDARD	60
4.5.5 TESTSETUP	61
4.5.6 TEST RESULTS	62
5 . EMC IMMUNITY TEST	63
5.1 STANDARD COMPLIANCE/SEVERITY LEVEL/CRITERIA	63
5.2 GENERAL PERFORMANCE CRITERIA	65
5.3 ELECTROSTATIC DISCHARGE IMMUNITY TEST (ESD)	66
5.3.1 TEST SPECIFICATION	66
5.3.2 MEASUREMENT INSTRUMENTS	66
5.3.3 TEST PROCEDURE	66
5.3.4 DEVIATION FROM TEST STANDARD	67
5.3.5 TEST SETUP	67
5.3.6 TEST RESULTS	68
5.4 RADIATED, RADIO-FREQUENCY, ELECTROMAGNETIC FIELD IMMUNITY TEST (RS)	73
5.4.1 TEST SPECIFICATION	73
5.4.2 MEASUREMENT INSTRUMENTS	73
5.4.3 TEST PROCEDURE	73
5.4.4 DEVIATION FROM TEST STANDARD	73
5.4.5 TEST SETUP	74
5.4.6 TEST RESULTS	75
5.5 ELECTRICAL FAST TRANSIENT/BURST IMMUNITY TEST (EFT/BURST)	76
5.5.1 TEST SPECIFICATION	76
5.5.2 MEASUREMENT INSTRUMENTS	76
5.5.3 TEST PROCEDURE	76
5.5.4 DEVIATION FROM TEST STANDARD	76
5.5.5 TEST SETUP	77
5.5.6 TEST RESULTS	78
5.6 SURGE IMMUNITY TEST	79
5.6.1 TEST SPECIFICATION	79
5.6.2 MEASUREMENT INSTRUMENTS	79
5.6.3 TEST PROCEDURE	80
5.6.4 DEVIATION FROM TEST STANDARD	80

Table of Contents	Page
5.6.5 TEST SETUP	80
5.6.6 TEST RESULTS	81
5.7 IMMUNITY TO CONDUCTED DISTURBANCES, INDUCED BY	
RADIO-FREQUENCY FIELDS TEST (CS)	82
5.7.1 TEST SPECIFICATION	82
5.7.2 MEASUREMENT INSTRUMENTS	82
5.7.3 TEST PROCEDURE	82
5.7.4 DEVIATION FROM TEST STANDARD	82
5.7.5 TEST SETUP	83
5.7.6 TEST RESULTS	84
5.8 POWER FREQUENCY MAGNETIC FIELD IMMUNITY TEST (PFMF)	85
5.8.1 TEST SPECIFICATION	85
5.8.2 MEASUREMENT INSTRUMENTS	85
5.8.3 TEST PROCEDURE	85
5.8.4 DEVIATION FROM TEST STANDARD	85
5.8.5 TEST SETUP	86
5.8.6 TEST RESULTS	87
5.9 VOLTAGE DIPS, SHORT INTERRUPTIONS AND VOLTAGE VARIATIONS	
IMMUNITY TEST	88
5.9.1 TEST SPECIFICATION	88
5.9.2 MEASUREMENT INSTRUMENTS	88
5.9.3 TEST PROCEDURE	88
5.9.4 DEVIATION FROM TEST STANDARD	88
5.9.5 TEST SETUP	89
5.9.6 TEST RESULTS	90

REPORT ISSUED HISTORY

Issued No.	Description	Issued Date
BTL-EMC-1-1610C139	Original Issue.	Jan. 06, 2017

1. CERTIFICATION

Equipment : IP Phone
Brand Name : Fanvil
Test Model : H5
Series Model : H3
Applicant : Fanvil Technology Co.Ltd
Manufacturer : Fanvil Technology Co.Ltd
Address : 3F, Block A, Gaoxinqi Building, Anhua Industrial Park, Qianjin 1st Rd. 35th
Dist., Bao'An, Shenzhen, 518101, China
Factory : Fanvil Technology Co.Ltd
Address : 3F, Block A, Gaoxinqi Building, Anhua Industrial Park, Qianjin 1st Rd. 35th
Dist., Bao'An, Shenzhen, 518101, China
Date of Test : Oct. 18, 2016 ~ Jan. 04, 2017
Test Sample : Engineering Sample
Standard(s) : EN 55032: 2012+AC:2013 Class B
EN 61000-3-2: 2014 Class A
EN 61000-3-3: 2013
EN 55024: 2010+A1:2015
EN 61000-4-2: 2009
EN 61000-4-3: 2006+A1:2008+A2:2010
EN 61000-4-4: 2012
EN 61000-4-5: 2014
EN 61000-4-6: 2014+AC : 2015
EN 61000-4-8: 2010
EN 61000-4-11: 2004

The above equipment has been tested and found compliance with the requirement of the relative standards by BTL Inc.

The test data, data evaluation, and equipment configuration contained in our test report (Ref No. BTL-EMC-1-1610C139) were obtained utilizing the test procedures, test instruments, test sites that has been accredited by the Authority of TAF according to the ISO-17025 quality assessment standard and technical standard(s).

2. SUMMARY OF TEST RESULTS

Test procedures according to the technical standards:

Emission					
Standard(s)	Test Item	Limit	Judgment	Remark	
EN 55032: 2012+AC:2013	Radiated emissions up to 1 GHz	Class B	PASS	-----	
	Radiated emissions above 1 GHz	Class B	PASS	NOTE (2)	
	Radiated emissions from FM receivers	-----	N/A	NOTE (1) NOTE (6)	
	Conducted emissions AC mains power port	Class B	PASS	NOTE (7)	
	Asymmetric mode conducted emissions	AAN	-----	PASS	NOTE (1) NOTE (8)
		Current Probe	-----	N/A	
		CVP	-----	N/A	
Conducted differential voltage emissions	-----	N/A	NOTE (1) NOTE (9)		

Standard	Test Item	Limit	Judgment	Remark
EN 61000-3-2:2014	Harmonic current emissions	Class A	PASS	NOTE (3)
EN 61000-3-3:2013	Voltage changes, voltage fluctuations and flicker		PASS	

Immunity EN 55024: 2010+A1:2015				
Section(s)	Test Item	Performance Criterion	Judgment	Remark
EN 61000-4-2:2009	Electrostatic discharge immunity	B	PASS	
EN 61000-4-3: 2006+A1:2008+A2:2010	Radiated, radio-frequency, electromagnetic field immunity	A	PASS	
EN 61000-4-4:2012	Electrical fast transient/burst immunity	B	PASS	
EN 61000-4-5:2014	Surge immunity	B/C	PASS	NOTE (4)
EN 61000-4-6: 2014+AC :2015	Immunity to conducted disturbances, induced by radio-frequency fields	A	PASS	
EN 61000-4-8:2010	Power frequency magnetic field immunity	A	PASS	
EN 61000-4-11:2004	Voltage dips, short interruptions and voltage variations immunity	B / C / C	PASS	NOTE (5)

NOTE:

- (1) "N/A" denotes test is not applicable to this device.
- (2) The EUT's max operating frequency is 166 MHz which does exceed 108 MHz, so the test will be performed.
- (3) If the power consumption is less than 75W, there is no limit applied.
- (4) Performance Criterion C for signal ports and telecommunication ports.
Performance Criterion B for input d.c. power port and a.c. power ports.
- (5) Voltage Dips: >95% reduction – Performance Criterion B
Voltage Dips: 30% reduction – Performance Criterion C
Voltage Interruptions: >95% reduction – Performance Criterion C
- (6) If the EUT has FM function the test will be performed.
- (7) If the EUT has AC power mains port the test will be performed.
- (8)

Cable Type	Number of pairs	Measurement type	Procedures
Balanced Unscreened	1 (2 wire) ;2 (4 wire); 3 (6 wire) ;4 (8 wire)	Voltage	AAN
Balanced Unscreened	See a)	Voltage and Current	CP+CVP
Screened or Coaxial	n/a	Voltage	AAN
Screened or Coaxial	n/a	Voltage or Current	CP or CVP
Unbalanced cables	n/a	Voltage and Current	CP+CVP

Ports connected to cables with more than 4 balanced pairs or where the port is unable to function correctly when connected through an AAN.

- (9) If the EUT has tuner port the test will be performed.
- (10) The requirement followed by the client's specification.

2.1 TEST FACILITY

The test facilities used to collect the test data in this report is at the location of No.3, Jinshagang 1st Road, Shixia, Dalang Town, Dongguan, Guangdong, China.

The test facilities used to collect the test data in this report is at the location of No. 68-1, Ln. 169, Sec.2, Datong Rd., Xizhi Dist., New Taipei City 221, Taiwan

2.2 MEASUREMENT UNCERTAINTY

Where relevant, the following measurement uncertainty levels have been estimated for tests performed on the EUT as specified in CISPR 16-4-2, The BTL measurement uncertainty is less than the CISPR 16-4-2 U_{cispr} requirement.

The reported uncertainty of measurement $y \pm U$, where expanded uncertainty U is based on a standard uncertainty multiplied by a coverage factor of $k=2$, providing a level of confidence of approximately 95%.

A. Conducted emissions AC mains power port measurement:

Test Site	Method	Measurement Frequency Range	U, (dB)
DG-C01	CISPR	150 kHz ~ 30MHz	3.16

B. Conducted disturbance at telecommunication port measurement:

Test Site	Method	Measurement Frequency Range	U, (dB)
DG-C01	CISPR	AAN 50...40dB	3.76
		AAN 65...50dB	3.76
		AAN 75...60dB	3.76
		Capacitive Voltage Probe	3.04
		RF Current Probe	2.58

C. Radiated emissions up to 1 GHz measurement:

Test Site	Method	Measurement Frequency Range	Ant. H / V	U, (dB)
DG-CB08 (10m)	CISPR	30MHz ~ 200MHz	V	4.66
		30MHz ~ 200MHz	H	4.64
		200MHz ~ 1,000MHz	V	4.88
		200MHz ~ 1,000MHz	H	4.86

D. Radiated emissions above 1 GHz measurement:

Test Site	Method	Measurement Frequency Range	U, (dB)
DG-CB08 (3m)	CISPR	1 ~ 6 GHz	4.26
		6 ~ 18 GHz	5.30

E. Harmonic current emissions / Voltage changes, voltage fluctuations and flicker measurement:

Test Site	Method	Measurement Frequency Range	U, (dB)
DG-C01	EN 61000-3-2	Voltage	0.774
	EN 61000-3-3	Current	0.782

F. Immunity Measurement:

Test Site	Method	Measurement Frequency Range	U, (dB)
DG-SR02	EN 61000-4-2	Voltage(2kV/4kV/6kV/8kV/15kV/25kV/30kV)	1.0%
		Peak Current	6.0%
		30/60ns Current	6.0%
		Rise time	6.4%
DG-CB05	EN 61000-4-3	80MHz~1GHz	2.175 dB
DG-SR05	EN 61000-4-4	Impulse Voltage	4.0 %
		Impulse Rise Time	4.5 %
		Impulse duration Time	4.0 %
DG-SR05	EN 61000-4-5	Impulse Voltage	4.0 %
		Impulse Rise Time	4.5 %
		Impulse duration Time	4.0 %
DG-CB06	EN 61000-4-6	CDN: 150kHz~230MHz	2.509 dB
		EM Clamp: 150kHz~230MHz	3.094 dB
DG-SR05	EN 61000-4-8	Magnetic Field Level	3 %
DG-SR05	EN 61000-4-11	Impulse Amplitude	4 %
		Timing	3 %

Note: Unless specifically mentioned, the uncertainty of measurement has not been taken into account to declare the compliance or non-compliance to the specification.

3. GENERAL INFORMATION

3.1 GENERAL DESCRIPTION OF EUT

Equipment	IP Phone
Brand Name	Fanvil
Test Model	H5
Series Model	H3
Model Difference	Only differ in panel
Power Source	1# DC Voltage supplied from AC/DC adapter. Manufacturer: SHENZHEN FRECOM ELECTRONICS CO.,LTD. Model: F05L5-050100SPAV L.P.S 2# Supplied from PoE
Power Rating	1# I/P:100-240V~50/60Hz 0.2A O/P: 5V---1A 2# PoE 48V

Note:

1. For a more detailed features description, please refer to the manufacturer's specifications or the user's manual.

3.2 DESCRIPTION OF TEST MODES

To investigate the maximum EMI emission characteristics generates from EUT, the test system was pre-scanning tested base on the consideration of following EUT operation mode or test configuration mode which possible have effect on EMI emission level. Each of these EUT operation mode(s) or test configuration mode(s) mentioned above was evaluated respectively.

Pretest Mode	Description
Mode 1	Handfree
Mode 2	Handset
Mode 3	LAN 100Mbps
Mode 4	LAN 10Mbps
Mode 5	WAN 100Mbps
Mode 6	WAN 10Mbps

For Radiated Test	
Final Test Mode	Description
Mode 1	Handfree
Mode 2	Handset

For Conducted Test	
Final Test Mode	Description
Mode 1	Handfree
Mode 2	Handset

For ISN Test	
Final Test Mode	Description
Mode 3	LAN 100Mbps
Mode 4	LAN 10Mbps
Mode 5	WAN 100Mbps
Mode 6	WAN 10Mbps

For Harmonics / Flicks Test	
Final Test Mode	Description
Mode 1	Handfree

For EMS Test	
Final Test Mode	Description
Mode 1	Handfree
Mode 2	Handset

3.3 EUT OPERATING CONDITIONS

The EUT exercise program used during radiated and/or conducted emission measurement was designed to exercise the various system components in a manner similar to a typical use.

3.4 BLOCK DIAGRAM SHOWING THE CONFIGURATION OF SYSTEM TESTED

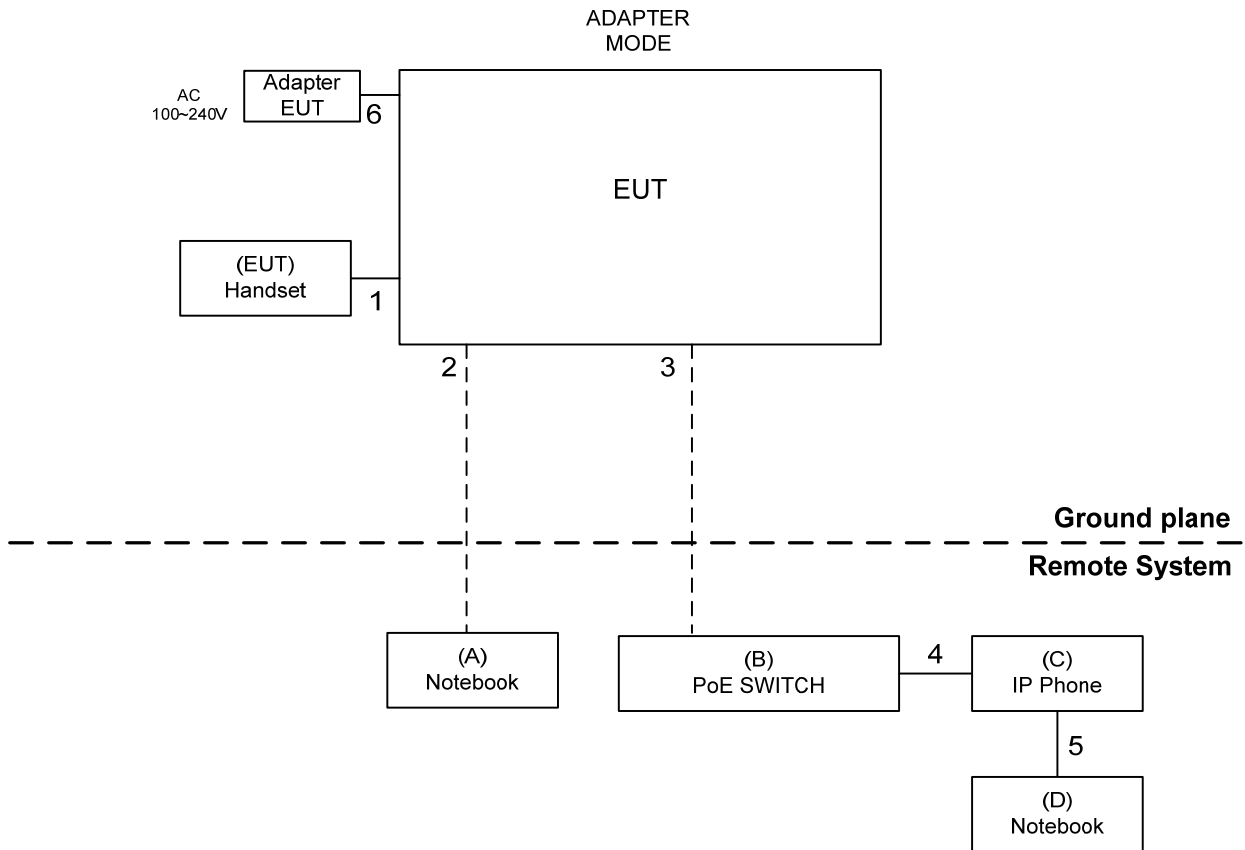

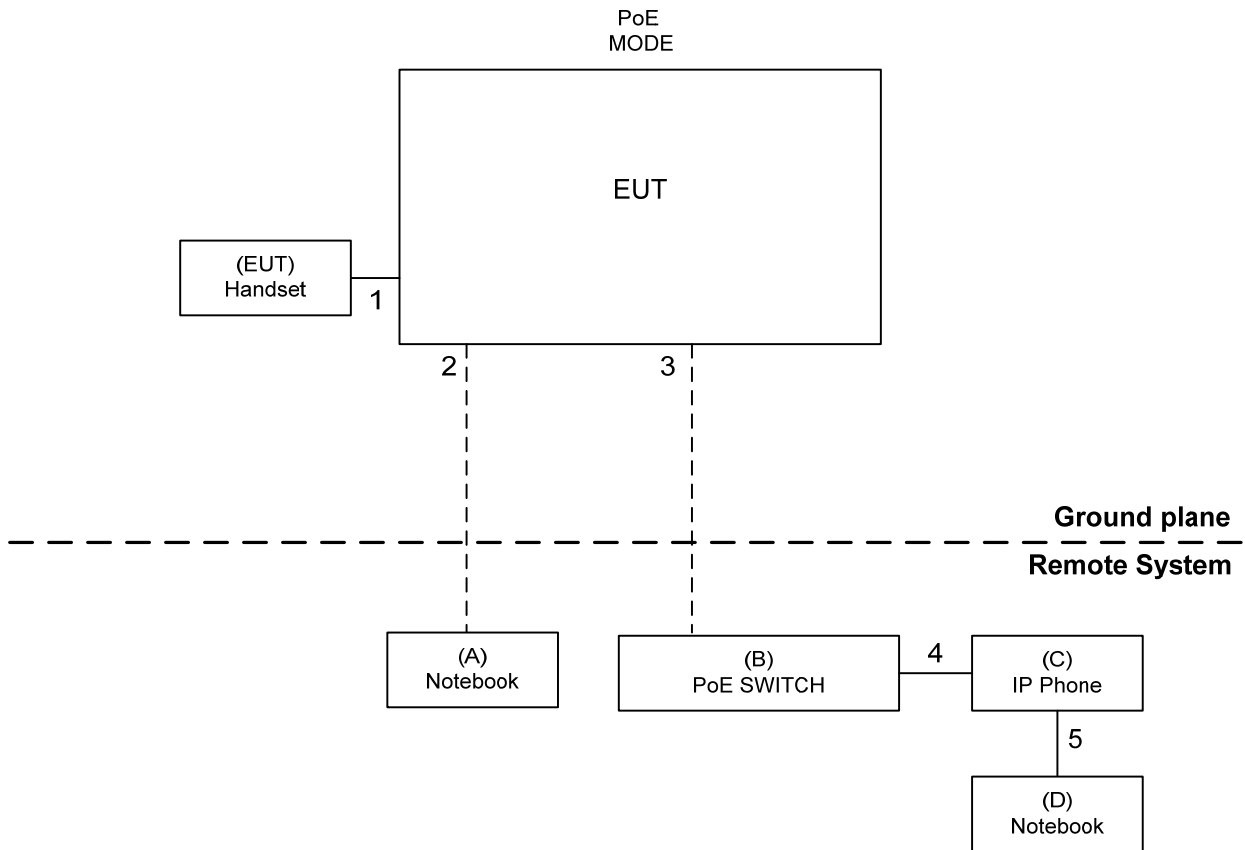

3.5 DESCRIPTION OF SUPPORT UNITS

The EUT has been tested as an independent unit together with other necessary accessories or support units. The following support units or accessories were used to form a representative test configuration during the tests.

Item	Equipment	Mfr/Brand	Model/Type No.	FCC ID	Series No.
A	Notebook	DELL	INSPIRON 1420	DOC	JX193A01SDC2
B	PoE SWITCH	D-LINK	DGS-1008P	N/A	QB842D1000045
C	IP PHONE	FANVIL	X3P	N/A	N/A
D	Notebook	HP	8460P	DOC	CNU1301BJ3

Item	Shielded Type	Ferrite Core	Length	Note
1	NO	NO	1.8m	RJ11 Cable
2	NO	NO	15m	RJ45 Cable
3	NO	NO	15m	RJ45 Cable
4	NO	NO	1m	RJ45 Cable
5	NO	NO	1m	RJ45 Cable
6	NO	NO	1.8m	DC Cable

4. EMC EMISSION TEST

4.1 RADIATED EMISSION

4.1.1 LIMITS

Class A equipment up to 1000MHz

Table clause	Frequency MHz	Measurement		Class A limit dB(uV/m)
		Distance m	Detector type/bandwidth	OATS/SAC
A2.1	30-230	10	Quasi peak / 120 kHz	40
	230-1000			47
A2.2	30-230	3		50
	230-1000			57

Class A equipment above 1000MHz

Table clause	Frequency MHz	Measurement		Class A limit dB(uV/m)
		Distance m	Detector type/bandwidth	FSOATS
A3.1	1000-3000	3	Average / 1 MHz	56
	3000-6000			60
A3.2	1000-3000		Peak / 1 MHz	76
	3000-6000			80

Class B equipment up to 1000MHz

Table clause	Frequency MHz	Measurement		Class B limit dB(uV/m)
		Distance m	Detector type/bandwidth	OATS/SAC
A4.1	30-230	10	Quasi peak / 120 kHz	30
	230-1000			37
A4.2	30-230	3		40
	230-1000			47

Class B equipment above 1000MHz

Table clause	Frequency MHz	Measurement		Class B limit dB(uV/m)
		Distance m	Detector type/bandwidth	FSOATS
A5.1	1000-3000	3	Average / 1 MHz	50
	3000-6000			54
A5.2	1000-3000		Peak / 1 MHz	70
	3000-6000			74

Notes:

- (1) The limit for radiated test was performed according to as following: EN 55032
- (2) The tighter limit applies at the band edges.
- (3) Emission level (dBuV/m)=20log Emission level (uV/m).
- (4) The test result calculated as following:
 Measurement Value = Reading Level + Correct Factor
 Correct Factor = Antenna Factor + Cable Loss - Amplifier Gain(if use)
 Margin Level = Measurement Value - Limit Value

Required highest frequency for radiated measurement

Highest internal frequency (F_x) MHz	Highest measured frequency MHz
$F_x \leq 108$	1000
$108 < F_x \leq 500$	2000
$500 < F_x \leq 1000$	5000
$F_x > 1000$	5 th up to a maximum 6 GHz,

Note for FM and TV broadcast receiver, F_x is determined from the highest frequency generated or used excluding the local oscillator and tuned frequencies.

4.1.2 MEASUREMENT INSTRUMENTS LIST

Up to 1GHz:

Item	Kind of Equipment	Manufacturer	Type No.	Serial No.	Calibrated until
1	Pre-Amplifier	Mini-Circuits	EMC 9135	980284	Mar. 27, 2017
2	Pre-Amplifier	Mini-Circuits	EMC 9135	980283	Mar. 27, 2017
3	Trilog-Broadband Antenna	Schwarzbeck	VULB9168	586	Feb. 04, 2017
4	Trilog-Broadband Antenna	Schwarzbeck	VULB9168	587	Jan. 26, 2017
5	Cable	emci	LMR-400(5m +11m+15m)	N/A	Dec. 31, 2016
6	Cable	emci	LMR-400(5m +8m+15m)	N/A	Dec. 31, 2016
7	Measurement Software	Farad	EZ-EMC Ver.BTL-2AN T-1	N/A	N/A
8	Multi-Device Controller	ETS-Lindgren	2090	N/A	N/A
9	Receiver	Keysight	N9038A	MY54450004	Sep. 04, 2017

Remark: "N/A" denotes no model name, no serial no. or no calibration specified.
All calibration period of equipment list is one year.

Above 1GHz:

Item	Kind of Equipment	Manufacturer	Type No.	Serial No.	Calibrated until
1	Measurement Software	Farad	EZ-EMC Ver.BTL-2ANT-1	N/A	N/A
2	Cable	emci	SUCOFLEX_15 m_5m(0.01GHz -26.5GHz)	N/A	Dec. 27, 2017
3	Multi-Device Controller	ETS-Lindgren	2090	N/A	N/A
4	Controller	MF	MF-7802	MF780208159	N/A
5	Cable	emci	SUCOFLEX 102_8m(0.01GHz -40GHz)	N/A	Mar. 27, 2017
6	Horn Antenna	EMCO	3115	9605-4803	Mar. 27, 2017

Remark: "N/A" denotes no model name, no serial no. or no calibration specified.
All calibration period of equipment list is one year.

4.1.3 TEST PROCEDURE

- a. The measuring distance of 10 m shall be used for measurements. The EUT was placed on the top of a rotating table 0.8 meter above the ground at a 10 meter semi-anechoic chamber. The table was rotated 360 degrees to determine the position of the highest radiation.(below 1GHz).
- b. The measuring distance of 3 m shall be used for measurements. The EUT was placed on the top of a rotating table 0.8 meter above the ground at a 10 meter semi-anechoic chamber. The table was rotated 360 degrees to determine the position of the highest radiation.(above 1GHz)
- c. The height of the equipment or of the substitution antenna shall be 0.8 m, the height of the test antenna shall vary between 1 m to 4 m. Both horizontal and vertical polarizations of the antenna are set to make the measurement.
- d. The initial step in collecting radiated emission data is a receiver peak detector mode pre-scanning the measurement frequency range. Significant peaks are then marked and then Quasi Peak detector mode re-measured.
- e. All readings are Peak unless otherwise stated QP in column of Note. Peak denotes that the Peak reading compliance with the QP Limits and then QP Mode measurement didn't perform. (below 1GHz)
- f. All readings are Peak Mode value unless otherwise stated AVG in column of Note. If the Peak Mode Measured value compliance with the Peak Limits and lower than AVG Limits, the EUT shall be deemed to meet both Peak & AVG Limits and then only Peak Mode was measured, but AVG Mode didn't perform. (above 1GHz)
- g. For the actual test configuration, please refer to the related Item - Block Diagram of system tested (please refer to 3.3).

4.1.4 DEVIATION FROM TEST STANDARD

No deviation

4.1.5 TEST SETUP

UP TO 1 GHZ

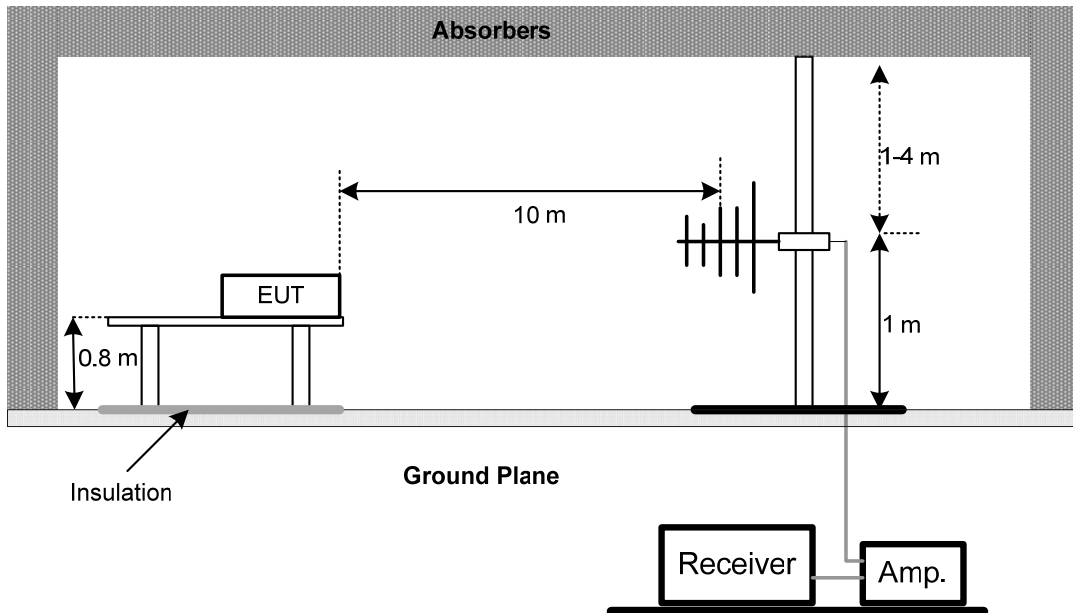

Note: The antenna can be moved between 1 to 4 meters above the ground.

ABOVE 1 GHZ

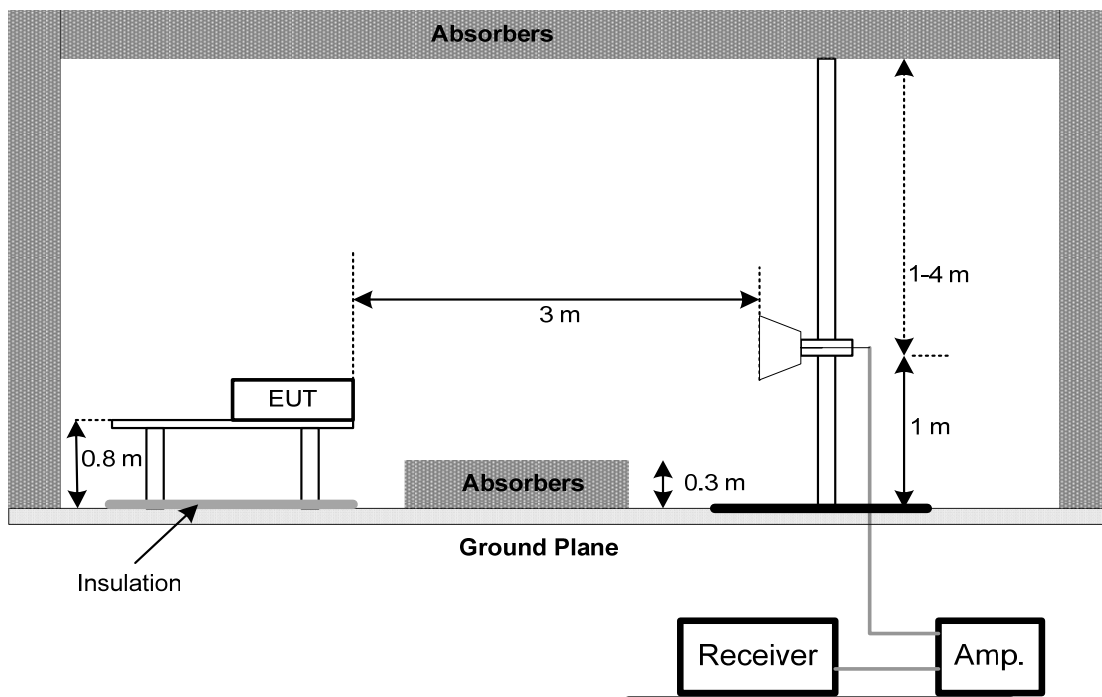

4.1.6 MEASUREMENT DISTANCE

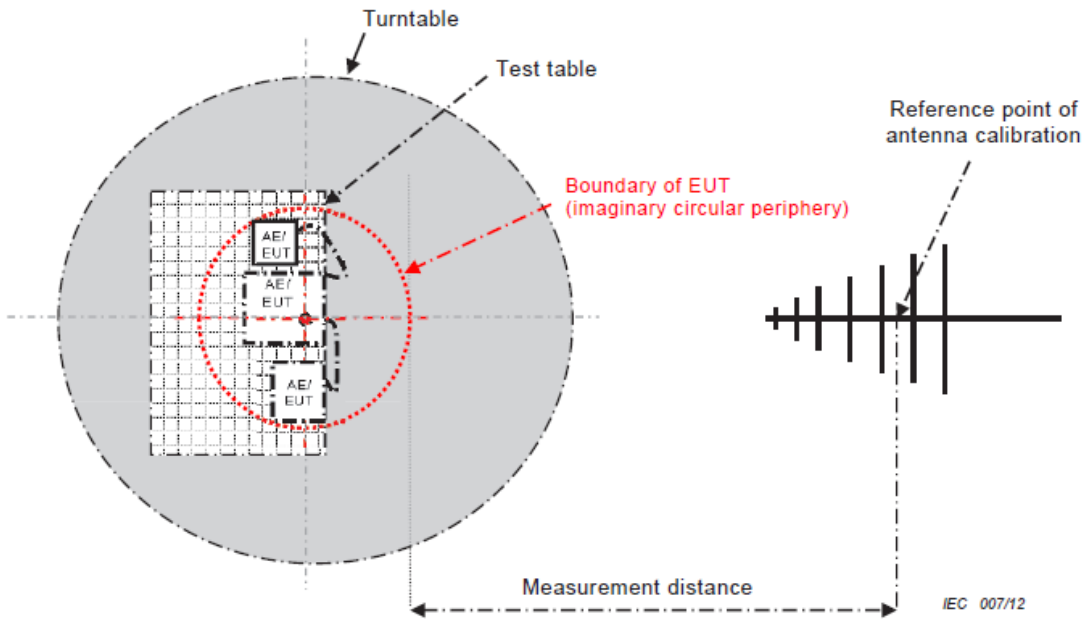

- 34 -

CISPR 32 © IEC:2012

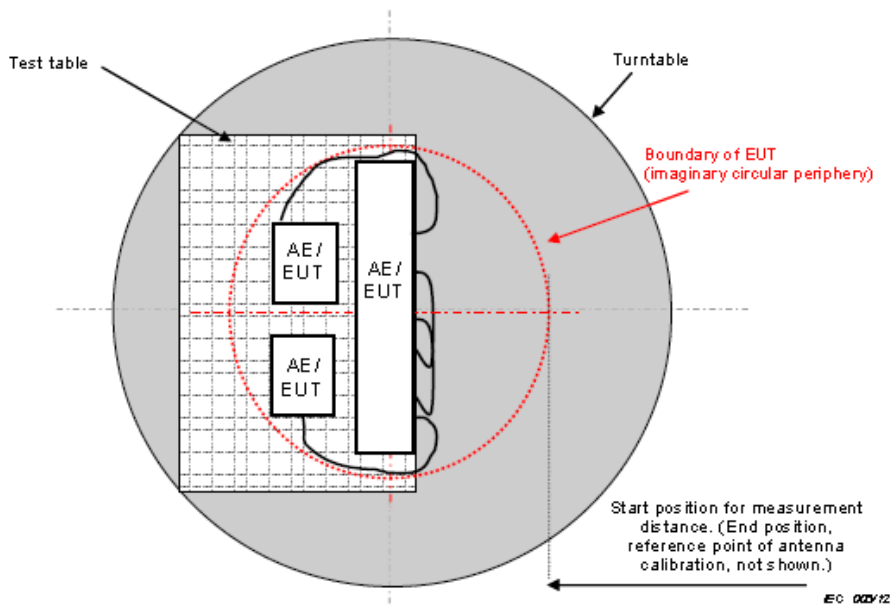
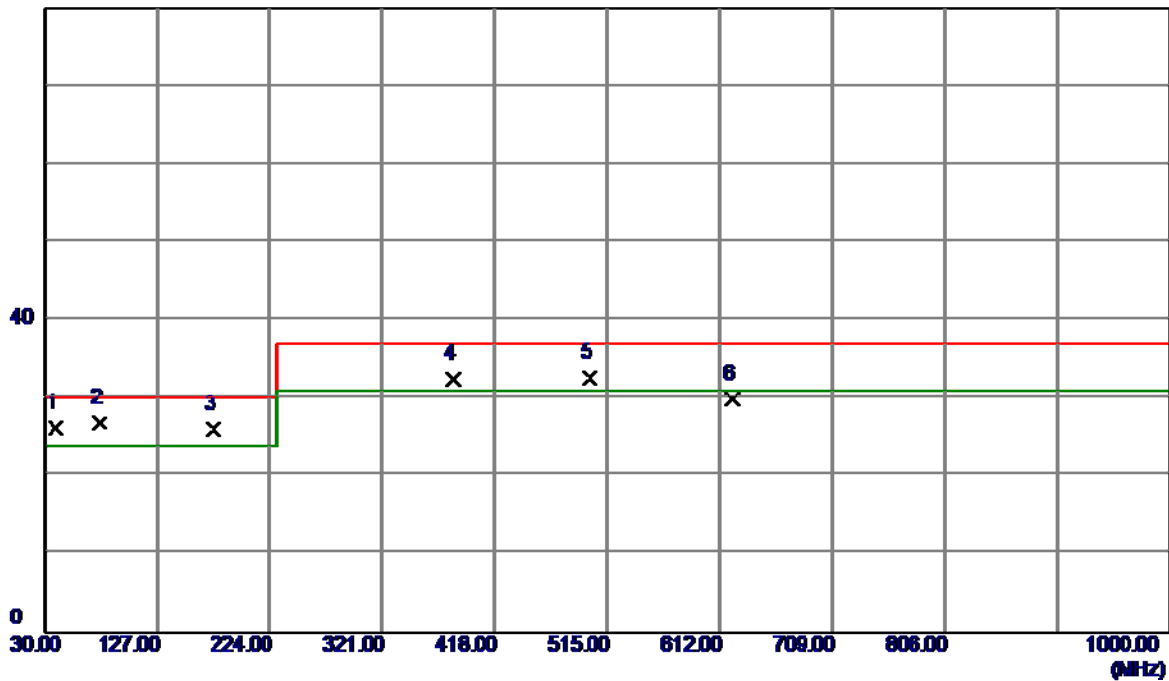

Figure C.2 – Boundary of EUT, Local AE and associated cabling

4.1.7 TEST RESULTS (UP TO 1 GHZ)

EUT	IP Phone	Model Name	H5
Temperature	25°C	Relative Humidity	60%
Test Voltage	AC 230V/50Hz	Polarization	Vertical
Test Mode	Handfree		
Note	Adapter		
Test Engineer	Kevin Li		

80 dBuV/m



No.	Freq. MHz	Reading Level dBuV/m	Correct Factor dB	Measure ment dBuV/m	Limit dBuV/m	Margin dB	Detector
1	39.7000	43.79	-17.49	26.30	30.00	-3.70	QP
2 *	77.0450	46.35	-19.54	26.81	30.00	-3.19	QP
3	175.0150	42.40	-16.25	26.15	30.00	-3.85	QP
4	382.5950	44.48	-12.01	32.47	37.00	-4.53	QP
5	499.9650	41.34	-8.71	32.63	37.00	-4.37	QP
6	623.1550	36.19	-6.26	29.93	37.00	-7.07	QP

EUT	IP Phone	Model Name	H5
Temperature	25°C	Relative Humidity	60%
Test Voltage	AC 230V/50Hz	Polarization	Horizontal
Test Mode	Handfree		
Note	Adapter		
Test Engineer	Kevin Li		

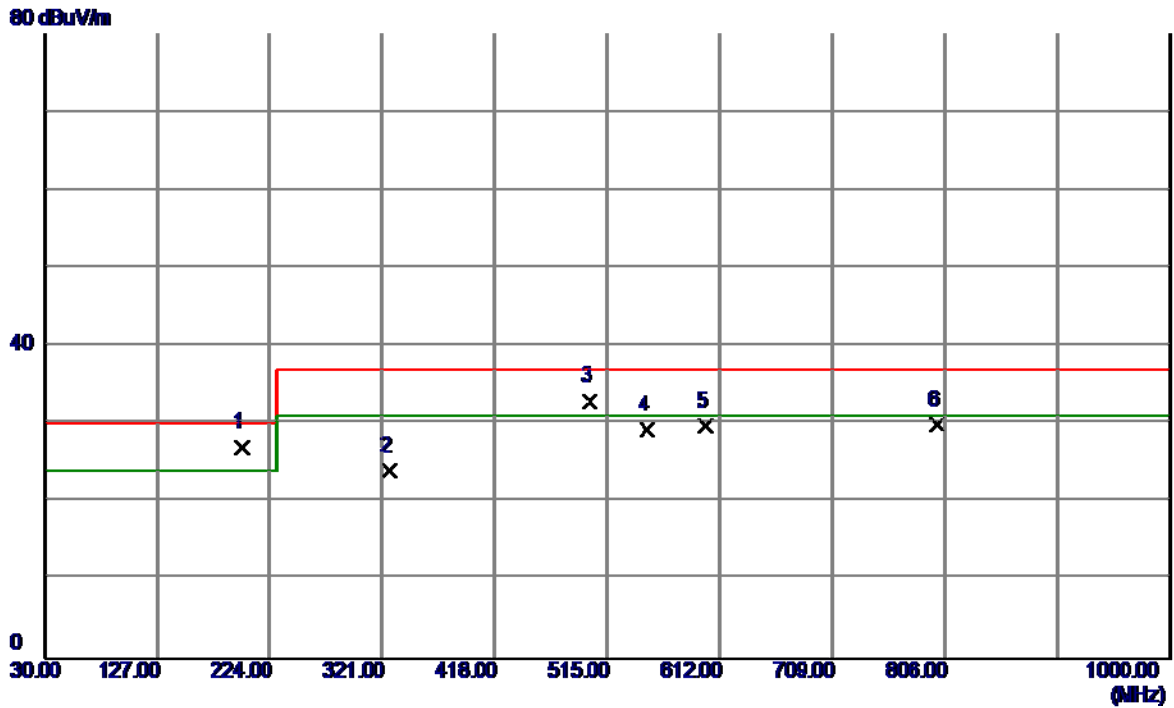

No.	Freq. MHz	Reading Level dBuV/m	Correct Factor dB	Measurement dBuV/m	Limit dBuV/m	Margin dB	Detector
1 *	200.2350	44.84	-17.83	27.01	30.00	-2.99	QP
2	327.7900	37.36	-13.39	23.97	37.00	-13.03	QP
3	499.9650	41.71	-8.71	33.00	37.00	-4.00	QP
4	549.9200	37.28	-8.01	29.27	37.00	-7.73	QP
5	599.8750	36.39	-6.58	29.81	37.00	-7.19	QP
6	799.6950	33.70	-3.71	29.99	37.00	-7.01	QP

EUT	IP Phone	Model Name	H5
Temperature	25°C	Relative Humidity	60%
Test Voltage	PoE 48V	Polarization	Vertical
Test Mode	Handfree		
Note	POE		
Test Engineer	Kevin Li		

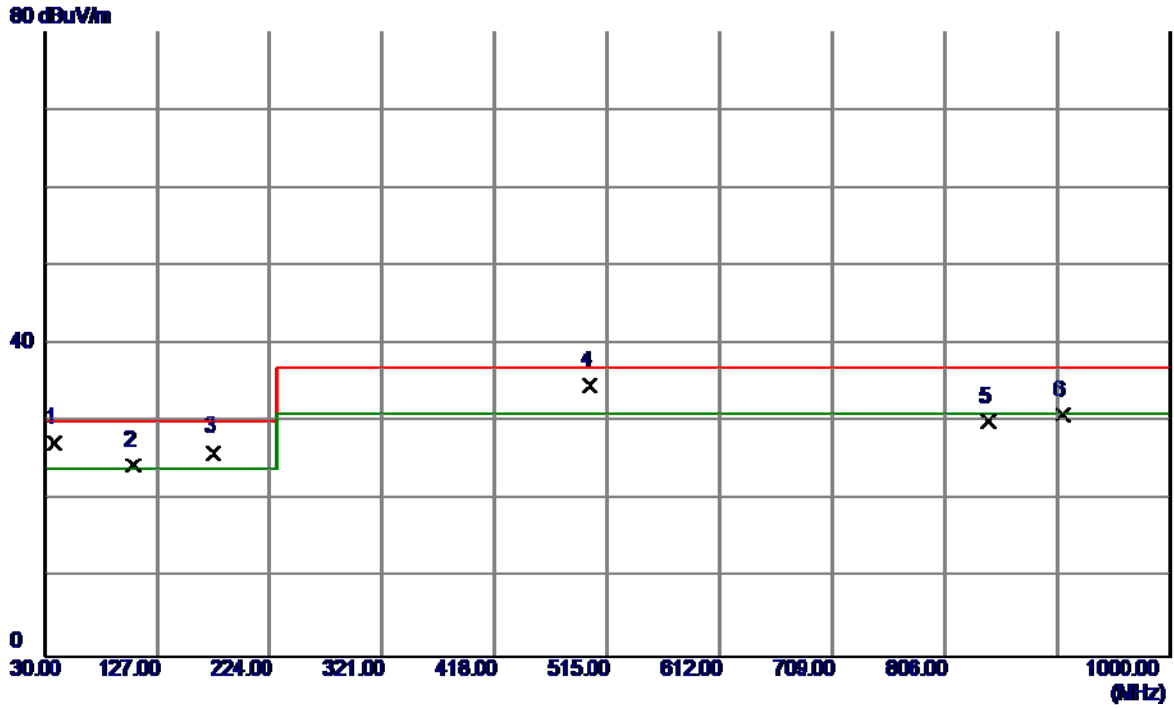

No.	Freq. MHz	Reading Level dBuV/m	Correct Factor dB	Measure ment dBuV/m	Limit dBuV/m	Margin dB	Detector
1	38.7300	44.97	-17.59	27.38	30.00	-2.62	QP
2	106.6300	43.67	-19.25	24.42	30.00	-5.58	QP
3	175.0150	42.41	-16.25	26.16	30.00	-3.84	QP
4 *	499.9650	43.40	-8.71	34.69	37.00	-2.31	QP
5	843.8300	33.10	-3.08	30.02	37.00	-6.98	QP
6	906.8800	32.86	-2.04	30.82	37.00	-6.18	QP

EUT	IP Phone	Model Name	H5
Temperature	25°C	Relative Humidity	60%
Test Voltage	PoE 48V	Polarization	Horizontal
Test Mode	Handfree		
Note	POE		
Test Engineer	Kevin Li		

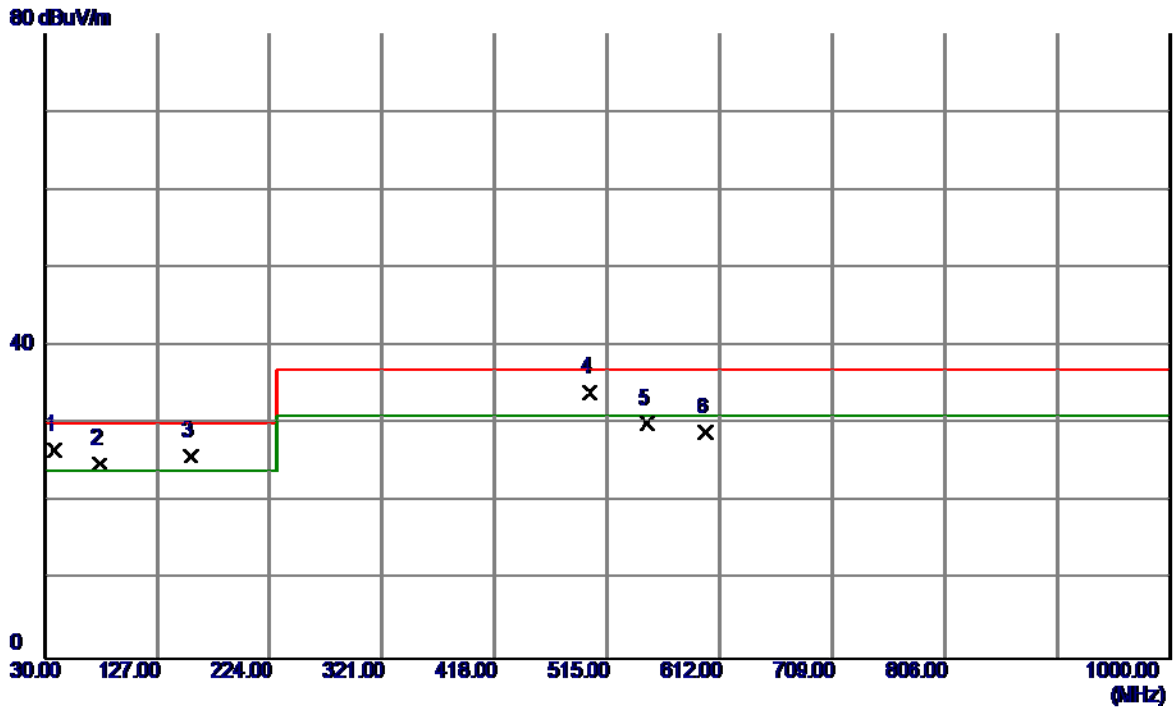

No.	Freq. MHz	Reading Level dBuV/m	Correct Factor dB	Measure ment dBuV/m	Limit dBuV/m	Margin dB	Detector
1	38.7300	44.34	-17.59	26.75	30.00	-3.25	QP
2	77.0450	44.49	-19.54	24.95	30.00	-5.05	QP
3	155.6150	41.24	-15.29	25.95	30.00	-4.05	QP
4 *	499.9650	42.75	-8.71	34.04	37.00	-2.96	QP
5	549.9200	38.13	-8.01	30.12	37.00	-6.88	QP
6	599.8750	35.57	-6.58	28.99	37.00	-8.01	QP

EUT	IP Phone	Model Name	H5
Temperature	25°C	Relative Humidity	60%
Test Voltage	AC 230V/50Hz	Polarization	Vertical
Test Mode	Handset		
Note	Adapter		
Test Engineer	Kevin Li		

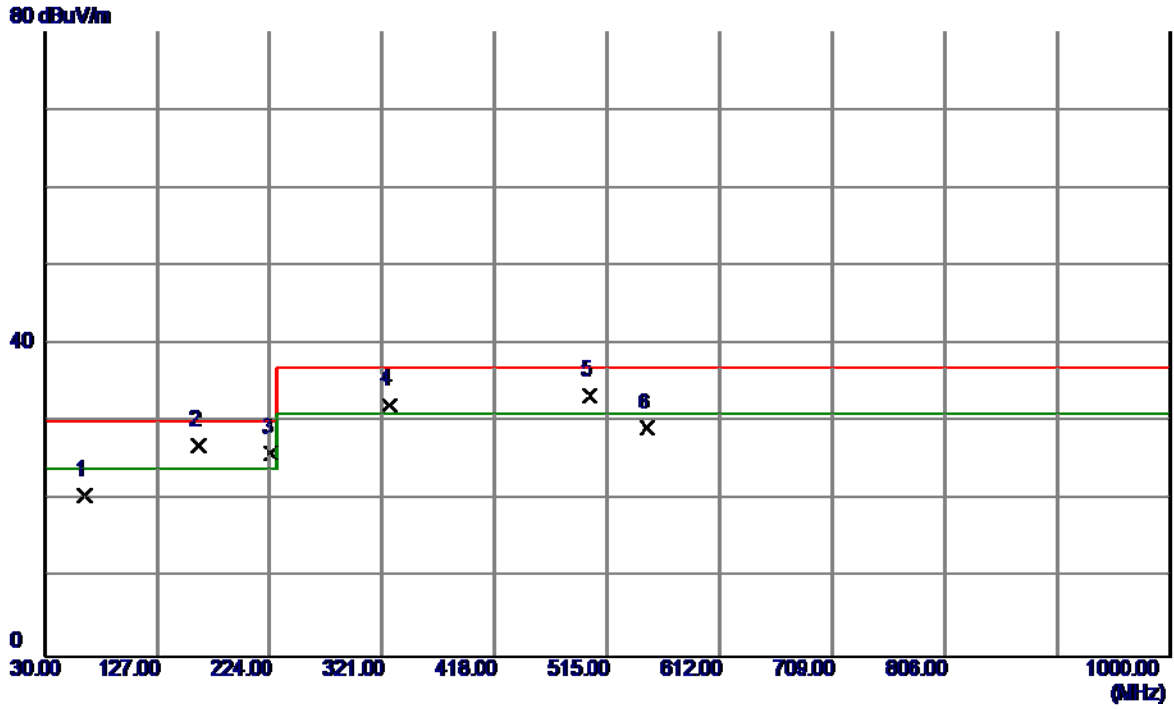

No.	Freq. MHz	Reading Level dBuV/m	Correct Factor dB	Measure ment dBuV/m	Limit dBuV/m	Margin dB	Detector
1	64.9200	38.14	-17.44	20.70	30.00	-9.30	QP
2 *	162.4050	42.32	-15.34	26.98	30.00	-3.02	QP
3	224.9700	43.88	-17.81	26.07	30.00	-3.93	QP
4	327.7900	45.63	-13.39	32.24	37.00	-4.76	QP
5	499.9650	42.20	-8.71	33.49	37.00	-3.51	QP
6	549.9200	37.25	-8.01	29.24	37.00	-7.76	QP

EUT	IP Phone	Model Name	H5
Temperature	25°C	Relative Humidity	60%
Test Voltage	AC 230V/50Hz	Polarization	Horizontal
Test Mode	Handset		
Note	Adapter		
Test Engineer	Kevin Li		

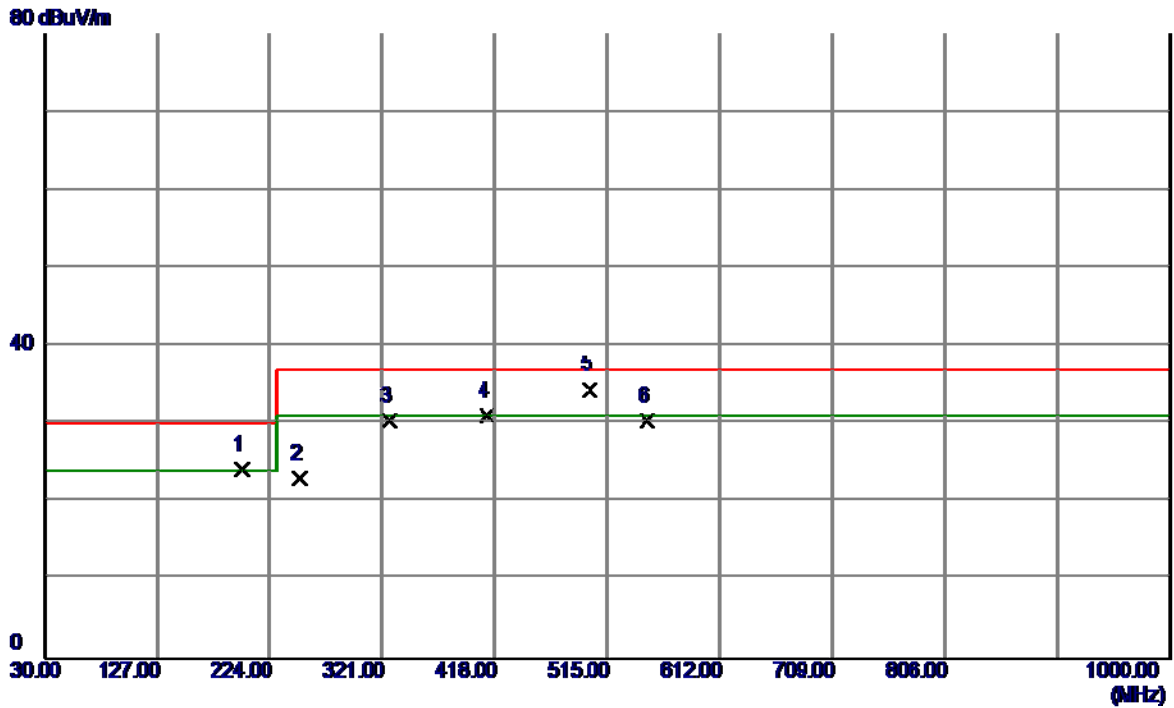

No.	Freq. MHz	Reading Level dBuV/m	Correct Factor dB	Measure ment dBuV/m	Limit dBuV/m	Margin dB	Detector
1	200.2350	41.98	-17.83	24.15	30.00	-5.85	QP
2	250.1900	38.99	-15.95	23.04	37.00	-13.96	QP
3	327.3050	43.86	-13.40	30.46	37.00	-6.54	QP
4	411.2100	42.21	-11.11	31.10	37.00	-5.90	QP
5 *	499.9650	43.12	-8.71	34.41	37.00	-2.59	QP
6	549.9200	38.45	-8.01	30.44	37.00	-6.56	QP

EUT	IP Phone	Model Name	H5
Temperature	25°C	Relative Humidity	60%
Test Voltage	PoE 48V	Polarization	Vertical
Test Mode	Handset		
Note	POE		
Test Engineer	Kevin Li		

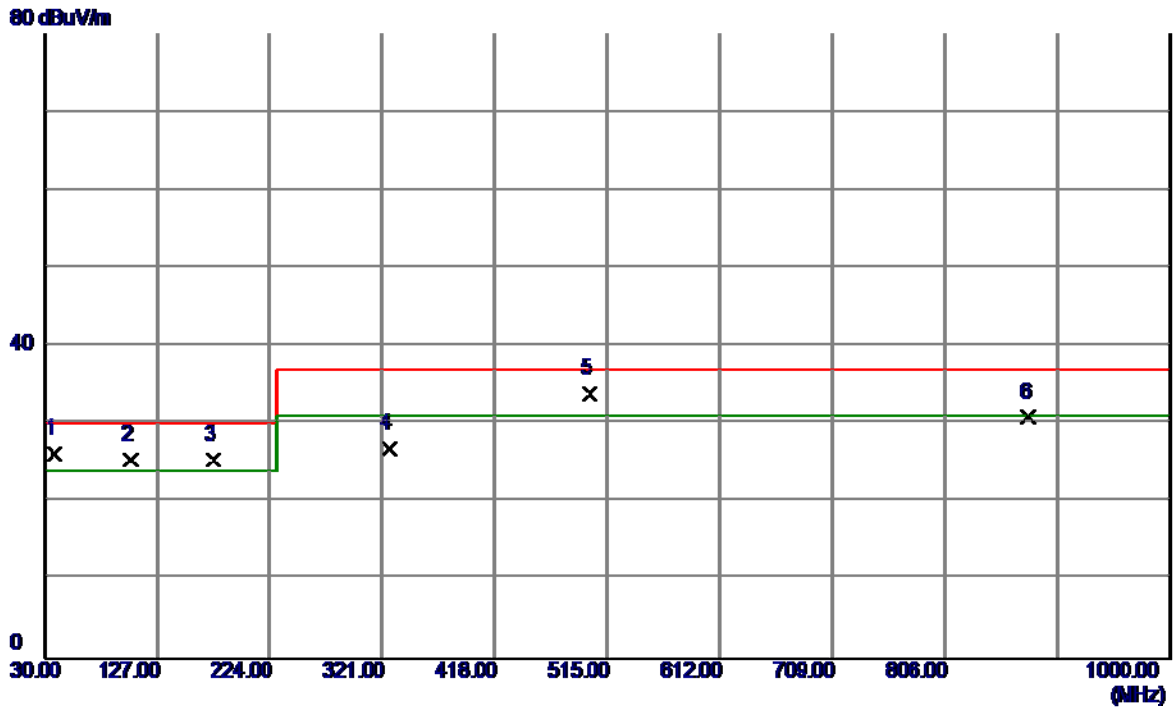

No.	Freq. MHz	Reading Level dBuV/m	Correct Factor dB	Measure ment dBuV/m	Limit dBuV/m	Margin dB	Detector
1	38.7300	43.76	-17.59	26.17	30.00	-3.83	QP
2	104.6900	44.94	-19.57	25.37	30.00	-4.63	QP
3	175.0150	41.70	-16.25	25.45	30.00	-4.55	QP
4	327.3050	40.29	-13.40	26.89	37.00	-10.11	QP
5 *	499.9650	42.67	-8.71	33.96	37.00	-3.04	QP
6	878.7500	33.44	-2.51	30.93	37.00	-6.07	QP

EUT	IP Phone	Model Name	H5
Temperature	25°C	Relative Humidity	60%
Test Voltage	PoE 48V	Polarization	Horizontal
Test Mode	Handset		
Note	POE		
Test Engineer	Kevin Li		

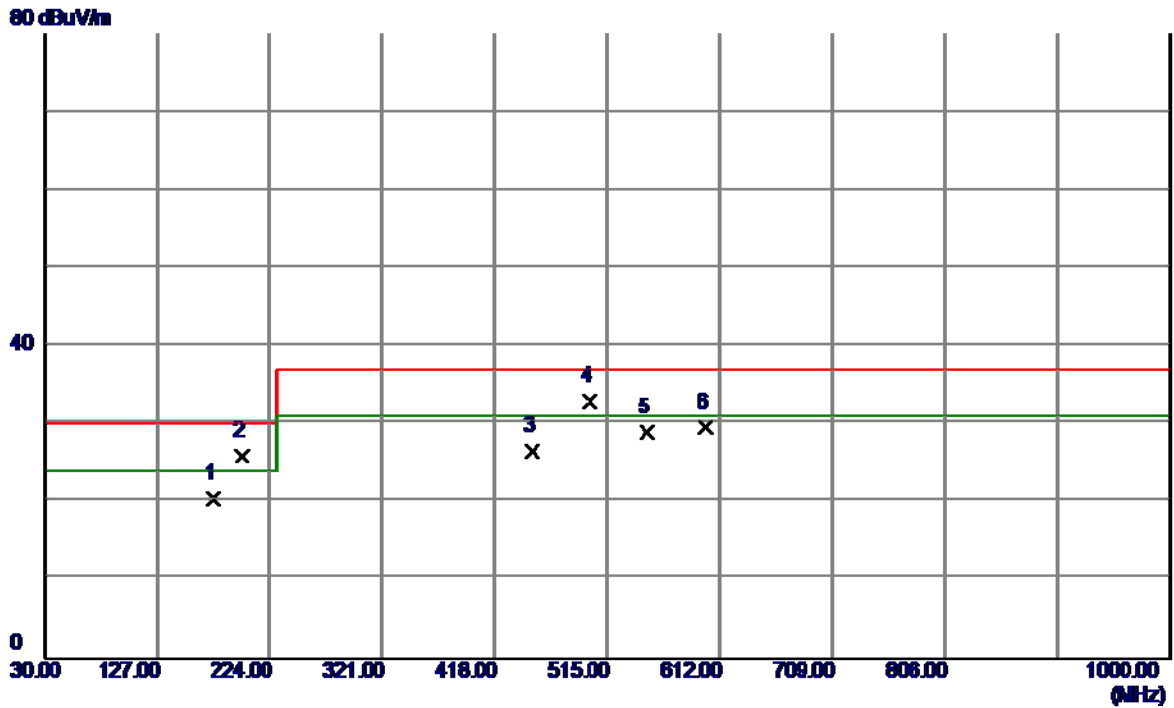

No.	Freq. MHz	Reading Level dBuV/m	Correct Factor dB	Measure ment dBuV/m	Limit dBuV/m	Margin dB	Detector
1	175.0150	36.79	-16.25	20.54	30.00	-9.46	QP
2	200.2350	43.74	-17.83	25.91	30.00	-4.09	QP
3	450.0100	36.29	-9.66	26.63	37.00	-10.37	QP
4 *	499.9650	41.70	-8.71	32.99	37.00	-4.01	QP
5	549.9200	36.92	-8.01	28.91	37.00	-8.09	QP
6	599.8750	36.18	-6.58	29.60	37.00	-7.40	QP

4.1.8 TEST RESULTS (ABOVE 1 GHZ)

EUT	IP Phone	Model Name	H5
Temperature	25°C	Relative Humidity	45%
Test Voltage	AC 230V/50Hz	Polarization	Vertical
Test Mode	Handfree		
Note	Adapter		
Test Engineer	Kevin Li		

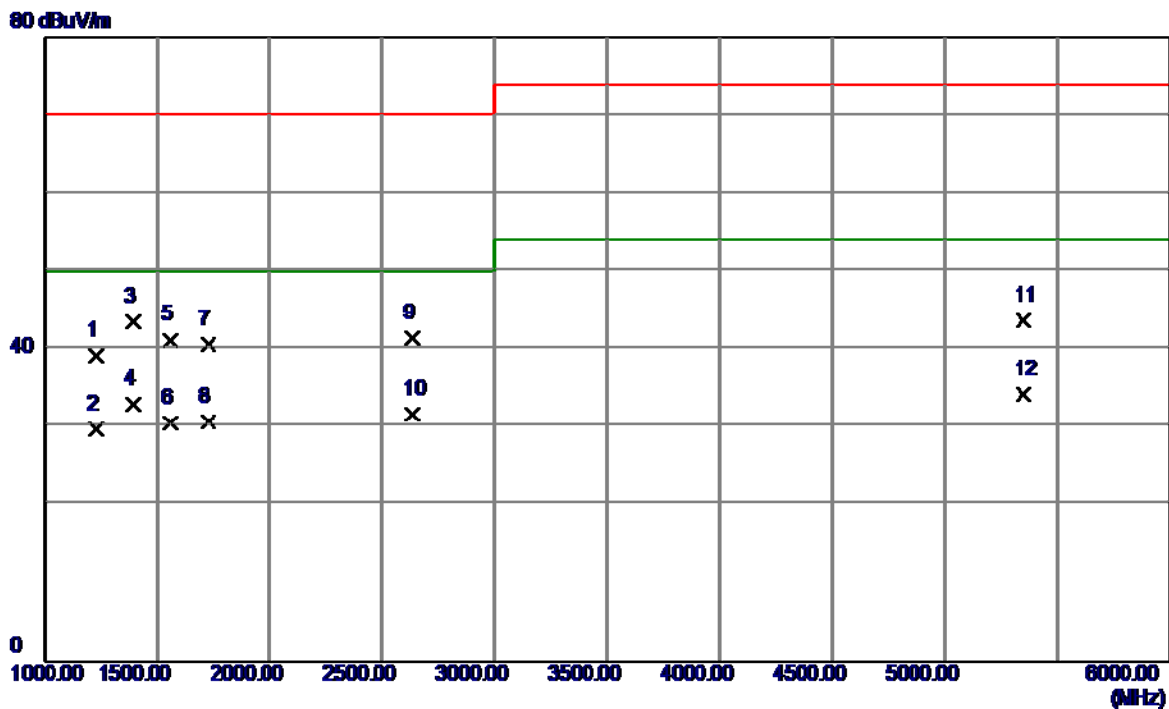

No.	Freq. MHz	Reading Level dBuV/m	Correct Factor dB	Measure ment dBuV/m	Limit dBuV/m	Margin dB	Detector
1	1230.0000	42.19	-3.02	39.17	70.00	-30.83	Peak
2	1230.0000	32.73	-3.02	29.71	50.00	-20.29	AVG
3	1392.5000	46.33	-2.86	43.47	70.00	-26.53	Peak
4 *	1392.5000	35.77	-2.86	32.91	50.00	-17.09	AVG
5	1560.0000	44.12	-2.92	41.20	70.00	-28.80	Peak
6	1560.0000	33.42	-2.92	30.50	50.00	-19.50	AVG
7	1725.0000	44.03	-3.35	40.68	70.00	-29.32	Peak
8	1725.0000	34.09	-3.35	30.74	50.00	-19.26	AVG
9	2632.5000	41.25	0.13	41.38	70.00	-28.62	Peak
10	2632.5000	31.58	0.13	31.71	50.00	-18.29	AVG
11	5350.0000	36.12	7.58	43.70	74.00	-30.30	Peak
12	5350.0000	26.66	7.58	34.24	54.00	-19.76	AVG

EUT	IP Phone	Model Name	H5
Temperature	25°C	Relative Humidity	45%
Test Voltage	AC 230V/50Hz	Polarization	Horizontal
Test Mode	Handfree		
Note	Adapter		
Test Engineer	Kevin Li		

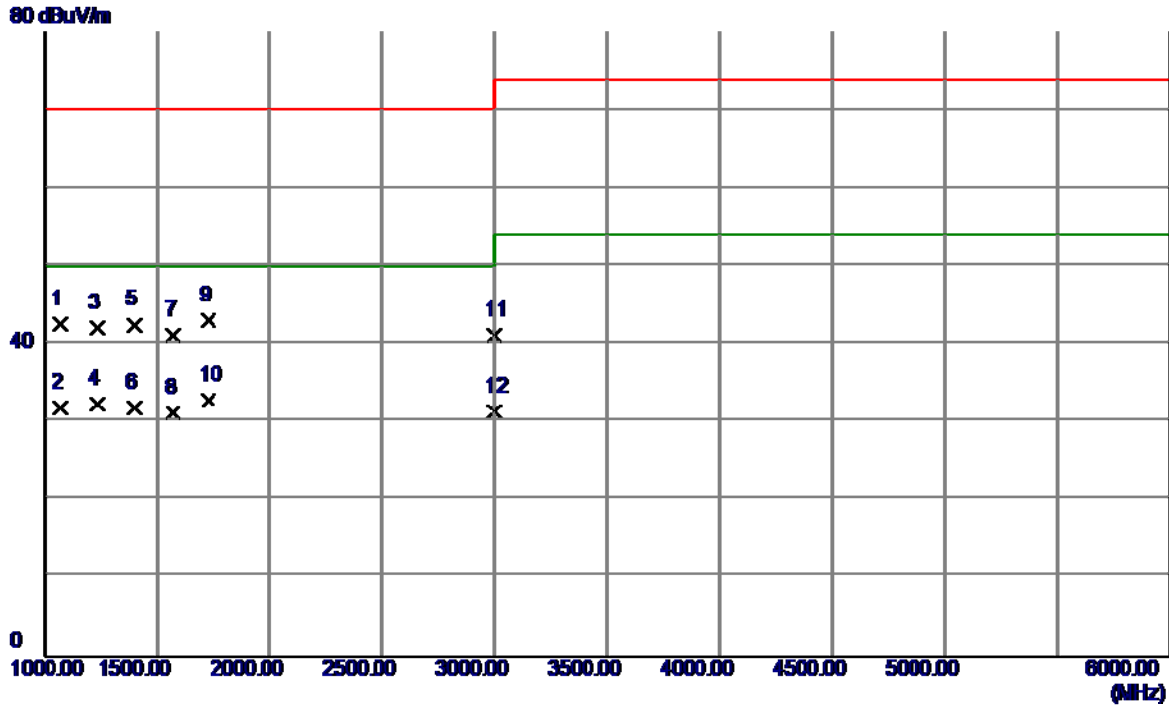

No.	Freq. MHz	Reading Level dBuV/m	Correct Factor dB	Measure ment dBuV/m	Limit dBuV/m	Margin dB	Detector
1	1070.0000	45.67	-3.17	42.50	70.00	-27.50	Peak
2	1070.0000	34.95	-3.17	31.78	50.00	-18.22	AVG
3	1235.0000	45.13	-3.01	42.12	70.00	-27.88	Peak
4	1235.0000	35.38	-3.01	32.37	50.00	-17.63	AVG
5	1397.5000	45.34	-2.86	42.48	70.00	-27.52	Peak
6	1397.5000	34.76	-2.86	31.90	50.00	-18.10	AVG
7	1575.0000	44.02	-2.96	41.06	70.00	-28.94	Peak
8	1575.0000	34.21	-2.96	31.25	50.00	-18.75	AVG
9	1727.5000	46.42	-3.35	43.07	70.00	-26.93	Peak
10 *	1727.5000	36.22	-3.35	32.87	50.00	-17.13	AVG
11	3000.0000	39.22	1.97	41.19	70.00	-28.81	Peak
12	3000.0000	29.38	1.97	31.35	50.00	-18.65	AVG

EUT	IP Phone	Model Name	H5
Temperature	25°C	Relative Humidity	45%
Test Voltage	PoE 48V	Polarization	Vertical
Test Mode	Handfree		
Note	POE		
Test Engineer	Kevin Li		

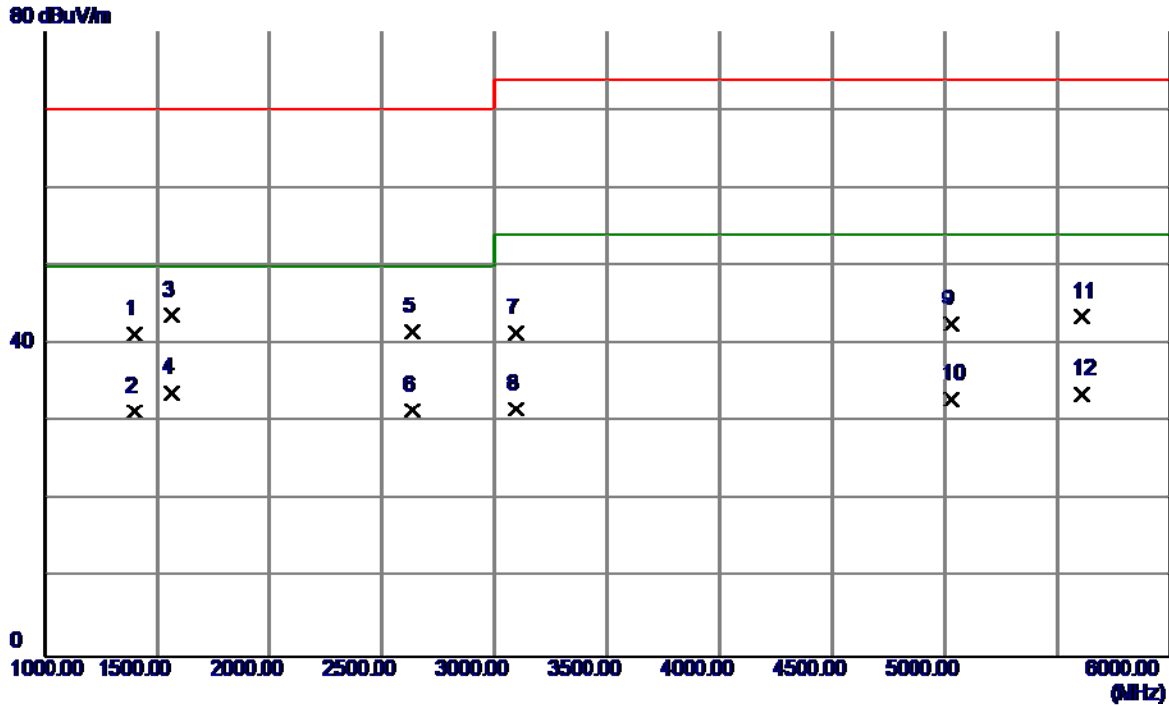

No.	Freq. MHz	Reading Level dBuV/m	Correct Factor dB	Measure ment dBuV/m	Limit dBuV/m	Margin dB	Detector
1	1397.5000	44.07	-2.86	41.21	70.00	-28.79	Peak
2	1397.5000	34.24	-2.86	31.38	50.00	-18.62	AVG
3	1565.0000	46.69	-2.93	43.76	70.00	-26.24	Peak
4 *	1565.0000	36.71	-2.93	33.78	50.00	-16.22	AVG
5	2635.0000	41.40	0.14	41.54	70.00	-28.46	Peak
6	2635.0000	31.42	0.14	31.56	50.00	-18.44	AVG
7	3095.0000	39.43	2.06	41.49	74.00	-32.51	Peak
8	3095.0000	29.62	2.06	31.68	54.00	-22.32	AVG
9	5027.5000	36.07	6.48	42.55	74.00	-31.45	Peak
10	5027.5000	26.41	6.48	32.89	54.00	-21.11	AVG
11	5612.5000	35.34	8.19	43.53	74.00	-30.47	Peak
12	5612.5000	25.41	8.19	33.60	54.00	-20.40	AVG

EUT	IP Phone	Model Name	H5
Temperature	25°C	Relative Humidity	45%
Test Voltage	PoE 48V	Polarization	Horizontal
Test Mode	Handfree		
Note	POE		
Test Engineer	Kevin Li		

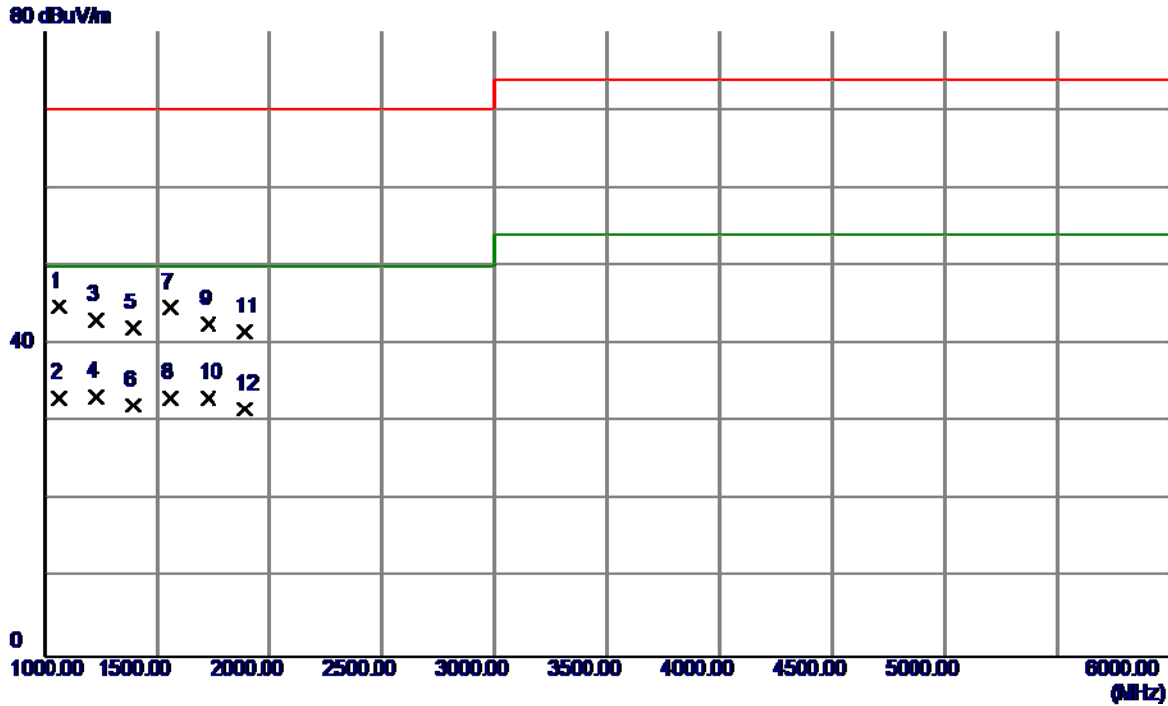

No.	Freq. MHz	Reading Level dBuV/m	Correct Factor dB	Measure ment dBuV/m	Limit dBuV/m	Margin dB	Detector
1	1067.5000	47.92	-3.18	44.74	70.00	-25.26	Peak
2	1067.5000	36.35	-3.18	33.17	50.00	-16.83	AVG
3	1230.0000	46.14	-3.02	43.12	70.00	-26.88	Peak
4 *	1230.0000	36.32	-3.02	33.30	50.00	-16.70	AVG
5	1392.5000	44.92	-2.86	42.06	70.00	-27.94	Peak
6	1392.5000	35.01	-2.86	32.15	50.00	-17.85	AVG
7	1562.5000	47.62	-2.92	44.70	70.00	-25.30	Peak
8	1562.5000	36.11	-2.92	33.19	50.00	-16.81	AVG
9	1727.5000	45.92	-3.35	42.57	70.00	-27.43	Peak
10	1727.5000	36.40	-3.35	33.05	50.00	-16.95	AVG
11	1887.5000	45.38	-3.77	41.61	70.00	-28.39	Peak
12	1887.5000	35.41	-3.77	31.64	50.00	-18.36	AVG

EUT	IP Phone	Model Name	H5
Temperature	25°C	Relative Humidity	45%
Test Voltage	AC 230V/50Hz	Polarization	Vertical
Test Mode	Handset		
Note	Adapter		
Test Engineer	Kevin Li		

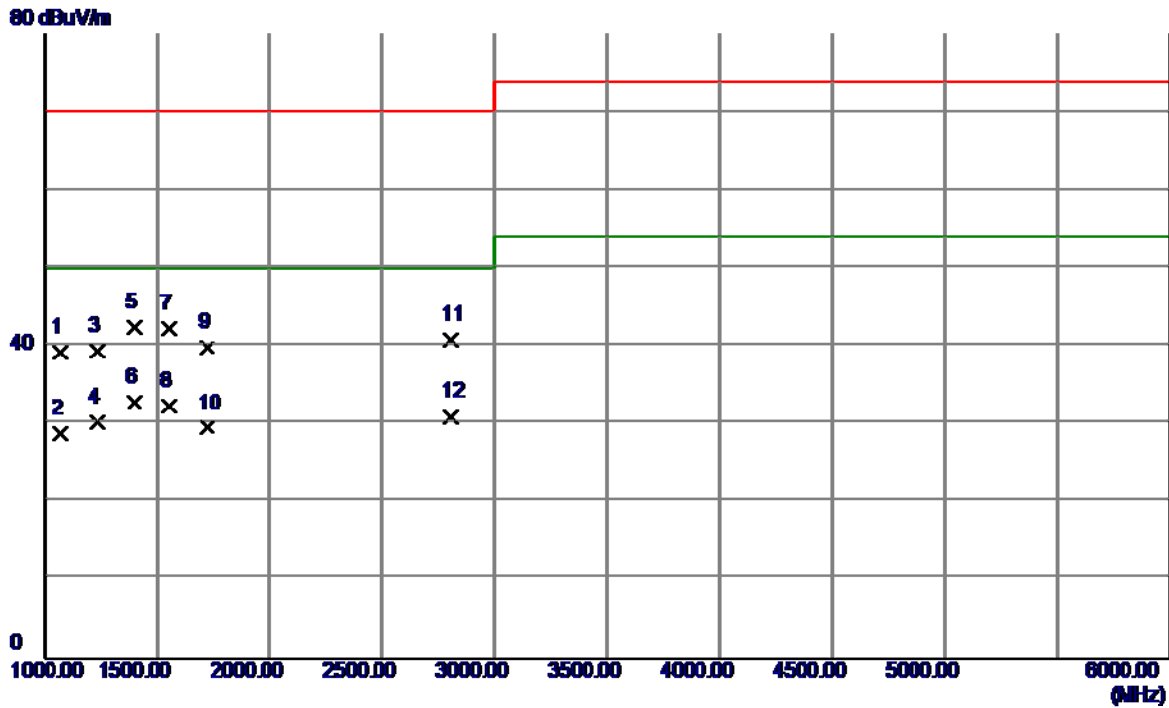

No.	Freq. MHz	Reading Level dBuV/m	Correct Factor dB	Measure ment dBuV/m	Limit dBuV/m	Margin dB	Detector
1	1072.5000	42.44	-3.17	39.27	70.00	-30.73	Peak
2	1072.5000	31.97	-3.17	28.80	50.00	-21.20	AVG
3	1235.0000	42.42	-3.01	39.41	70.00	-30.59	Peak
4	1235.0000	33.32	-3.01	30.31	50.00	-19.69	AVG
5	1397.5000	45.21	-2.86	42.35	70.00	-27.65	Peak
6 *	1397.5000	35.69	-2.86	32.83	50.00	-17.17	AVG
7	1557.5000	45.08	-2.91	42.17	70.00	-27.83	Peak
8	1557.5000	35.18	-2.91	32.27	50.00	-17.73	AVG
9	1720.0000	43.25	-3.33	39.92	70.00	-30.08	Peak
10	1720.0000	32.85	-3.33	29.52	50.00	-20.48	AVG
11	2805.0000	39.85	0.99	40.84	70.00	-29.16	Peak
12	2805.0000	29.97	0.99	30.96	50.00	-19.04	AVG

EUT	IP Phone	Model Name	H5
Temperature	25°C	Relative Humidity	45%
Test Voltage	AC 230V/50Hz	Polarization	Horizontal
Test Mode	Handset		
Note	Adapter		
Test Engineer	Kevin Li		

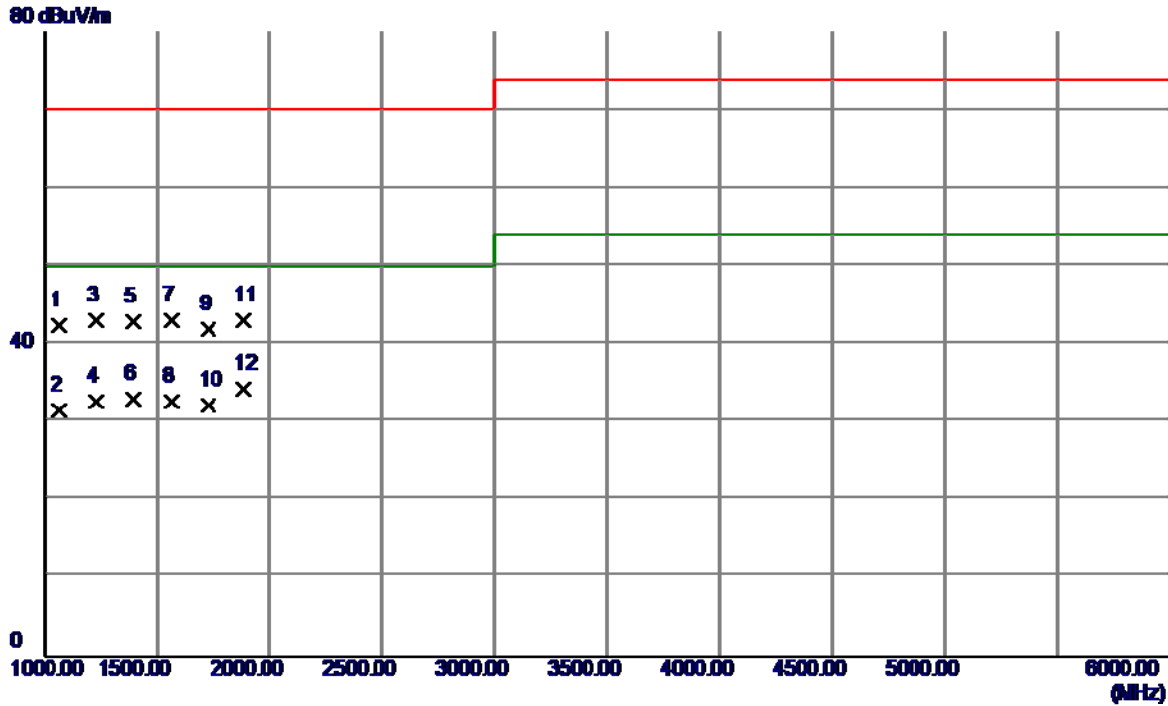

No.	Freq. MHz	Reading Level dBuV/m	Correct Factor dB	Measure ment dBuV/m	Limit dBuV/m	Margin dB	Detector
1	1065.0000	45.64	-3.18	42.46	70.00	-27.54	Peak
2	1065.0000	34.63	-3.18	31.45	50.00	-18.55	AVG
3	1227.5000	46.07	-3.02	43.05	70.00	-26.95	Peak
4	1227.5000	35.70	-3.02	32.68	50.00	-17.32	AVG
5	1395.0000	45.71	-2.86	42.85	70.00	-27.15	Peak
6	1395.0000	35.80	-2.86	32.94	50.00	-17.06	AVG
7	1565.0000	46.03	-2.93	43.10	70.00	-26.90	Peak
8	1565.0000	35.50	-2.93	32.57	50.00	-17.43	AVG
9	1730.0000	45.34	-3.36	41.98	70.00	-28.02	Peak
10	1730.0000	35.45	-3.36	32.09	50.00	-17.91	AVG
11	1885.0000	46.73	-3.76	42.97	70.00	-27.03	Peak
12 *	1885.0000	38.04	-3.76	34.28	50.00	-15.72	AVG

EUT	IP Phone	Model Name	H5
Temperature	25°C	Relative Humidity	45%
Test Voltage	PoE 48V	Polarization	Vertical
Test Mode	Handset		
Note	POE		
Test Engineer	Kevin Li		

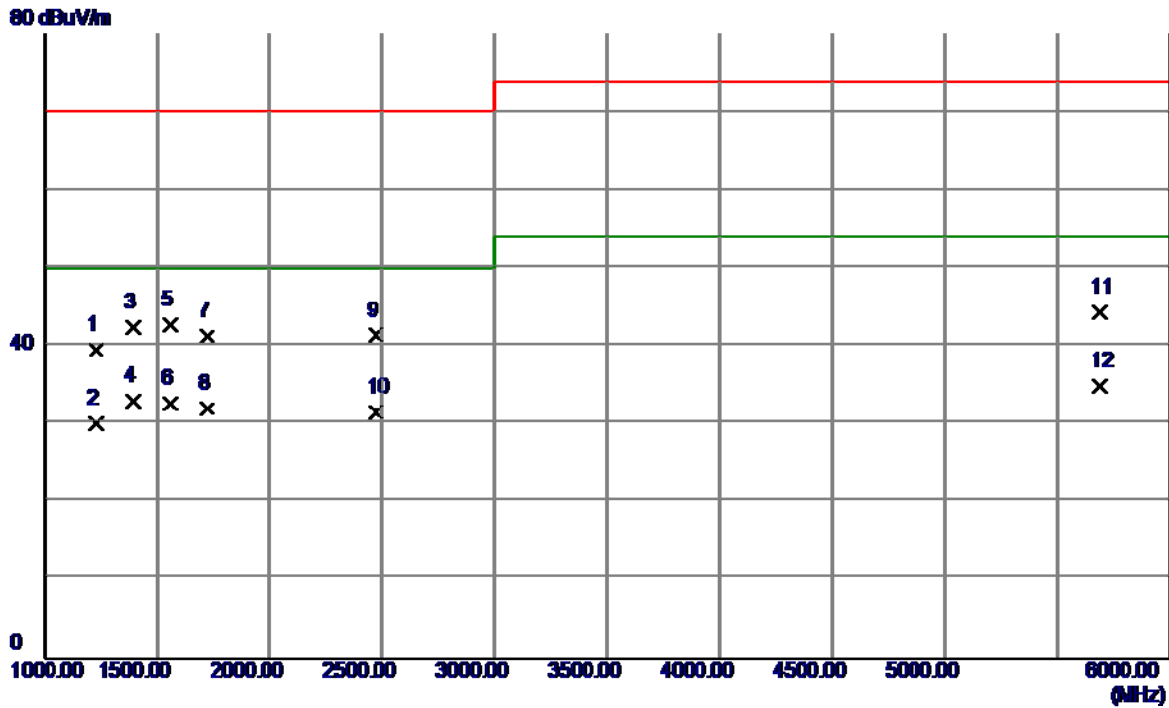

No.	Freq. MHz	Reading Level dBuV/m	Correct Factor dB	Measure ment dBuV/m	Limit dBuV/m	Margin dB	Detector
1	1230.0000	42.57	-3.02	39.55	70.00	-30.45	Peak
2	1230.0000	33.05	-3.02	30.03	50.00	-19.97	AVG
3	1392.5000	45.23	-2.86	42.37	70.00	-27.63	Peak
4 *	1392.5000	35.78	-2.86	32.92	50.00	-17.08	AVG
5	1562.5000	45.59	-2.92	42.67	70.00	-27.33	Peak
6	1562.5000	35.53	-2.92	32.61	50.00	-17.39	AVG
7	1722.5000	44.59	-3.34	41.25	70.00	-28.75	Peak
8	1722.5000	35.39	-3.34	32.05	50.00	-17.95	AVG
9	2470.0000	42.11	-0.75	41.36	70.00	-28.64	Peak
10	2470.0000	32.22	-0.75	31.47	50.00	-18.53	AVG
11	5687.5000	36.03	8.25	44.28	74.00	-29.72	Peak
12	5687.5000	26.67	8.25	34.92	54.00	-19.08	AVG

EUT	IP Phone	Model Name	H5
Temperature	25°C	Relative Humidity	45%
Test Voltage	PoE 48V	Polarization	Horizontal
Test Mode	Handset		
Note	POE		
Test Engineer	Kevin Li		

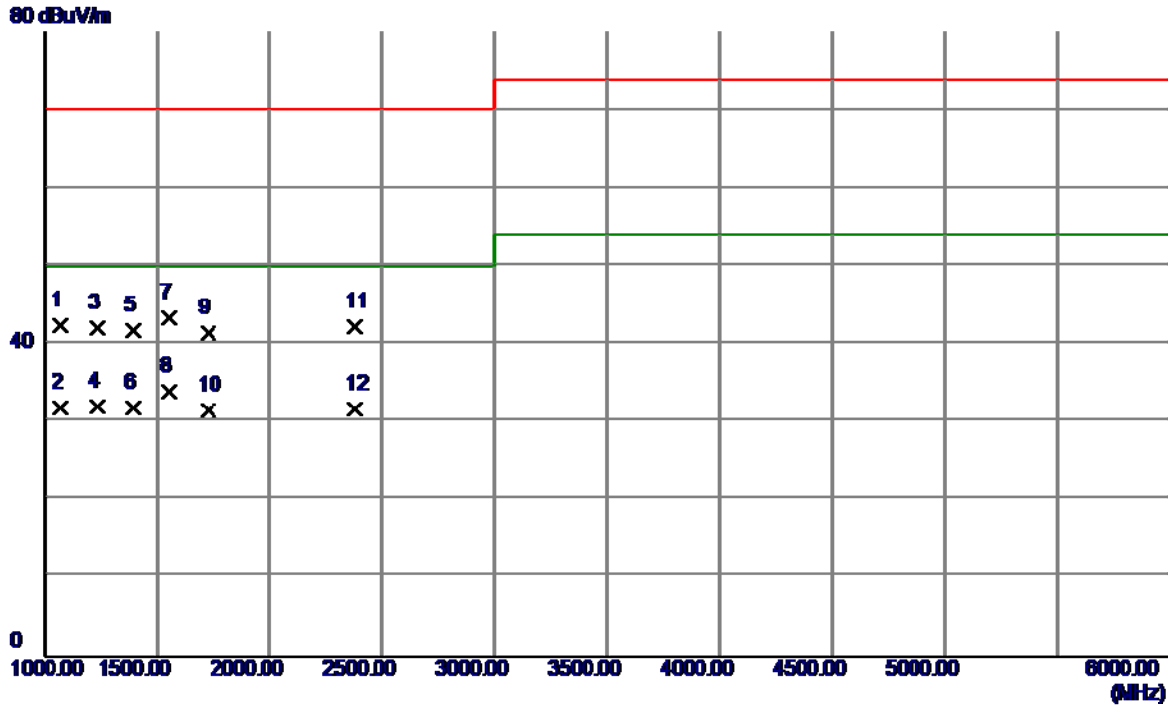

No.	Freq. MHz	Reading Level dBuV/m	Correct Factor dB	Measure ment dBuV/m	Limit dBuV/m	Margin dB	Detector
1	1070.0000	45.59	-3.17	42.42	70.00	-27.58	Peak
2	1070.0000	34.95	-3.17	31.78	50.00	-18.22	AVG
3	1232.5000	45.11	-3.02	42.09	70.00	-27.91	Peak
4	1232.5000	35.05	-3.02	32.03	50.00	-17.97	AVG
5	1392.5000	44.66	-2.86	41.80	70.00	-28.20	Peak
6	1392.5000	34.74	-2.86	31.88	50.00	-18.12	AVG
7	1555.0000	46.31	-2.90	43.41	70.00	-26.59	Peak
8 *	1555.0000	36.80	-2.90	33.90	50.00	-16.10	AVG
9	1725.0000	44.75	-3.35	41.40	70.00	-28.60	Peak
10	1725.0000	34.93	-3.35	31.58	50.00	-18.42	AVG
11	2377.5000	43.67	-1.40	42.27	70.00	-27.73	Peak
12	2377.5000	33.08	-1.40	31.68	50.00	-18.32	AVG

4.2 CONDUCTED EMISSION MEASUREMENT AT AC MAINS POWER PORTS

4.2.1 LIMITS

Requirements for conducted emissions from AC mains power ports of Class A equipment

Table clause	Frequency Range MHz	Coupling Device	Detector Type / bandwidth	Class A Limits (dB(μV))
A8.1	0.15 - 0.5	AMN	Quasi Peak / 9 kHz	79
	0.5 - 30			73
A8.2	0.15 - 0.5	AMN	Average / 9 kHz	66
	0.5 - 30			60

Requirements for conducted emissions from AC mains power ports of Class B equipment

Table clause	Frequency Range MHz	Coupling Device	Detector Type / bandwidth	Class B Limits (dB(μV))
A9.1	0.15 - 0.5	AMN	Quasi Peak / 9 kHz	66-56
	0.5 - 5			56
	5 - 30			60
A9.2	0.15 - 0.5	AMN	Average / 9 kHz	56-46
	0 5 - 5			46
	5 - 30			50

NOTE:

- (1) The test result calculated as following:
 Measurement Value = Reading Level + Correct Factor
 Correct Factor = Insertion Loss + Cable Loss + Attenuator Factor(if use)
 Margin Level = Measurement Value – Limit Value

4.2.2 MEASUREMENT INSTRUMENTS LIST

Item	Kind of Equipment	Manufacturer	Type No.	Serial No.	Calibrated until
1	Measurement Software	Farad	EZ-EMC Ver.NB-03A 1-01	N/A	N/A
2	50Ω Terminator	SHX	TF2-3G-A	08122901	Mar. 27, 2017
3	TWO-LINE V-NETWORK	R&S	ENV216	100526	Mar. 27, 2017
4	EMI Test Receiver	R&S	ESR3	101862	Sep. 04, 2017
5	Artificial-Mains Network	SCHWARZBECK	NSLK 8127	8127685	Sep. 04, 2017
6	Cable	N/A	RG400 12m	N/A	Mar. 10, 2017

Remark: "N/A" denotes no model name, no serial no. or no calibration specified.
 All calibration period of equipment list is one year.

4.2.3 TEST PROCEDURE

- a. The EUT was placed 0.8 meters from the horizontal ground plane with EUT being connected to the power mains through a line impedance stabilization network (LISN). All other support equipments powered from additional LISN(s). The LISN provide 50 Ohm/ 50uH of coupling impedance for the measuring instrument.
- b. Interconnecting cables that hang closer than 40 cm to the ground plane shall be folded back and forth in the center forming a bundle 30 to 40 cm long.
- c. I/O cables that are not connected to a peripheral shall be bundled in the center. The end of the cable may be terminated, if required, using the correct terminating impedance. The overall length shall not exceed 1 m.
- d. LISN at least 80 cm from nearest part of EUT chassis.
- e. For the actual test configuration, please refer to the related Item –EUT Test Photos.

4.2.4 DEVIATION FROM TEST STANDARD

No deviation

4.2.5 TEST SETUP

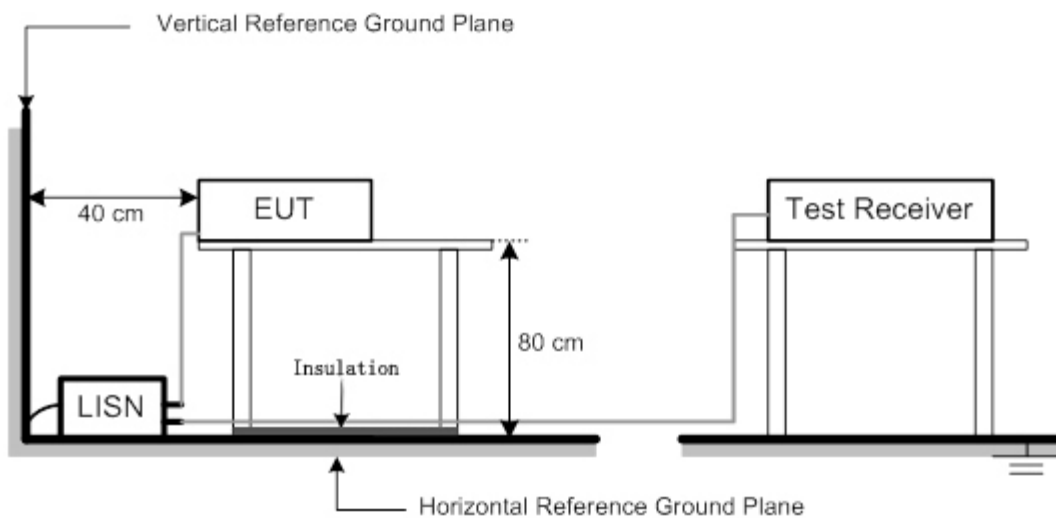

4.2.6 TEST RESULTS

EUT	IP Phone	Model Name	H5
Temperature	25°C	Relative Humidity	53%
Test Voltage	AC 230V/50Hz	Phase	Line
Test Mode	Handfree		
Test Engineer	Kevin Li		

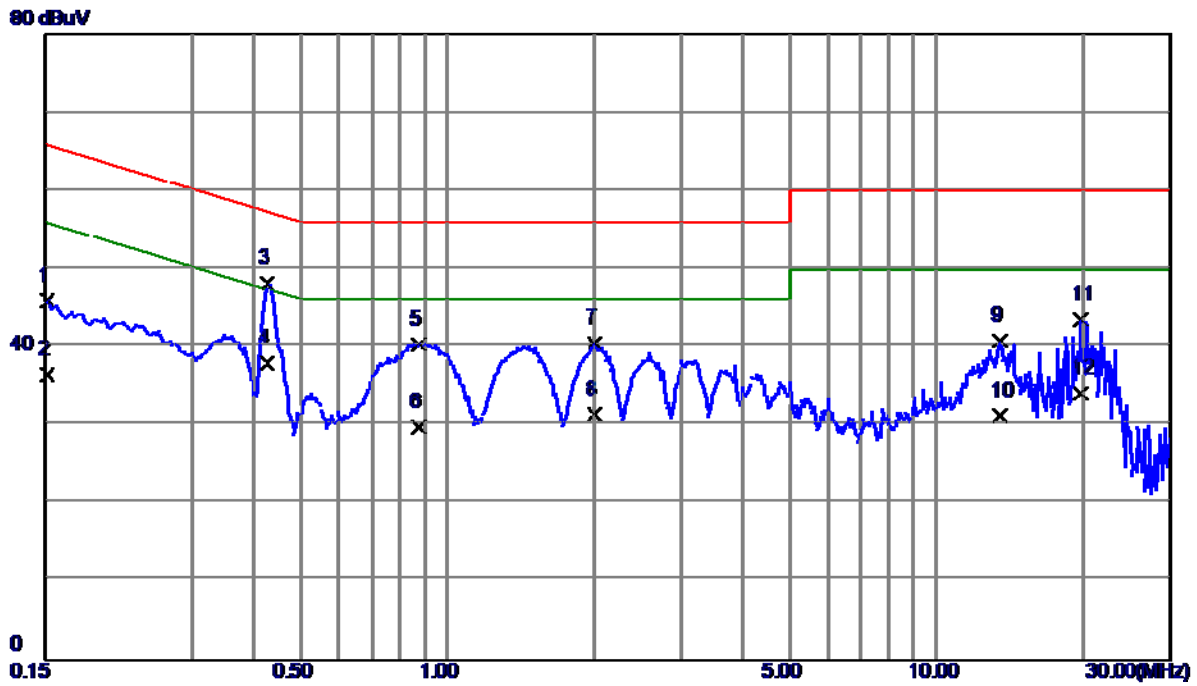

No.	Freq. MHz	Reading Level dBuV	Correct Factor dB	Measure ment dBuV	Limit dBuV	Margin dB	Detector
1	0.1522	36.35	9.64	45.99	65.88	-19.89	QP
2	0.1522	26.90	9.64	36.54	55.88	-19.34	AVG
3 *	0.4290	38.23	9.88	48.11	57.27	-9.16	QP
4	0.4290	28.00	9.88	37.88	47.27	-9.39	AVG
5	0.8722	30.29	10.09	40.38	56.00	-15.62	QP
6	0.8722	19.70	10.09	29.79	46.00	-16.21	AVG
7	2.0018	30.35	10.07	40.42	56.00	-15.58	QP
8	2.0018	21.30	10.07	31.37	46.00	-14.63	AVG
9	13.4790	30.12	10.61	40.73	60.00	-19.27	QP
10	13.4790	20.60	10.61	31.21	50.00	-18.79	AVG
11	19.7093	32.81	10.68	43.49	60.00	-16.51	QP
12	19.7093	23.40	10.68	34.08	50.00	-15.92	AVG

EUT	IP Phone	Model Name	H5
Temperature	25°C	Relative Humidity	53%
Test Voltage	AC 230V/50Hz	Phase	Neutral
Test Mode	Handfree		
Test Engineer	Kevin Li		

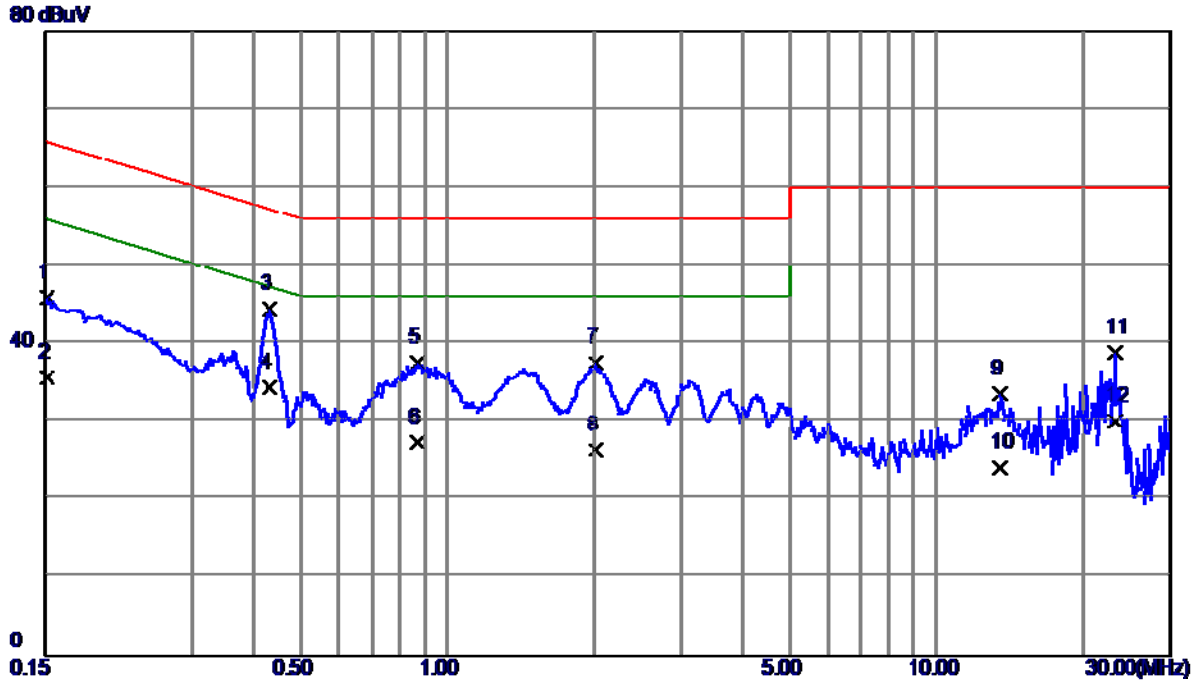

No.	Freq. MHz	Reading Level dBuV	Correct Factor dB	Measurement dBuV	Limit dBuV	Margin dB	Detector
1	0.1522	36.44	9.54	45.98	65.88	-19.90	QP
2	0.1522	26.20	9.54	35.74	55.88	-20.14	AVG
3 *	0.4335	34.63	9.78	44.41	57.19	-12.78	QP
4	0.4335	24.60	9.78	34.38	47.19	-12.81	AVG
5	0.8655	27.76	9.89	37.65	56.00	-18.35	QP
6	0.8655	17.50	9.89	27.39	46.00	-18.61	AVG
7	2.0063	27.46	10.07	37.53	56.00	-18.47	QP
8	2.0063	16.40	10.07	26.47	46.00	-19.53	AVG
9	13.4813	23.07	10.48	33.55	60.00	-26.45	QP
10	13.4813	13.70	10.48	24.18	50.00	-25.82	AVG
11	23.1293	28.08	10.74	38.82	60.00	-21.18	QP
12	23.1293	19.30	10.74	30.04	50.00	-19.96	AVG

EUT	IP Phone	Model Name	H5
Temperature	25°C	Relative Humidity	53%
Test Voltage	AC 230V/50Hz	Phase	Line
Test Mode	Handset		
Test Engineer	Kevin Li		

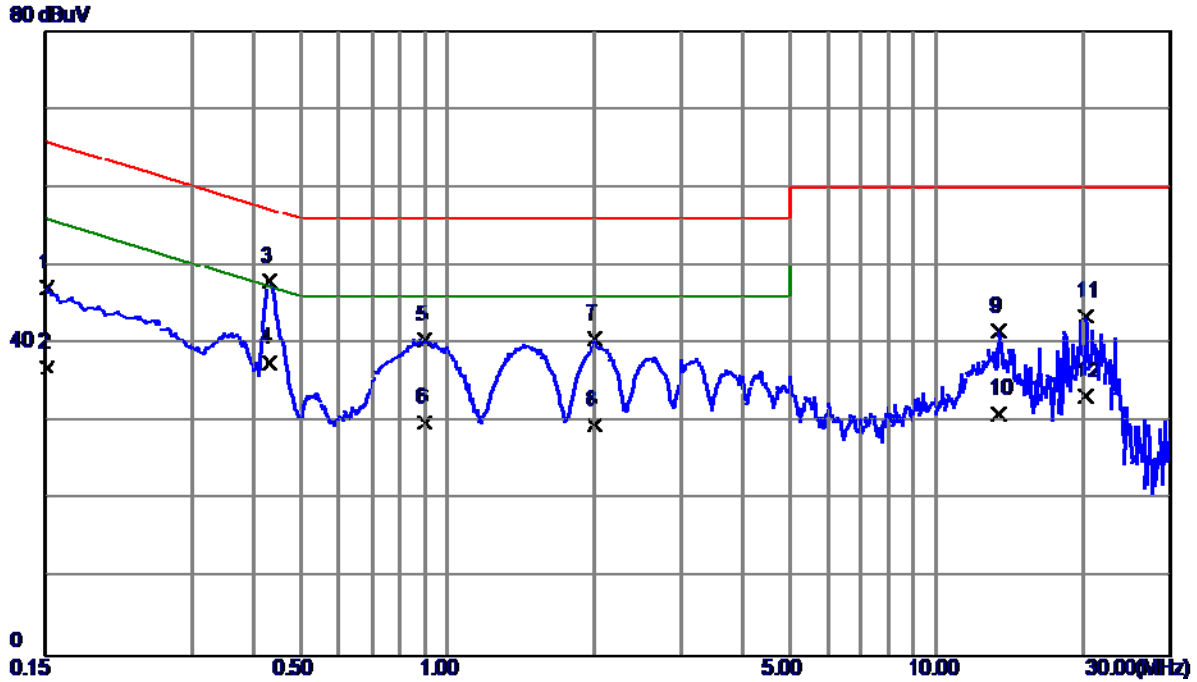

No.	Freq. MHz	Reading Level dBuV	Correct Factor dB	Measure ment dBuV	Limit dBuV	Margin dB	Detector
1	0.1522	37.58	9.64	47.22	65.88	-18.66	QP
2	0.1522	27.30	9.64	36.94	55.88	-18.94	AVG
3 *	0.4335	38.14	9.88	48.02	57.19	-9.17	QP
4	0.4335	27.70	9.88	37.58	47.19	-9.61	AVG
5	0.8970	30.40	10.10	40.50	56.00	-15.50	QP
6	0.8970	19.80	10.10	29.90	46.00	-16.10	AVG
7	2.0018	30.58	10.07	40.65	56.00	-15.35	QP
8	2.0018	19.60	10.07	29.67	46.00	-16.33	AVG
9	13.3575	30.99	10.61	41.60	60.00	-18.40	QP
10	13.3575	20.40	10.61	31.01	50.00	-18.99	AVG
11	20.2583	32.88	10.68	43.56	60.00	-16.44	QP
12	20.2583	22.60	10.68	33.28	50.00	-16.72	AVG

EUT	IP Phone	Model Name	H5
Temperature	25°C	Relative Humidity	53%
Test Voltage	AC 230V/50Hz	Phase	Neutral
Test Mode	Handset		
Test Engineer	Kevin Li		

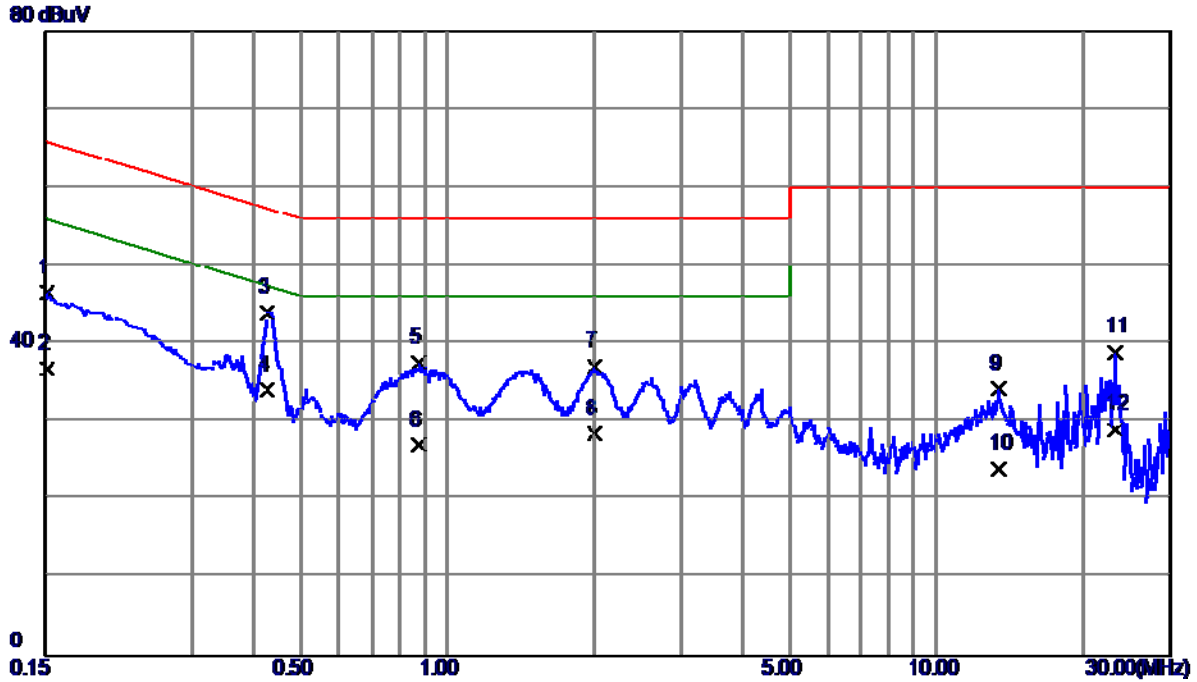

No.	Freq. MHz	Reading Level dBuV	Correct Factor dB	Measure ment dBuV	Limit dBuV	Margin dB	Detector
1	0.1522	37.03	9.54	46.57	65.88	-19.31	QP
2	0.1522	27.30	9.54	36.84	55.88	-19.04	AVG
3	0.4290	34.26	9.78	44.04	57.27	-13.23	QP
4 *	0.4290	24.30	9.78	34.08	47.27	-13.19	AVG
5	0.8745	27.65	9.89	37.54	56.00	-18.46	QP
6	0.8745	17.20	9.89	27.09	46.00	-18.91	AVG
7	1.9995	26.98	10.07	37.05	56.00	-18.95	QP
8	1.9995	18.40	10.07	28.47	46.00	-17.53	AVG
9	13.3598	23.76	10.47	34.23	60.00	-25.77	QP
10	13.3598	13.50	10.47	23.97	50.00	-26.03	AVG
11	23.1293	28.22	10.74	38.96	60.00	-21.04	QP
12	23.1293	18.30	10.74	29.04	50.00	-20.96	AVG

4.3 ASYMMETRIC MODE CONDUCTED EMISSIONS TEST

4.3.1 LIMITS

Requirements for asymmetric mode conducted emissions from Class A equipment

Table clause	Frequency range MHz	Coupling device	Detector type / Bandwidth	Class A voltage limits dB(μV)	Class A current limits dB(μV)
A10.1	0.15 – 0.5	AAN	Quasi Peak / 9 kHz	97 – 87	n/a
	0.5 – 30			87	
	0.15 – 0.5	AAN	Average / 9 kHz	84 – 74	
	0.5 – 30			74	
A10.2	0.15 – 0.5	CVP and current probe	Quasi Peak / 9 kHz	97 – 87	53 – 43
	0.5 – 30			87	43
	0.15 – 0.5	CVP and current probe	Average / 9 kHz	84 – 74	40 – 30
	0.5 – 30			74	30
A10.3	0.15 – 0.5	Current probe	Quasi Peak / 9 kHz	n/a	53 – 43
	0.5 – 30				43
	0.15 – 0.5	Current probe	Average / 9 kHz		40 – 30
	0.5 – 30				30

Requirements for asymmetric mode conducted emissions from Class B equipment

Table clause	Frequency range MHz	Coupling device	Detector type / Bandwidth	Class B voltage limits dB(μV)	Class B current limits dB(μV)
A11.1	0.15 – 0.5	AAN	Quasi Peak / 9 kHz	84 – 74	n/a
	0.5 – 30			74	
	0.15 – 0.5	AAN	Average / 9 kHz	74 – 64	
	0.5 – 30			64	
A11.2	0.15 – 0.5	CVP and current probe	Quasi Peak / 9 kHz	84 – 74	40 – 30
	0.5 – 30			74	30
	0.15 – 0.5	CVP and current probe	Average / 9 kHz	74 – 64	30 – 20
	0.5 – 30			64	20
A11.3	0.15 – 0.5	Current probe	Quasi Peak / 9 kHz	n/a	40 – 30
	0.5 – 30				30
	0.15 – 0.5	Current probe	Average / 9 kHz		30 – 20
	0.5 – 30				20

NOTE:

(1) The test result calculated as following:

Measurement Value = Reading Level + Correct Factor

Correct Factor = Insertion Loss + Cable Loss + Attenuator Factor(if use)

Margin Level = Measurement Value – Limit Value

4.3.2 MEASUREMENT INSTRUMENTS LIST

Item	Kind of Equipment	Manufacturer	Type No.	Serial No.	Calibrated until
1	ISN	FCC	F-070306-1 057-1-09	100362	Mar. 27, 2017
2	Measurement Software	Farad	EZ-EMC Ver.NB-03A 1-01	N/A	N/A
3	50Ω Terminator	SHX	TF2-3G-A	08122901	Mar. 27, 2017
4	TWO-LINE V-NETWORK	R&S	ENV216	100526	Mar. 27, 2017
5	EMI Test Receiver	R&S	ESR3	101862	Sep. 04, 2017
6	Artificial-Mains Network	SCHWARZBECK	NSLK 8127	8127685	Sep. 04, 2017
7	Cable	N/A	RG400 12m	N/A	Mar. 10, 2017

Remark: "N/A" denotes no model name, no serial No. or no calibration specified.

All calibration period of equipment list is one year.

4.3.3 TEST PROCEDURE

- a. The EUT was placed 0.8 meters from the horizontal ground plane with EUT being connected to the power mains through a line impedance stabilization network (LISN). All other support equipment powered from additional LISN(s). The LISN provide 50 Ohm/ 50uH of coupling impedance for the measuring instrument.
- b. Interconnecting cables that hang closer than 40 cm to the ground plane shall be folded back and forth in the center forming a bundle 30 to 40 cm long.
- c. I/O cables that are not connected to a peripheral shall be bundled in the center. The end of the cable may be terminated, if required, using the correct terminating impedance. The overall length shall not exceed 1 m.
- d. For the actual test configuration, please refer to the related Item –EUT Test Photos.
- e. **AAN, CP or CVP** at least 80 cm from nearest part of EUT chassis.

NOTE:

- f. The communication function of EUT was executed and AAN was connected between EUT and associated equipment and the AAN was connected directly to reference ground plane.
Measure the voltage at the measurement port of the AAN
Correct the measured voltage by adding the AAN voltage division factor
Compare the corrected voltage with the limit(**For AAN**)
- g Measure the current with a current probe and compare to the current limit(**For CP**)
- h The current shall be measured with the current probe and the results compared with the current limits.
The voltage measured shall be corrected at each frequency of interest as follows:
- if the current margin with respect to the current limit is ≤ 6 dB, the actual current margin shall be subtracted from the measured voltage;
-if the current margin with respect to the current limit is >6 dB, 6 dB shall be subtracted from the measured voltage.
The adjusted voltage shall be compared with the applicable voltage limit.
Both the measured current and the corrected voltage shall be below the applicable current and voltage limits at all frequencies for the EUT to be deemed compliant with this publication.(**For CVP**)

4.3.4 DEVIATION FROM TEST STANDARD

No deviation

4.3.5 TEST SETUP

a) Cable Type: Balanced Unscreened, Screened or Coaxial

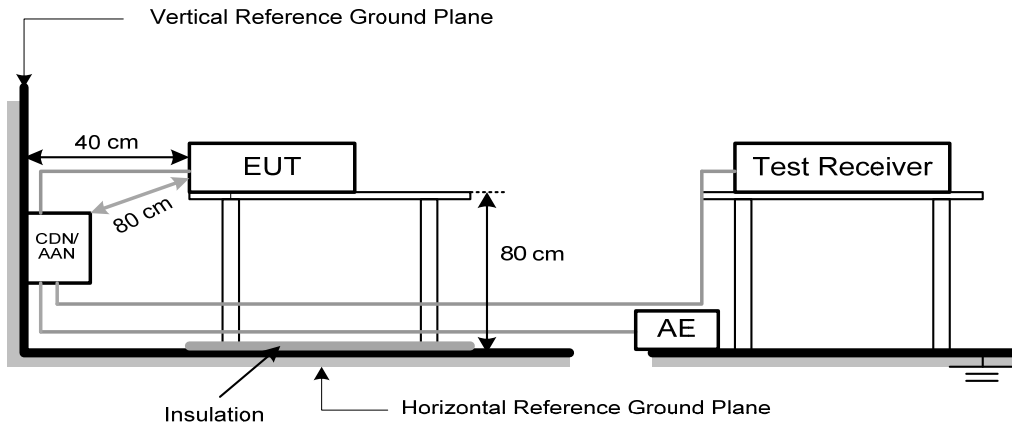

b) Cable Type: Screened or Coaxial

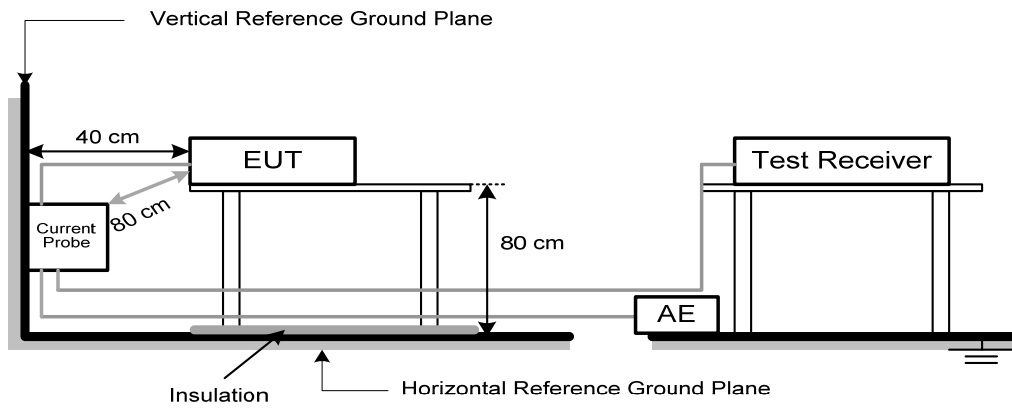

c) Cable Type: Balanced Unscreened, Unbalanced

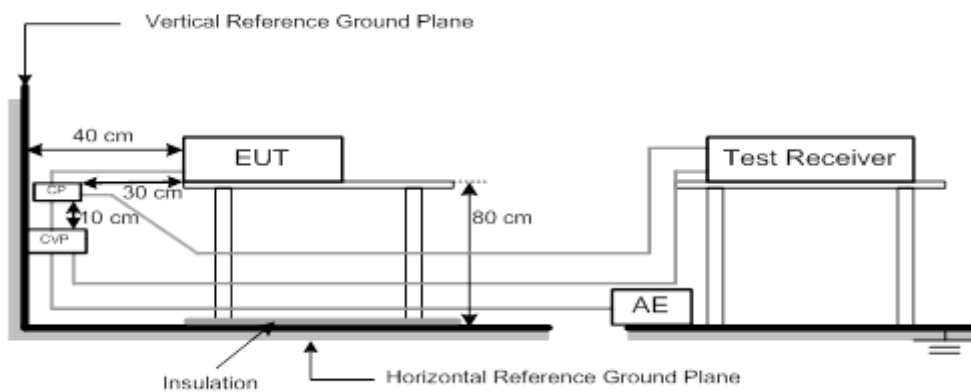

4.3.6 TEST RESULTS

EUT	IP Phone	Model Name	H5
Temperature	25°C	Relative Humidity	53%
Test Voltage	AC 230V/50Hz		
Test Mode	LAN 100Mbps		
Note	Adapter		
Test Engineer	Kevin Li		

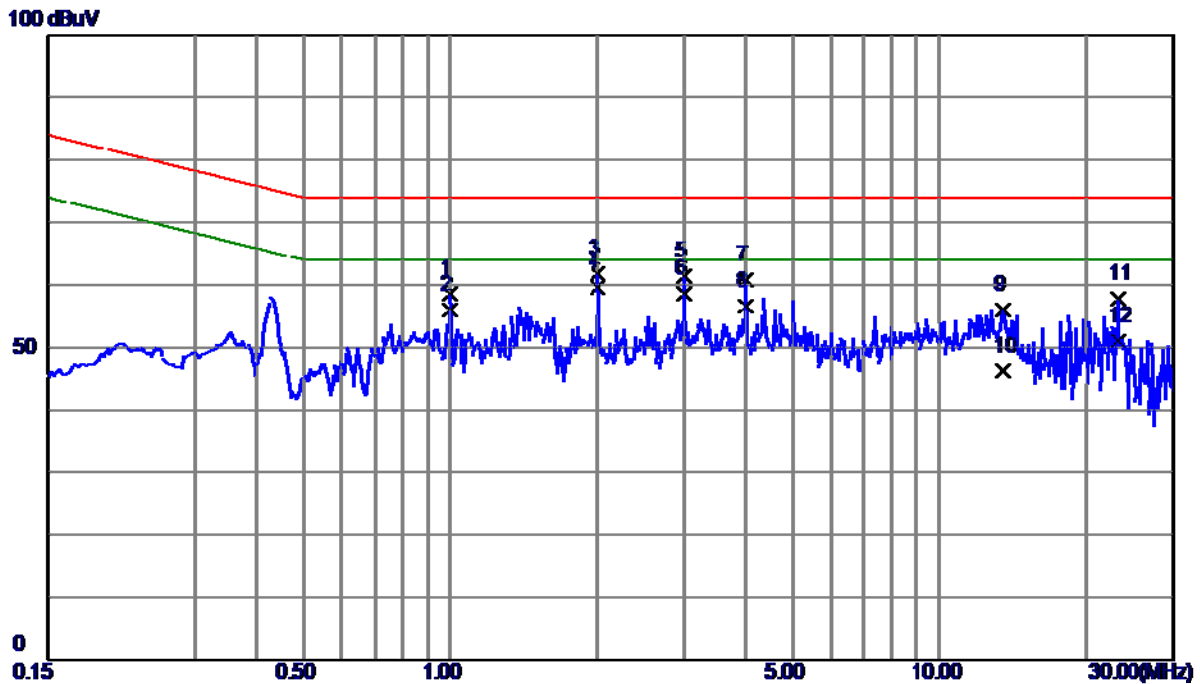

No.	Freq. MHz	Reading Level dBuV	Correct Factor dB	Measure ment dBuV	Limit dBuV	Margin dB	Detector
1	1.0005	48.72	9.83	58.55	74.00	-15.45	QP
2	1.0005	46.20	9.83	56.03	64.00	-7.97	AVG
3	2.0018	51.88	9.88	61.76	74.00	-12.24	QP
4 *	2.0018	49.70	9.88	59.58	64.00	-4.42	AVG
5	3.0030	51.52	9.92	61.44	74.00	-12.56	QP
6	3.0030	48.70	9.92	58.62	64.00	-5.38	AVG
7	4.0043	50.93	9.96	60.89	74.00	-13.11	QP
8	4.0043	46.60	9.96	56.56	64.00	-7.44	AVG
9	13.4790	45.80	10.28	56.08	74.00	-17.92	QP
10	13.4790	35.89	10.28	46.17	64.00	-17.83	AVG
11	23.1293	47.29	10.58	57.87	74.00	-16.13	QP
12	23.1293	40.51	10.58	51.09	64.00	-12.91	AVG

EUT	IP Phone	Model Name	H5
Temperature	25°C	Relative Humidity	53%
Test Voltage	PoE 48V		
Test Mode	LAN 100Mbps		
Note	POE		
Test Engineer	Kevin Li		

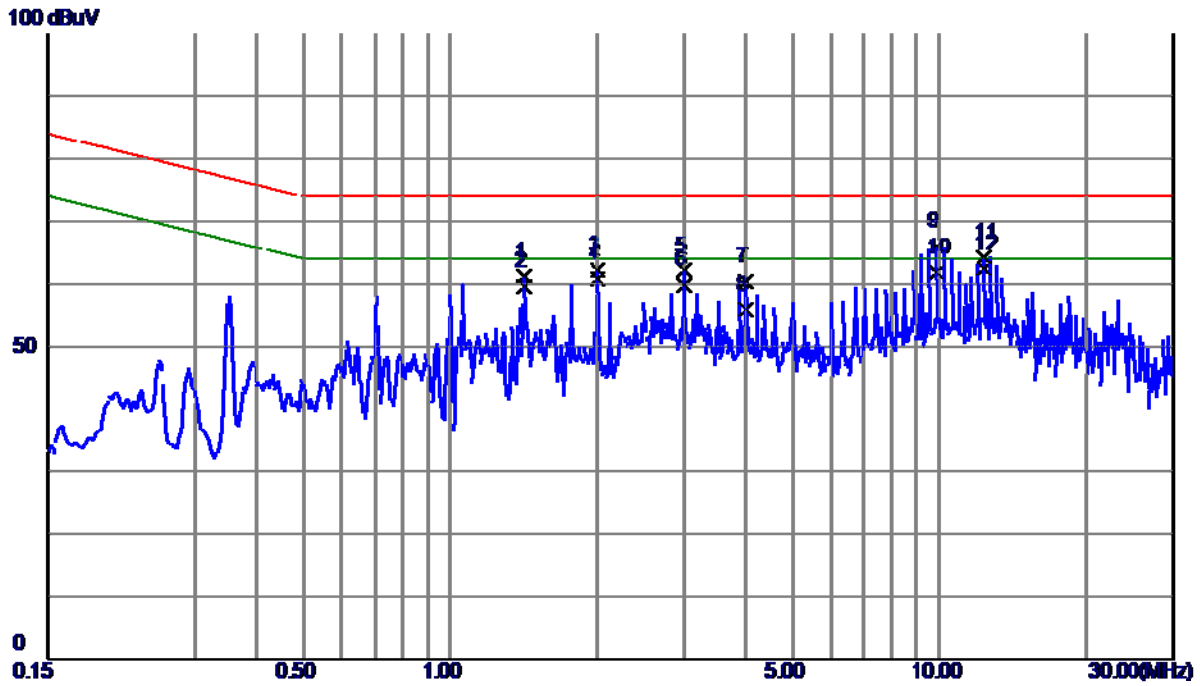

No.	Freq. MHz	Reading Level dBuV	Correct Factor dB	Measure ment dBuV	Limit dBuV	Margin dB	Detector
1	1.4123	51.32	9.85	61.17	74.00	-12.83	QP
2	1.4123	49.80	9.85	59.65	64.00	-4.35	AVG
3	2.0018	52.35	9.88	62.23	74.00	-11.77	QP
4	2.0018	50.90	9.88	60.78	64.00	-3.22	AVG
5	3.0030	52.18	9.92	62.10	74.00	-11.90	QP
6	3.0030	49.90	9.92	59.82	64.00	-4.18	AVG
7	4.0065	50.37	9.96	60.33	74.00	-13.67	QP
8	4.0065	45.80	9.96	55.76	64.00	-8.24	AVG
9	9.8880	55.80	10.16	65.96	74.00	-8.04	QP
10	9.8880	51.70	10.16	61.86	64.00	-2.14	AVG
11	12.3585	53.99	10.24	64.23	74.00	-9.77	QP
12 *	12.3585	52.10	10.24	62.34	64.00	-1.66	AVG

EUT	IP Phone	Model Name	H5
Temperature	25°C	Relative Humidity	53%
Test Voltage	AC 230V/50Hz		
Test Mode	LAN 10Mbps		
Note	Adapter		
Test Engineer	Kevin Li		

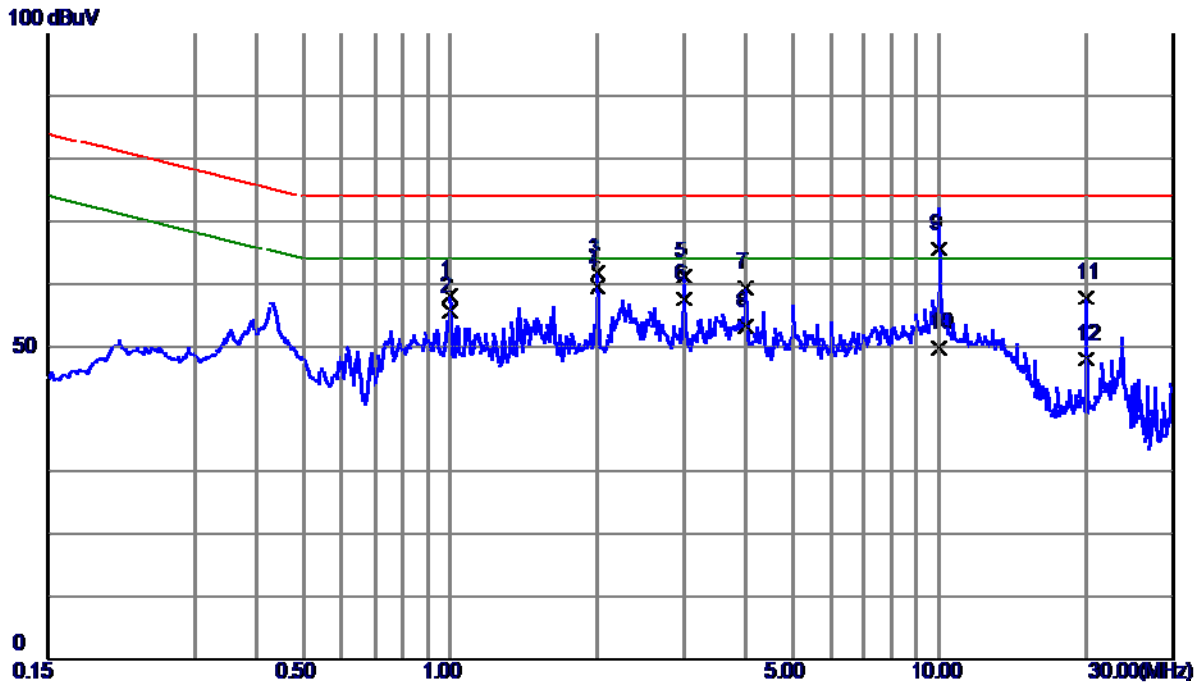

No.	Freq. MHz	Reading Level dBuV	Correct Factor dB	Measure ment dBuV	Limit dBuV	Margin dB	Detector
1	1.0005	48.45	9.83	58.28	74.00	-15.72	QP
2	1.0005	45.70	9.83	55.53	64.00	-8.47	AVG
3	2.0018	51.98	9.88	61.86	74.00	-12.14	QP
4 *	2.0018	49.80	9.88	59.68	64.00	-4.32	AVG
5	3.0030	51.24	9.92	61.16	74.00	-12.84	QP
6	3.0030	47.60	9.92	57.52	64.00	-6.48	AVG
7	4.0065	49.53	9.96	59.49	74.00	-14.51	QP
8	4.0065	43.30	9.96	53.26	64.00	-10.74	AVG
9	10.0004	55.50	10.16	65.66	74.00	-8.34	QP
10	10.0004	39.70	10.16	49.86	64.00	-14.14	AVG
11	20.0018	47.26	10.50	57.76	74.00	-16.24	QP
12	20.0018	37.50	10.50	48.00	64.00	-16.00	AVG

EUT	IP Phone	Model Name	H5
Temperature	25°C	Relative Humidity	53%
Test Voltage	PoE 48V		
Test Mode	LAN 10Mbps		
Note	POE		
Test Engineer	Kevin Li		

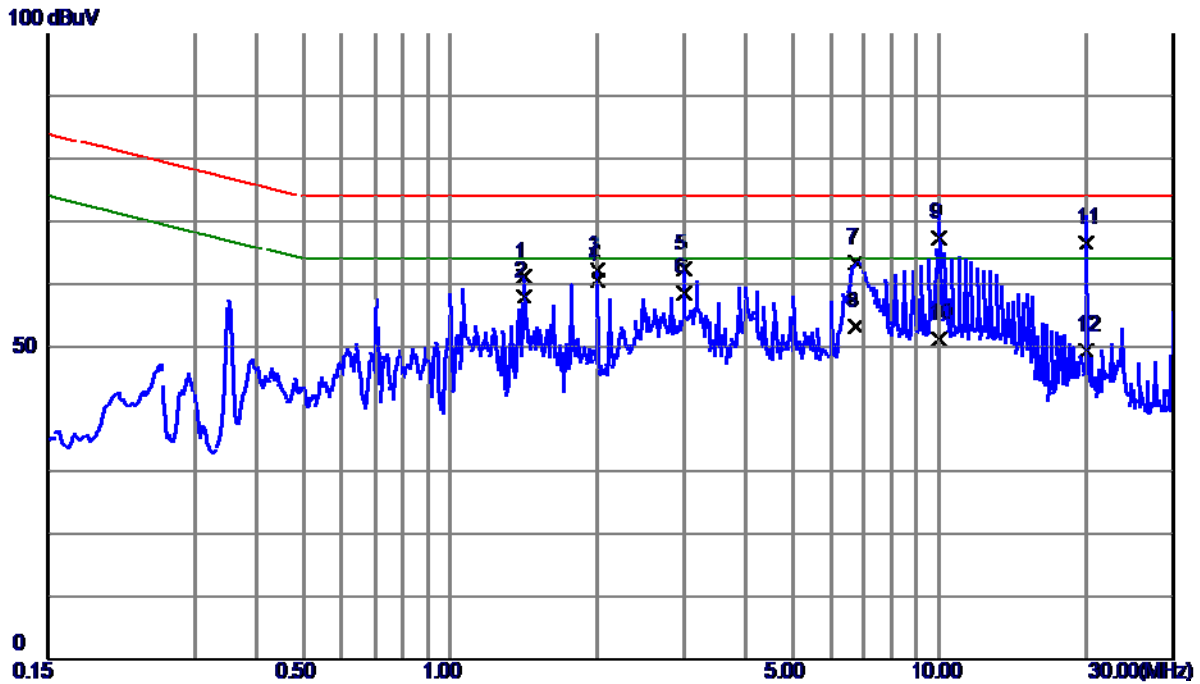

No.	Freq. MHz	Reading Level dBuV	Correct Factor dB	Measure ment dBuV	Limit dBuV	Margin dB	Detector
1	1.4123	51.35	9.85	61.20	74.00	-12.80	QP
2	1.4123	48.10	9.85	57.95	64.00	-6.05	AVG
3	2.0018	52.37	9.88	62.25	74.00	-11.75	QP
4 *	2.0018	50.80	9.88	60.68	64.00	-3.32	AVG
5	3.0008	52.45	9.92	62.37	74.00	-11.63	QP
6	3.0008	48.70	9.92	58.62	64.00	-5.38	AVG
7	6.7110	53.35	10.07	63.42	74.00	-10.58	QP
8	6.7110	43.19	10.07	53.26	64.00	-10.74	AVG
9	10.0004	57.30	10.16	67.46	74.00	-6.54	QP
10	10.0004	41.00	10.16	51.16	64.00	-12.84	AVG
11	20.0018	56.10	10.50	66.60	74.00	-7.40	QP
12	20.0018	38.90	10.50	49.40	64.00	-14.60	AVG

EUT	IP Phone	Model Name	H5
Temperature	25°C	Relative Humidity	53%
Test Voltage	AC 230V/50Hz		
Test Mode	WAN 100Mbps		
Note	Adapter		
Test Engineer	Kevin Li		

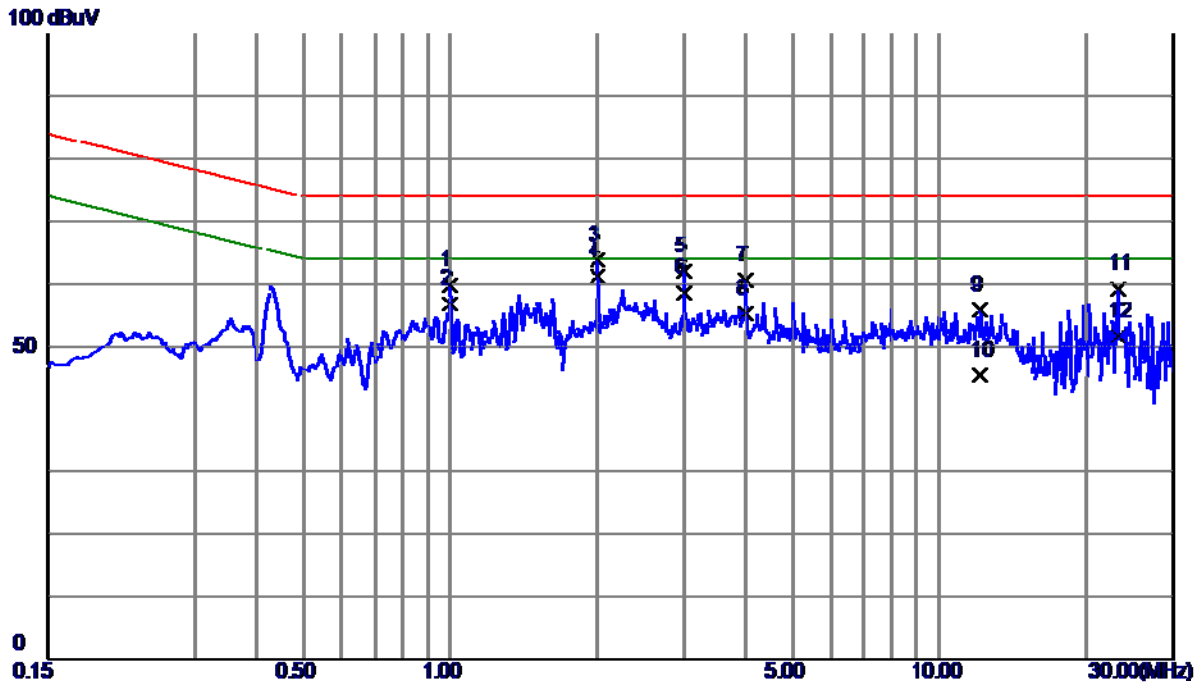

No.	Freq. MHz	Reading Level dBuV	Correct Factor dB	Measure ment dBuV	Limit dBuV	Margin dB	Detector
1	1.0005	49.92	9.83	59.75	74.00	-14.25	QP
2	1.0005	47.00	9.83	56.83	64.00	-7.17	AVG
3	2.0018	53.88	9.88	63.76	74.00	-10.24	QP
4 *	2.0018	51.40	9.88	61.28	64.00	-2.72	AVG
5	3.0030	52.01	9.92	61.93	74.00	-12.07	QP
6	3.0030	48.70	9.92	58.62	64.00	-5.38	AVG
7	4.0043	50.64	9.96	60.60	74.00	-13.40	QP
8	4.0043	45.20	9.96	55.16	64.00	-8.84	AVG
9	12.1358	45.53	10.23	55.76	74.00	-18.24	QP
10	12.1358	35.20	10.23	45.43	64.00	-18.57	AVG
11	23.1293	48.64	10.58	59.22	74.00	-14.78	QP
12	23.1293	41.11	10.58	51.69	64.00	-12.31	AVG

EUT	IP Phone	Model Name	H5
Temperature	25°C	Relative Humidity	53%
Test Voltage	PoE 48V		
Test Mode	WAN 100Mbps		
Note	POE		
Test Engineer	Kevin Li		

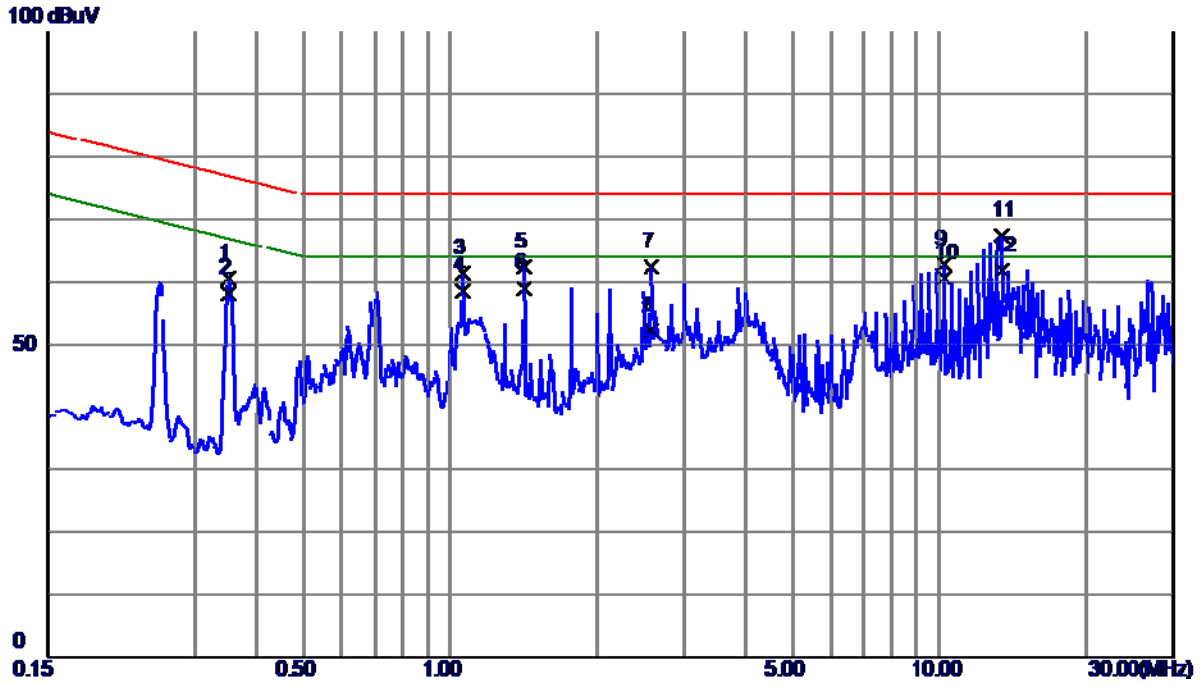

No.	Freq. MHz	Reading Level dBuV	Correct Factor dB	Measure ment dBuV	Limit dBuV	Margin dB	Detector
1	0.3524	51.04	9.64	60.68	76.91	-16.23	QP
2	0.3524	48.50	9.64	58.14	66.91	-8.77	AVG
3	1.0590	51.61	9.83	61.44	74.00	-12.56	QP
4	1.0590	48.80	9.83	58.63	64.00	-5.37	AVG
5	1.4122	52.52	9.85	62.37	74.00	-11.63	QP
6	1.4122	49.20	9.85	59.05	64.00	-4.95	AVG
7	2.5822	52.52	9.90	62.42	74.00	-11.58	QP
8	2.5822	42.31	9.90	52.21	64.00	-11.79	AVG
9	10.2413	52.68	10.17	62.85	74.00	-11.15	QP
10	10.2413	50.50	10.17	60.67	64.00	-3.33	AVG
11	13.4183	57.13	10.28	67.41	74.00	-6.59	QP
12 *	13.4183	51.49	10.28	61.77	64.00	-2.23	AVG

EUT	IP Phone	Model Name	H5
Temperature	25°C	Relative Humidity	53%
Test Voltage	AC 230V/50Hz		
Test Mode	WAN 10Mbps		
Note	Adapter		
Test Engineer	Kevin Li		

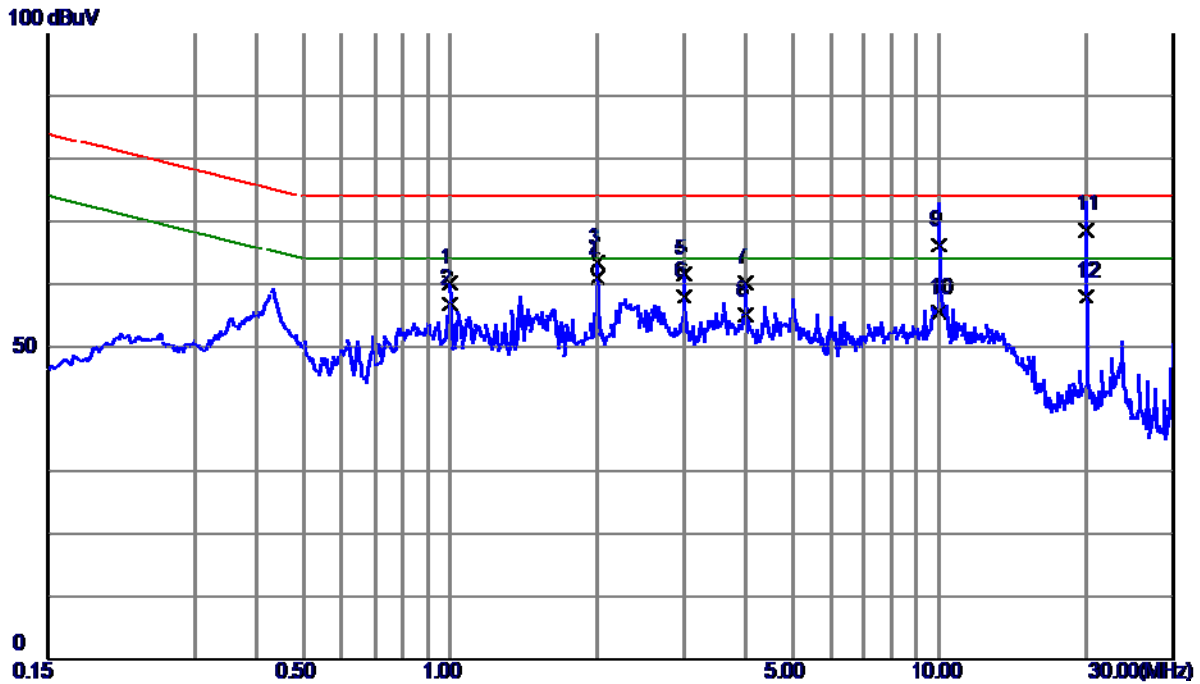

No.	Freq. MHz	Reading Level dBuV	Correct Factor dB	Measure ment dBuV	Limit dBuV	Margin dB	Detector
1	1.0005	50.30	9.83	60.13	74.00	-13.87	QP
2	1.0005	47.00	9.83	56.83	64.00	-7.17	AVG
3	2.0018	53.45	9.88	63.33	74.00	-10.67	QP
4 *	2.0018	51.20	9.88	61.08	64.00	-2.92	AVG
5	3.0030	51.71	9.92	61.63	74.00	-12.37	QP
6	3.0030	48.10	9.92	58.02	64.00	-5.98	AVG
7	4.0065	50.24	9.96	60.20	74.00	-13.80	QP
8	4.0065	45.00	9.96	54.96	64.00	-9.04	AVG
9	10.0004	56.10	10.16	66.26	74.00	-7.74	QP
10	10.0004	45.20	10.16	55.36	64.00	-8.64	AVG
11	20.0018	58.20	10.50	68.70	74.00	-5.30	QP
12	20.0018	47.50	10.50	58.00	64.00	-6.00	AVG

EUT	IP Phone	Model Name	H5
Temperature	25°C	Relative Humidity	53%
Test Voltage	PoE 48V		
Test Mode	WAN 10Mbps		
Note	POE		
Test Engineer	Kevin Li		

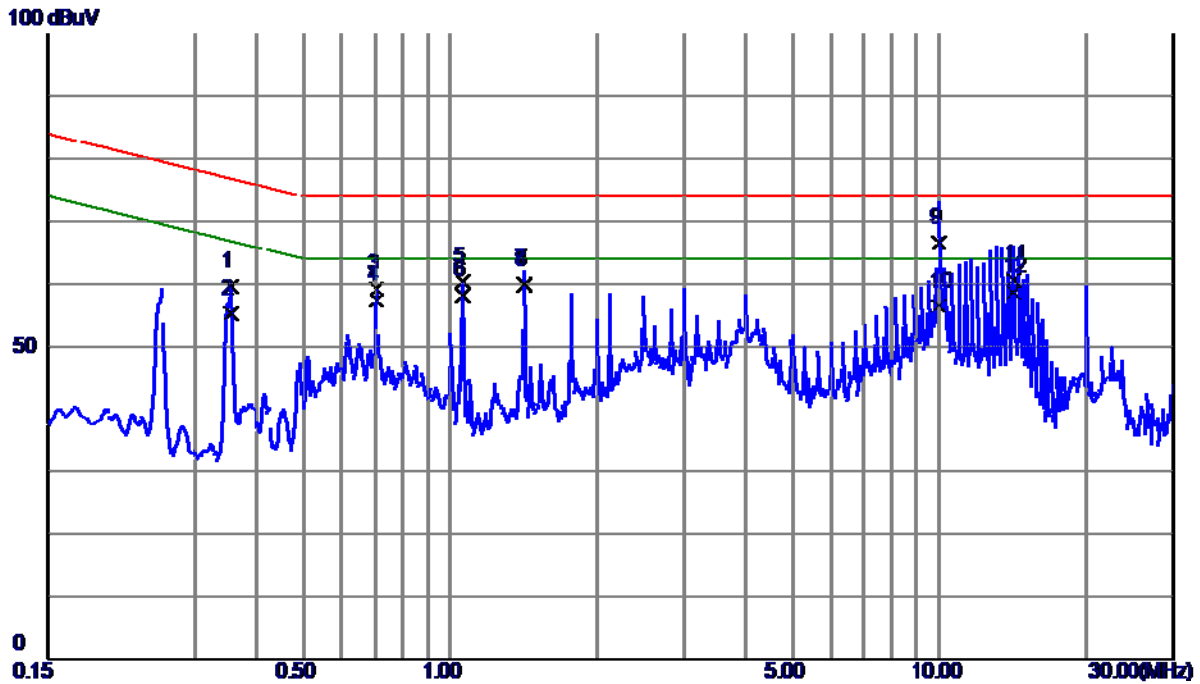

No.	Freq. MHz	Reading Level dBuV	Correct Factor dB	Measure ment dBuV	Limit dBuV	Margin dB	Detector
1	0.3570	49.92	9.64	59.56	76.80	-17.24	QP
2	0.3570	45.50	9.64	55.14	66.80	-11.66	AVG
3	0.7056	49.39	9.76	59.15	74.00	-14.85	QP
4	0.7056	47.60	9.76	57.36	64.00	-6.64	AVG
5	1.0590	50.66	9.83	60.49	74.00	-13.51	QP
6	1.0590	48.40	9.83	58.23	64.00	-5.77	AVG
7	1.4123	50.10	9.85	59.95	74.00	-14.05	QP
8 *	1.4123	50.00	9.85	59.85	64.00	-4.15	AVG
9	10.0004	56.50	10.16	66.66	74.00	-7.34	QP
10	10.0004	46.20	10.16	56.36	64.00	-7.64	AVG
11	14.1248	50.40	10.30	60.70	74.00	-13.30	QP
12	14.1248	48.40	10.30	58.70	64.00	-5.30	AVG

4.4 HARMONIC CURRENT EMISSIONS TEST

4.4.1 LIMITS

EN 61000-3-2						
Equipment Category	Harmonic Order n	Max. Permissible Harmonic Current A	Equipment Category	Harmonic Order n	Max. Permissible Harmonic Current A mA/w	
Class A	Odd Harmonics		Class D	Odd Harmonics only		
	3	2.30		3	2.30	3.4
	5	1.14		5	1.14	1.9
	7	0.77		7	0.77	1.0
	9	0.40		9	0.40	0.5
	11	0.33		11	0.33	0.35
	13	0.21		13	0.21	0.30
	15≤n≤39	0.15 x 15/n		15≤n≤39	0.15 x 15/n	3.85/n
	Even Harmonics					
	2	1.08				
	4	0.43				
	6	0.30				
	8≤n≤40	0.23 x 8/n				

4.4.2 MEASUREMENT INSTRUMENTS LIST

Item	Kind of Equipment	Manufacturer	Type No.	Serial No.	Calibrated until
1	Harmonics and Flicker Analyzer	California Instruments	PACS-1	72344	Jul. 26, 2017
2	3KVA AC Power source	California Instruments	3001ix	56309	Jul. 26, 2017
3	Measurement Software	California	CTS4.0 Version 4.9	N/A	N/A

Remark: "N/A" denotes no model name, no serial No. or no calibration specified.
All calibration period of equipment list is one year.

4.4.3 TEST PROCEDURE

- a. The EUT was placed on the top of a wooden table 0.8 meters above the ground and operated to produce the maximum harmonic components under normal operating conditions.
- b. The classification of EUT is according to of EN 61000-3-2. The EUT is classified as follows:
 - Class A: Balanced three-phase equipment, Household appliances excluding equipment as Class D, Tools excluding portable tools, Dimmers for incandescent lamps, audio equipment, equipment not specified in one of the three other classes.
 - Class B: Portable tools; Arc welding equipment which is not professional equipment.
 - Class C: Lighting equipment.
 - Class D: Equipment having a specified power less than or equal to 600 W of the following types: Personal computers and personal computer monitors and television receivers.
- c. The correspondent test program of test instrument to measure the current harmonics emanated from EUT is chosen. The measure time shall be not less than the time necessary for the EUT to be exercised.

4.4.4 DEVIATION FROM TEST STANDARD

No deviation

4.4.5 TEST SETUP

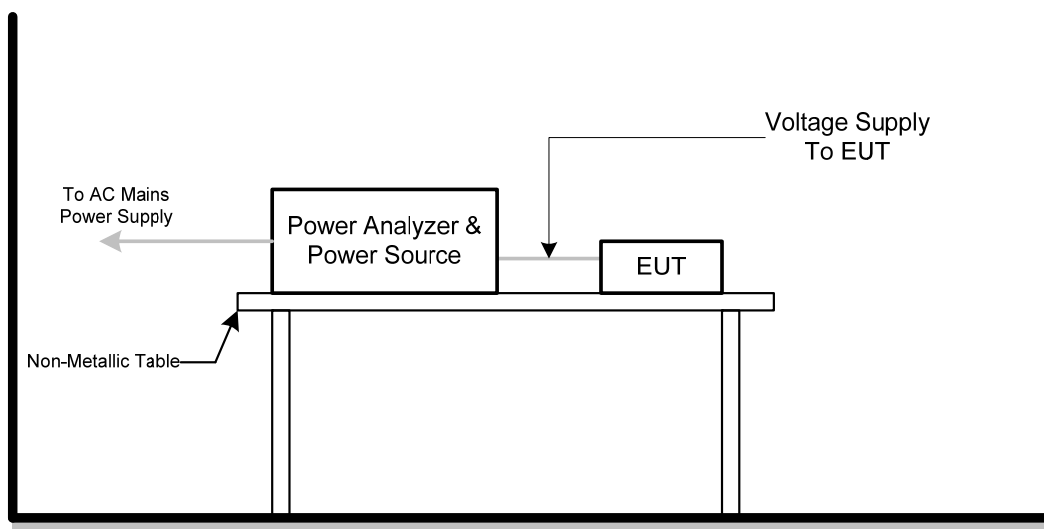

4.4.6 TEST RESULTS

Harmonic - Class A			
EUT	IP Phone	Model Name	H5
Temperature	25°C	Relative Humidity	55%
Test Voltage	AC 230V/50Hz		
Test Mode	Handfree		

Current & voltage waveforms

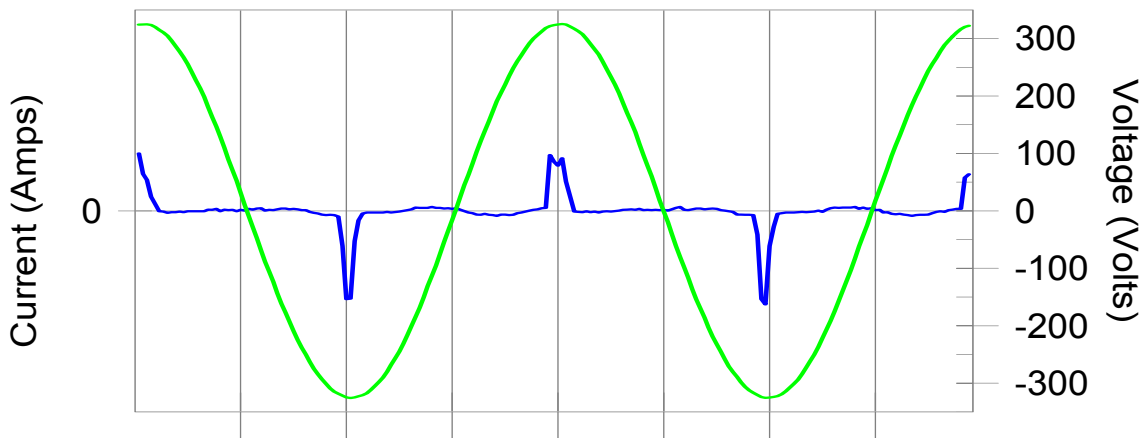

Harmonics and Class A limit line European Limits

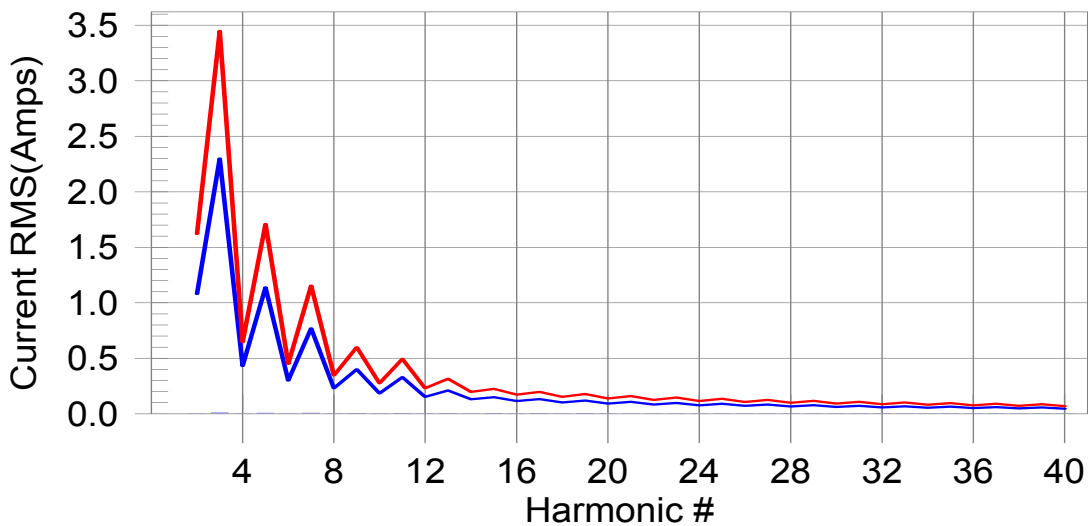

Test result: Pass Worst harmonic was #9 with 0.9% of the limit.

Current Test Result Summary (Run time)			
EUT	IP Phone	Model Name	H5
Temperature	25°C	Relative Humidity	55%
Test Voltage	AC 230V/50Hz		
Test Mode	Handfree		

Highest parameter values during test:

V_RMS (Volts): 230.04	Frequency(Hz): 50.00
I_Peak (Amps): 0.106	I_RMS (Amps): 0.017
I_Fund (Amps): 0.007	Crest Factor: 6.402
Power (Watts): 1.6	Power Factor: 0.438

Harm#	Harms(avg)	100%Limit	%of Limit	Harms(max)	150%Limit	%of Limit	Status
2	0.001	1.080	N/A	0.001	1.620	N/A	Pass
3	0.007	2.300	0.3	0.008	3.450	0.2	Pass
4	0.001	0.430	N/A	0.001	0.645	N/A	Pass
5	0.006	1.140	0.5	0.007	1.710	0.4	Pass
6	0.000	0.300	N/A	0.000	0.450	N/A	Pass
7	0.006	0.770	0.7	0.006	1.155	0.5	Pass
8	0.000	0.230	N/A	0.000	0.345	N/A	Pass
9	0.005	0.400	1.3	0.005	0.600	0.9	Pass
10	0.000	0.184	N/A	0.000	0.276	N/A	Pass
11	0.005	0.330	N/A	0.005	0.495	N/A	Pass
12	0.000	0.153	N/A	0.000	0.230	N/A	Pass
13	0.004	0.210	N/A	0.004	0.315	N/A	Pass
14	0.000	0.131	N/A	0.000	0.197	N/A	Pass
15	0.003	0.150	N/A	0.003	0.225	N/A	Pass
16	0.000	0.115	N/A	0.000	0.173	N/A	Pass
17	0.003	0.132	N/A	0.003	0.198	N/A	Pass
18	0.000	0.102	N/A	0.000	0.153	N/A	Pass
19	0.002	0.118	N/A	0.002	0.178	N/A	Pass
20	0.000	0.092	N/A	0.000	0.138	N/A	Pass
21	0.002	0.107	N/A	0.002	0.161	N/A	Pass
22	0.000	0.084	N/A	0.000	0.125	N/A	Pass
23	0.001	0.098	N/A	0.001	0.147	N/A	Pass
24	0.000	0.077	N/A	0.000	0.115	N/A	Pass
25	0.001	0.090	N/A	0.001	0.135	N/A	Pass
26	0.000	0.071	N/A	0.000	0.107	N/A	Pass
27	0.001	0.083	N/A	0.001	0.125	N/A	Pass
28	0.000	0.066	N/A	0.000	0.099	N/A	Pass
29	0.000	0.078	N/A	0.001	0.116	N/A	Pass
30	0.000	0.061	N/A	0.000	0.092	N/A	Pass
31	0.000	0.073	N/A	0.001	0.109	N/A	Pass
32	0.000	0.058	N/A	0.000	0.086	N/A	Pass
33	0.000	0.068	N/A	0.001	0.102	N/A	Pass
34	0.000	0.054	N/A	0.000	0.081	N/A	Pass
35	0.001	0.064	N/A	0.001	0.096	N/A	Pass
36	0.000	0.051	N/A	0.000	0.077	N/A	Pass
37	0.000	0.061	N/A	0.001	0.091	N/A	Pass
38	0.000	0.048	N/A	0.000	0.073	N/A	Pass
39	0.000	0.058	N/A	0.000	0.087	N/A	Pass
40	0.000	0.046	N/A	0.000	0.069	N/A	Pass

Voltage Source Verification Data (Run time)			
EUT	IP Phone	Model Name	H5
Temperature	25°C	Relative Humidity	55%
Test Voltage	AC 230V/50Hz		
Test Mode	Handfree		

Highest parameter values during test:

Voltage (Vrms):230.04	Frequency(Hz): 50.00
I_Peak (Amps):0.106	I_RMS (Amps): 0.017
I_Fund (Amps):0.007	Crest Factor: 6.402
Power (Watts): 1.6	Power Factor: 0.438

Harm#	Harmonics V-rms	Limit V-rms	% of Limit	Status
2	0.118	0.460	25.58	OK
3	0.606	2.070	29.28	OK
4	0.052	0.460	11.35	OK
5	0.115	0.920	12.55	OK
6	0.020	0.460	4.26	OK
7	0.032	0.690	4.69	OK
8	0.017	0.460	3.68	OK
9	0.032	0.460	6.94	OK
10	0.021	0.460	4.62	OK
11	0.020	0.230	8.59	OK
12	0.014	0.230	5.89	OK
13	0.016	0.230	6.77	OK
14	0.007	0.230	3.09	OK
15	0.014	0.230	6.16	OK
16	0.015	0.230	6.60	OK
17	0.013	0.230	5.56	OK
18	0.016	0.230	7.02	OK
19	0.010	0.230	4.38	OK
20	0.013	0.230	5.78	OK
21	0.009	0.230	3.99	OK
22	0.012	0.230	5.43	OK
23	0.012	0.230	5.28	OK
24	0.007	0.230	3.22	OK
25	0.009	0.230	3.91	OK
26	0.009	0.230	3.78	OK
27	0.005	0.230	2.02	OK
28	0.007	0.230	3.23	OK
29	0.007	0.230	3.21	OK
30	0.006	0.230	2.54	OK
31	0.007	0.230	2.88	OK
32	0.006	0.230	2.46	OK
33	0.009	0.230	4.03	OK
34	0.003	0.230	1.51	OK
35	0.004	0.230	1.70	OK
36	0.004	0.230	1.82	OK
37	0.004	0.230	1.75	OK
38	0.003	0.230	1.42	OK
39	0.004	0.230	1.93	OK
40	0.006	0.230	2.62	OK

4.5 VOLTAGE CHANGES, VOLTAGE FLUCTUATIONS AND FLICKER TEST

4.5.1 LIMITS

Tests	Limits	Descriptions
	EN 61000-3-3	
Pst	≤ 1.0 , $T_p = 10$ min.	Short Term Flicker Indicator
Plt	≤ 0.65 , $T_p = 2$ hr.	Long Term Flicker Indicator
dc	$\leq 3.3\%$	Relative Steady-State V-Chang
dmax	$\leq 4\%$	Maximum Relative V-change
d (t)	$\leq 3.3\%$ for > 500 ms	Relative V-change characteristic

4.5.2 MEASUREMENT INSTRUMENTS LIST

Item	Kind of Equipment	Manufacturer	Type No.	Serial No.	Calibrated until
1	Harmonics and Flicker Analyzer	California Instruments	PACS-1	72344	Jul. 26, 2017
2	3KVA AC Power source	California Instruments	3001ix	56309	Jul. 26, 2017
3	Measurement Software	California	CTS4.0 Version 4.9	N/A	N/A

Remark: "N/A" denotes no model name, no serial No. or no calibration specified.

All calibration period of equipment list is one year.

4.5.3 TEST PROCEDURE

- a. Tests was performed according to the Test Conditions/Assessment of Voltage Fluctuations specified in EN 61000-3-3 depend on which standard adopted for compliance measurement.
- b. All types of harmonic current and/or voltage fluctuation in this report are assessed by direct measurement using flicker-meter.

4.5.4 DEVIATION FROM TEST STANDARD

No deviation

4.5.5 TESTSETUP

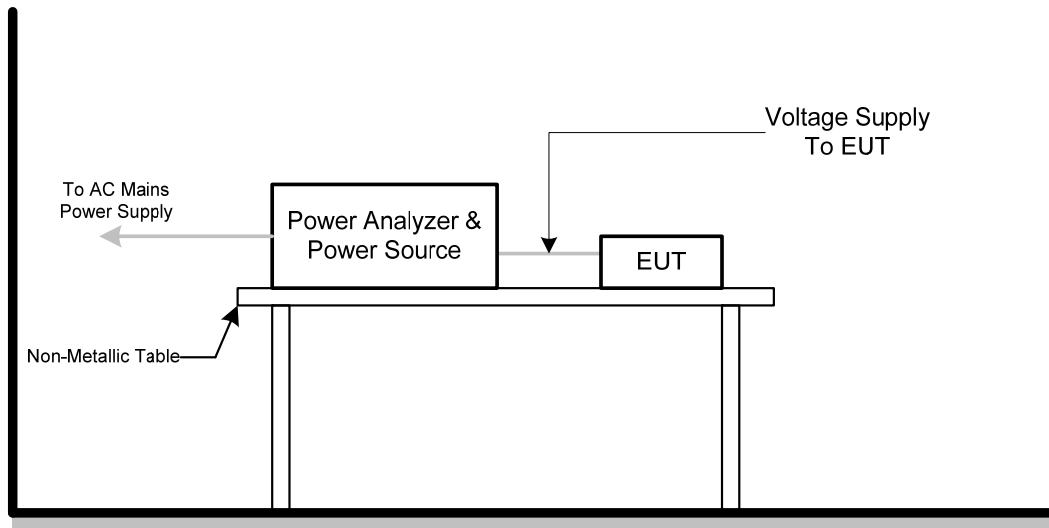

4.5.6 TEST RESULTS

EUT	IP Phone	Model Name	H5
Temperature	25°C	Relative Humidity	55%
Test Voltage	AC 230V/50Hz		
Test Mode	Handfree		

Psti and limit line

European Limits

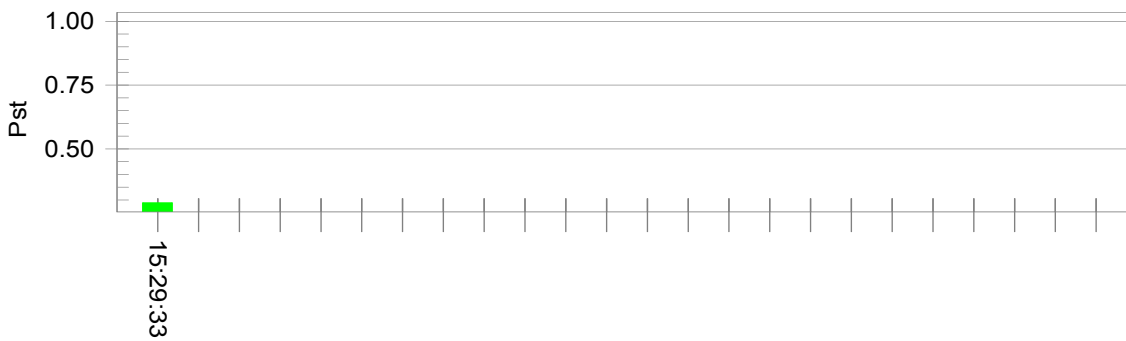

Plt and limit line

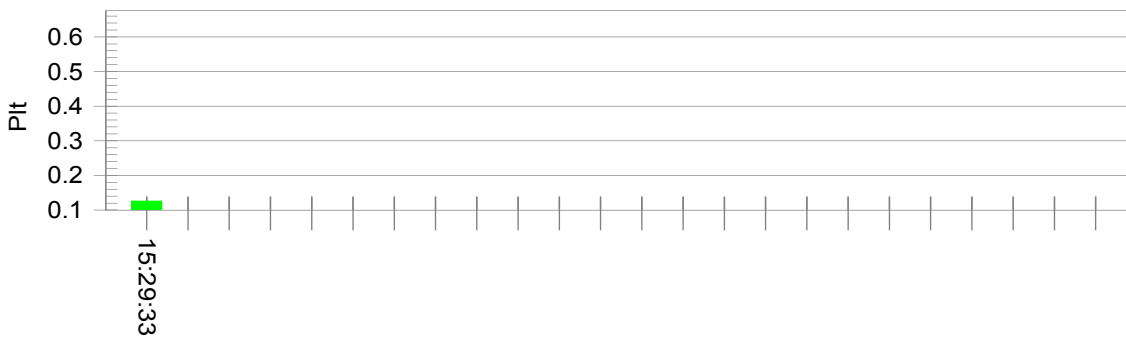

Parameter values recorded during the test:

Vrms at the end of test (Volt):229.93

Highest dt (%):	0.00	Test limit (%):	N/A	N/A
T-max (mS):	0	Test limit (mS):	500.0	Pass
Highest dc (%):	0.00	Test limit (%):	3.30	Pass
Highest dmax (%):	0.05	Test limit (%):	4.00	Pass
Highest Pst (10 min. period):	0.288	Test limit:	1.000	Pass
Highest Plt (2 hr. period):	0.126	Test limit:	0.650	Pass

5. EMC IMMUNITY TEST

5.1 STANDARD COMPLIANCE/SEVERITY LEVEL/CRITERIA

Tests Standard No.	Test Specification Level / Test Mode	Test Ports	Criteria
Electrostatic discharge EN 61000-4-2 (ESD)	±8 kV air discharge ±4 kV contact discharge (Direct Mode)	Enclosure	B
	±4kV HCP discharge ±4kV VCP discharge (Indirect Mode)	Enclosure	B
Radiated, radio-frequency, electromagnetic field immunity EN 61000-4-3 (RS)	80 MHz to 1000 MHz 3V/m(unmodulated, r.m.s), 1 kHz, 80%, AM modulated	Enclosure	A
Electrical fast transient/burst immunity EN 61000-4-4 (EFT/Burst)	±0.5kV(peak) 5/50ns Tr/Th 5kHz Repetition Frequency (100kHz Repetition Frequency for xDSL equipment)	Signal ports and telecommunication ports (Only applicable to cable length>3 m)	B
	±0.5kV(peak) 5/50ns Tr/Th 5kHz Repetition Frequency	DC Power Ports	B
	±1 kV(peak) 5/50ns Tr/Th 5kHz Repetition Frequency	AC Power Ports	B
Surge immunity EN 61000-4-5 (Surges)	±1 kV(peak) 10/700 Tr/Th μs(NOTE) (without primary protection)	Signal ports and telecommunication ports (applicable only to ports connect directly to outdoor cables)	C
	±4 kV(peak) 10/700 Tr/Th μs(NOTE) (with primary protectors fitted)		C
	±0.5 kV(peak) 1.2/50(8/20) Tr/Th μs	DC Power Ports (applicable only to ports connect directly to outdoor cables)	B
	±1 kV(peak) 1.2/50(8/20) Tr/Th μs (line to line)	AC Power Ports	B
	±2 kV(peak) 1.2/50(8/20) Tr/Th μs (line to earth or ground)		B

Immunity to conducted disturbances, induced by radio-frequency fields EN 61000-4-6 (Injected Current)	0.15 MHz to 80 MHz 3V(unmodulated, r.m.s), 1kHz 80%, AM 150Ω source impedance	Signal ports and telecommunication ports (Only applicable to cable length>3 m)	A
	0.15 MHz to 80 MHz 3V(unmodulated, r.m.s), 1kHz 80%, AM 150Ω source impedance	DC Power Ports	A
	0.15 MHz to 80 MHz 3V(unmodulated, r.m.s), 1kHz 80%, AM 150Ω source impedance	AC Power Ports	A
Power frequency magnetic field immunity EN 61000-4-8 (PFMF)	50 Hz or 60Hz, 1A/m(r.m.s) μs	Enclosure	A
Voltage dips, short interruptions and voltage variations immunity EN 61000-4-11 (Voltage Interruption/Dips)	Voltage reduction > 95% 0.5 period Voltage reduction 30% 25 periods Voltage reduction > 95% 250 periods	AC Power Ports	B C C

Note.

Where the coupling network for the 10/700 μs waveform affects the functioning of high speed data ports, the test shall be carried out using a 1,2/50 (8/20) μs waveform and appropriate coupling network.

5.2 GENERAL PERFORMANCE CRITERIA

According to **EN55024** standard, the general performance criteria as following:

<p>Criterion A</p>	<p>The equipment shall continue to operate as intended without operator intervention. No degradation of performance or loss of function is allowed below a performance level specified by the manufacturer when the equipment is used as intended. The performance level may be replaced by a permissible loss of performance.</p> <p>If the minimum performance level or the permissible performance loss is not specified by the manufacturer, then either of these may be derived from the product description and documentation, and by what the user product description and documentation, and by what the user may reasonably expect from the equipment if used as intended.</p>
<p>Criterion B</p>	<p>After the test, the equipment shall continue to operate as intended without operator intervention. No degradation of performance or loss of function is allowed, after the application of the phenomenon below a performance level specified by the manufacturer, when the equipment is used as intended. The performance level may be replaced by a permissible loss of performance.</p> <p>During the test, degradation of performance is allowed. However, no change of operating state if stored data allowed to persist after the test. If the minimum performance level (or the permissible performance loss) is not specified by the manufacturer, then either of these may be derived from the product description and documentation, and by what the user may reasonably expect from the equipment if used as intended.</p>
<p>Criterion C</p>	<p>Loss of function is allowed, provided the function is self-recoverable, or can be restored by the operation of the controls by the user in accordance with the manufacturer's instructions.</p> <p>Functions, and/or information stored in non-volatile memory, or protected by a battery backup, shall not be lost.</p>

5.3 ELECTROSTATIC DISCHARGE IMMUNITY TEST (ESD)

5.3.1 TEST SPECIFICATION

Basic Standard	EN 61000-4-2
Discharge Impedance	330 ohm / 150 pF
Required Performance	B
Discharge Voltage	Air Discharge: ± 2 kV, ± 4 kV, ± 8 kV (Direct) Contact Discharge: ± 2 kV, ± 4 kV (Direct/Indirect)
Polarity	Positive & Negative
Number of Discharge	Air Discharge: min. 20 times at each test point Contact Discharge: min. 200 times in total
Discharge Mode	Single Discharge
Discharge Period	1 second minimum

5.3.2 MEASUREMENT INSTRUMENTS

Item	Kind of Equipment	Manufacturer	Type No.	Serial No.	Calibrated until
1	ESD Generator	TESEQ AG	NSG 437	450	Nov. 03, 2017

Remark: "N/A" denotes no model name, no serial No. or no calibration specified.
All calibration period of equipment list is one year.

5.3.3 TEST PROCEDURE

The test generator necessary to perform direct and indirect application of discharges to the EUT in the following manner:

- a. Contact discharge was applied to conductive surfaces (Direct) and coupling planes (Indirect) of the EUT.

During the test, it was performed with single discharges. For the single discharge time between successive single discharges was at least 1 second. The EUT shall be exposed to at least 200 discharges, 100 each at negative and positive polarity, at a minimum of four test points. One of the test points shall be subjected to at least 50 indirect discharges to the center of the front edge of the horizontal coupling plane. The remaining three test points shall each receive at least 50 direct contact discharges.

If no direct contact test points are available, then at least 200 indirect discharges shall be applied in the indirect mode. Test shall be performed at a maximum repetition rate of one discharge per second.

Vertical Coupling Plane (VCP):

The coupling plane, of dimensions 0.5m x 0.5m, is placed parallel to, and positioned at a distance 0.1m from, the EUT, with the Discharge Electrode touching the coupling plane.

The four faces of the EUT will be performed with electrostatic discharge.

Horizontal Coupling Plane (HCP):

The coupling plane is placed under to the EUT. The generator shall be positioned vertically at a distance of 0.1m from the EUT, with the Discharge Electrode touching the coupling plane.

The four faces of the EUT will be performed with electrostatic discharge.

- b. Air discharges at insulation surfaces of the EUT.

It was at least ten single discharges with positive and negative at the same selected point.

5.3.4 DEVIATION FROM TEST STANDARD

No deviation

5.3.5 TEST SETUP

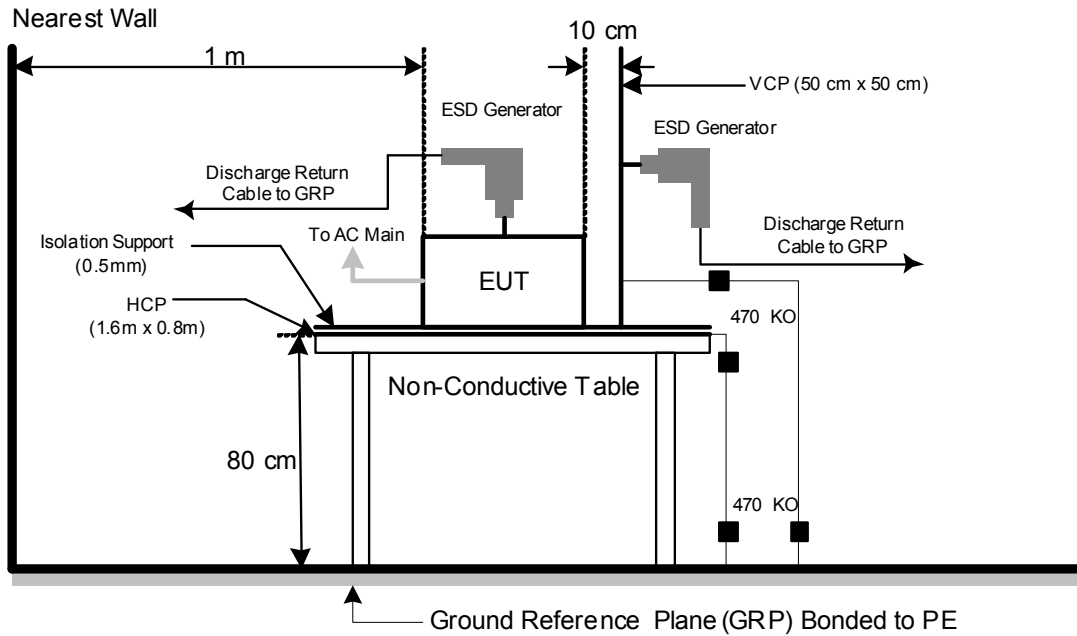

Note:

TABLE-TOP EQUIPMENT

The configuration consisted of a wooden table 0.8 meters high standing on the Ground Reference Plane. The GRP consisted of a sheet of aluminum at least 0.25mm thick, and 2.5 meters square connected to the protective grounding system. A Horizontal Coupling Plane (1.6m x 0.8m) was placed on the table and attached to the GRP by means of a cable with 940k total impedance. The equipment under test was installed in a representative system as described in EN 61000-4-2, and its cables were placed on the HCP and isolated by an insulating support of 0.5mm thickness. A distance of 1-meter minimum was provided between the EUT and the walls of the laboratory and any other metallic structure.

FLOOR-STANDING EQUIPMENT

The equipment under test was installed in a representative system as described in EN 61000-4-2, and its cables were isolated from the Ground Reference Plane by an insulating support of 0.1-meter thickness. The GRP consisted of a sheet of aluminum that is at least 0.25mm thick, and 2.5meters square connected to the protective grounding system and extended at least 0.5 meters from the EUT on all sides.

5.3.6 TEST RESULTS

EUT	IP Phone	Model Name	H5
Temperature	25°C	Relative Humidity	45%
Test Voltage	AC 230V/50Hz	Pressure	1010hPa
Test Mode	Handfree,Handset		

Mode	Air Discharge								Contact Discharge						
	2kV		4kV		8kV		- kV		2kV		4kV		- kV		
Location	P	N	P	N	P	N	P	N	P	N	P	N	P	N	
1	A	A	A	A	A	A	-	-	A	A	A	A	-	-	
2	A	A	A	A	A	A	-	-	-	-	-	-	-	-	
3	A	A	A	A	A	A	-	-	-	-	-	-	-	-	
4	A	A	A	A	A	A	-	-	-	-	-	-	-	-	
5	A	A	A	A	A	A	-	-	-	-	-	-	-	-	
6	A	A	A	A	A	A	-	-	-	-	-	-	-	-	
7	A	A	A	A	A	A	-	-	-	-	-	-	-	-	
8	A	A	A	A	A	A	-	-	-	-	-	-	-	-	
Criteria	B								-		B				-
Result	A								-		A				-
Judgment	PASS								-		PASS				-

Mode	HCP Contact Discharge						VCP Contact Discharge						
	2kV		4kV		- kV		2kV		4kV		- kV		
Location	P	N	P	N	P	N	P	N	P	N	P	N	
1	A	A	A	A	-	-	A	A	A	A	-	-	
2	A	A	A	A	-	-	A	A	A	A	-	-	
3	A	A	A	A	-	-	A	A	A	A	-	-	
4	A	A	A	A	-	-	A	A	A	A	-	-	
Criteria	B						-		B				-
Result	A						-		A				-
Judgment	PASS						-		PASS				-

Note:

- 1) P/N denotes the Positive/Negative polarity of the output voltage.
- 2) Test condition:
 Direct/Indirect(HCP/VCP) discharges: Minimum 50 times (Positive/Negative) at eachpoint.
 Air discharges: Minimum 20 times (Positive/Negative) at each point.
- 3) Test location(s) in which discharge (Air and contact discharge) to be applied illustrated by photos shown in next page(s)
- 4) The Indirect (HCP/VCP) discharges description of test point as following:
 1.left side; 2.right side; 3.front side; 4.rear side.
- 5) N/A - denotes test is not applicable in this test report
- 6) Criterion A: No observation of any performance degradation.
- 7) Criterion B: Some degradation of performance is observed but the equipment continues to operate as intended.
- 8) Criterion C: Loss of functionality, but self-recoverable by user, without loss of information or settings.

PHOTO(S) SHOWN THE LOCATION(S) OF ESD EVALUATED

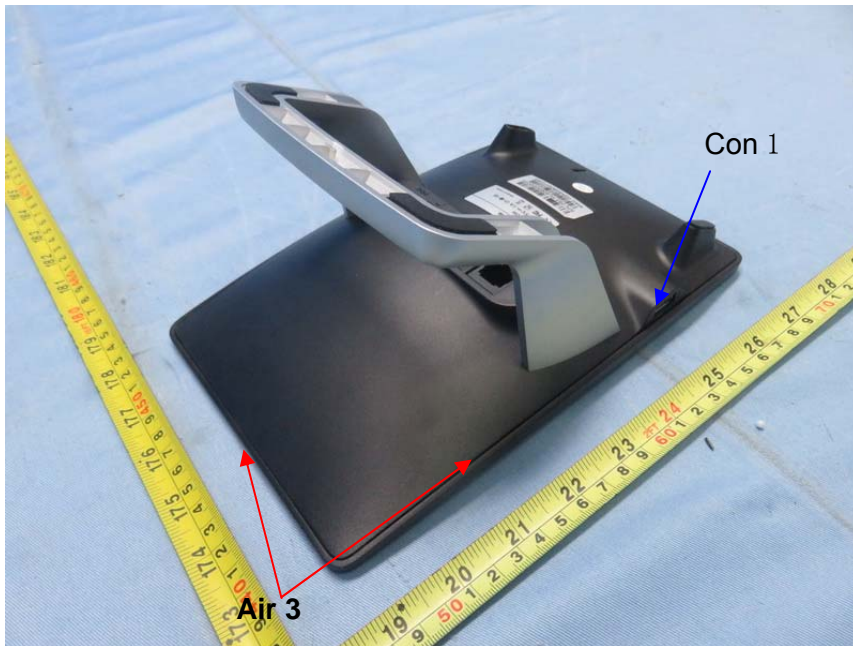



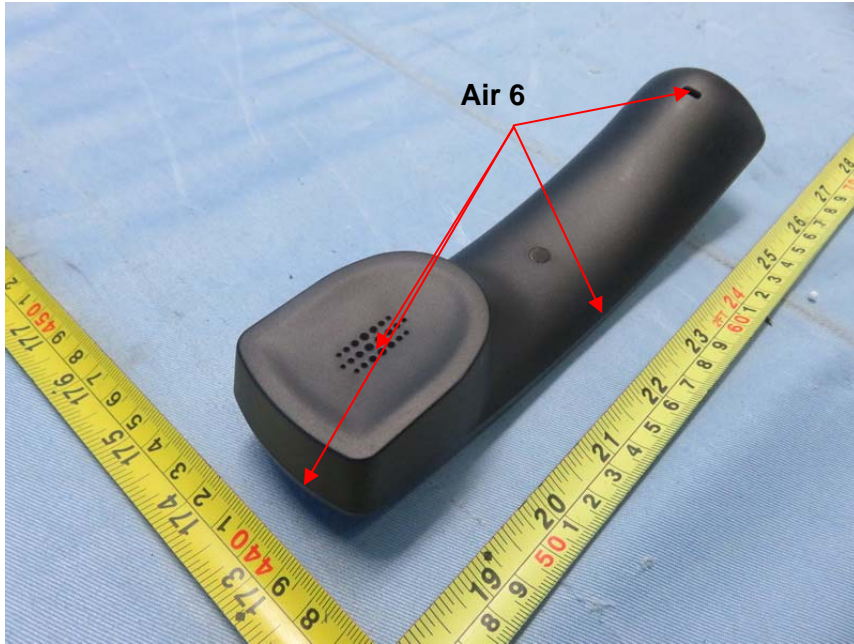

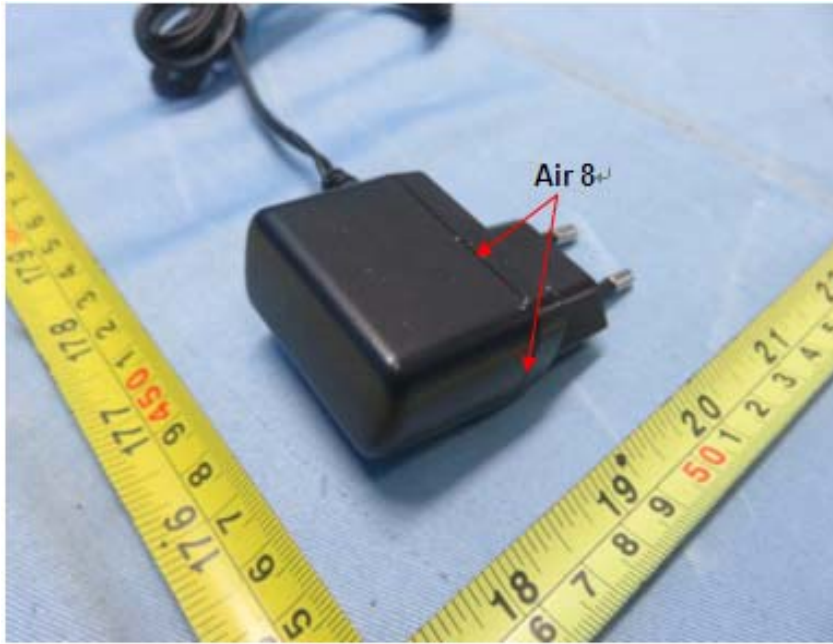

5.4 RADIATED, RADIO-FREQUENCY, ELECTROMAGNETIC FIELD IMMUNITY TEST (RS)

5.4.1 TEST SPECIFICATION

Basic Standard	EN 61000-4-3
Required Performance	A
Frequency Range	80 MHz - 1000 MHz
Field Strength	3 V/m(unmodulated, r.m.s)
Modulation	1 kHz Sine Wave, 80%, AM Modulation
Frequency Step	1% of fundamental
Polarity of Antenna	Horizontal and Vertical
Test Distance	3 m
Antenna Height	1.5 m
Dwell Time	at least 3 seconds

5.4.2 MEASUREMENT INSTRUMENTS

Item	Kind of Equipment	Manufacturer	Type No.	Serial No.	Calibrated until
1	Power amplifier	MILMEGA	80RF1000-250	1064833	Nov. 02, 2017
2	Antenna	ETS	3142C	00047662	Mar. 27, 2017
3	Digital Signal Generator	HP	ESG-D300 0A	US36260188	Mar. 27, 2017
4	Measurement Software	TOYO	IM5/R Ver 3.8.050	N/A	N/A

Remark: "N/A" denotes no model name, no serial No. or no calibration specified.

All calibration period of equipment list is one year.

5.4.3 TEST PROCEDURE

The EUT and support equipment, which are placed on a table that is 0.8 meter above ground and the testing was performed in a fully-anechoic chamber.

The testing distance from antenna to the EUT was 3 meters.

The other condition as following manner:

- a. The field strength level was 3 V/m(unmodulated, r.m.s).
- b. The frequency range is swept from 80 MHz to 1000 MHz, with the signal 80%amplitude modulated with a 1 kHz sine wave. The rate of sweep did not exceed 1.5×10^{-3} decade/s. Where the frequency range is swept incrementally, the step size was 1% of fundamental.
- c. The dwell time at each frequency shall be not less than the time necessary for the EUT to be able to respond.
- d. The test was performed with the EUT exposed to both vertically and horizontally polarized fields on each of the four sides.

5.4.4 DEVIATION FROM TEST STANDARD

No deviation

5.4.5 TEST SETUP

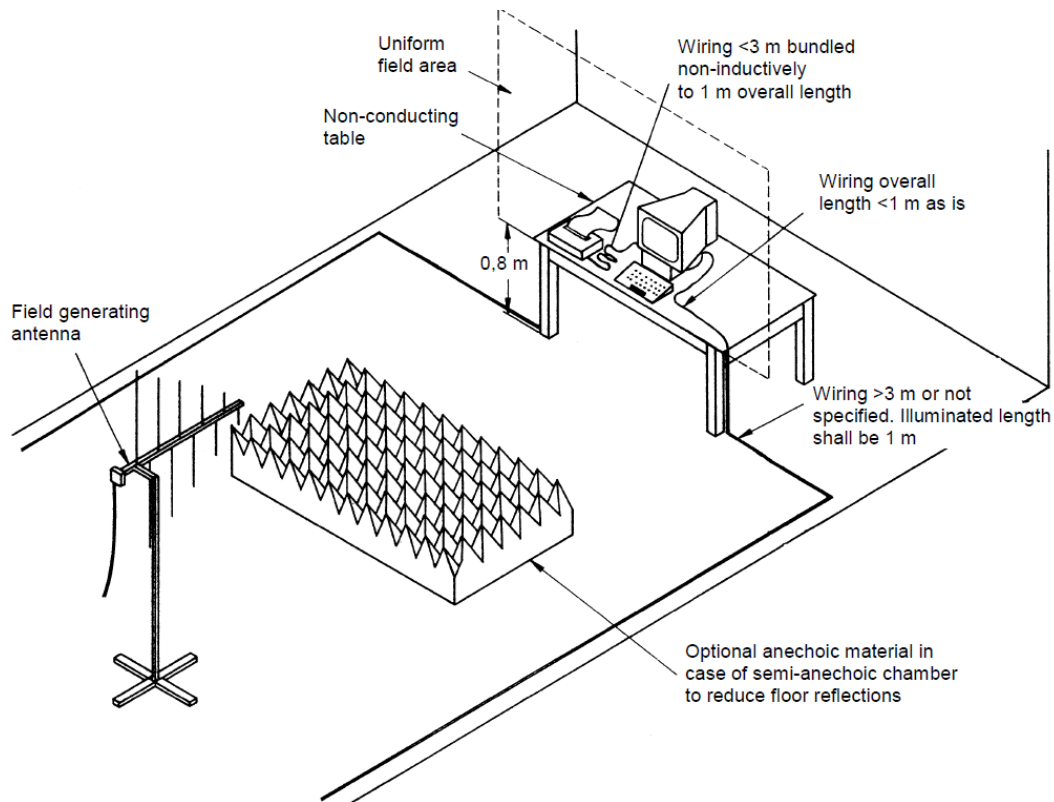

Note:

TABLE-TOP EQUIPMENT

The EUT installed in a representative system as described in EN 61000-4-3 was placed on a non-conductive table 0.8 meters in height. The system under test was connected to the power and signal wire according to relevant installation instructions.

FLOOR-STANDING EQUIPMENT

The EUT installed in a representative system as described in EN 61000-4-3 was placed on a non-conductive wood support 0.1 meters in height. The system under test was connected to the power and signal wire according to relevant installation instructions.

5.4.6 TEST RESULTS

EUT	IP Phone	Model Name	H5
Temperature	25°C	Relative Humidity	52%
Test Voltage	AC 230V/50Hz		
Test Mode	Handfree,Handset		

Frequency Range (MHz)	RF Field Position	R.F. Field Strength	Azimuth	Criterion	Result	Judgment
80 - 1000	H / V	3V (unmodulated, r.m.s) AM Modulated 1000Hz, 80%	0	A	A	PASS
			90			
			180			
			270			

Note:

- 1) P/N denotes the Positive/Negative polarity of the output voltage.
- 2) N/A - denotes test is not applicable in this test report.
- 3) Criterion A: No observation of any performance degradation.
- 4) Criterion B: Some degradation of performance is observed but the equipment continues to operate as intended.
- 5) Criterion C: Loss of functionality, but self-recoverable by user, without loss of information or settings.

5.5 ELECTRICAL FAST TRANSIENT/BURST IMMUNITY TEST (EFT/BURST)

5.5.1 TEST SPECIFICATION

Basic Standard	EN 61000-4-4
Required Performance	B
Test Voltage	Power Line:, ± 1 kV Signal/Control Line: ± 0.5 kV
Polarity	Positive & Negative
Impulse Frequency	5 kHz: except for xDSL equipment 100 kHz: only for single lines of xDSL equipment.
Impulse Wave shape	5/50 ns
Burst Duration	15 ms
Burst Period	300 ms
Test Duration	Not less than 1 min.

5.5.2 MEASUREMENT INSTRUMENTS

Item	Kind of Equipment	Manufacturer	Type No.	Serial No.	Calibrated until
1	Capacitor Clamp	Thermo KeyTek	CCL	0502215	Mar. 27, 2017
2	THE MODULAR SOLUTION FOR 6 KV APPLICATIONS	Teseq	NSG 3060	1423	Sep. 04, 2017
3	Measurement Software	Teseq	Win 3000 Version 1.2.0	N/A	N/A

Remark: "N/A" denotes no model name, no serial No. or no calibration specified.

All calibration period of equipment list is one year.

5.5.3 TEST PROCEDURE

The EUT and support equipment(s) are placed on a table that is 0.8 meter high above a metal ground plane and should be located 0.1 m \pm 0.01m high above the Ground Reference Plane (1m*1m min. and 0.65mm thick min).

The other condition as following manner:

- The length of power cord between the coupling device and the EUT should not exceed 1 meter.
- Both positive and negative polarity discharges were applied.
- The duration time of each test sequential was 1 minute

5.5.4 DEVIATION FROM TEST STANDARD

No deviation

5.5.5 TEST SETUP

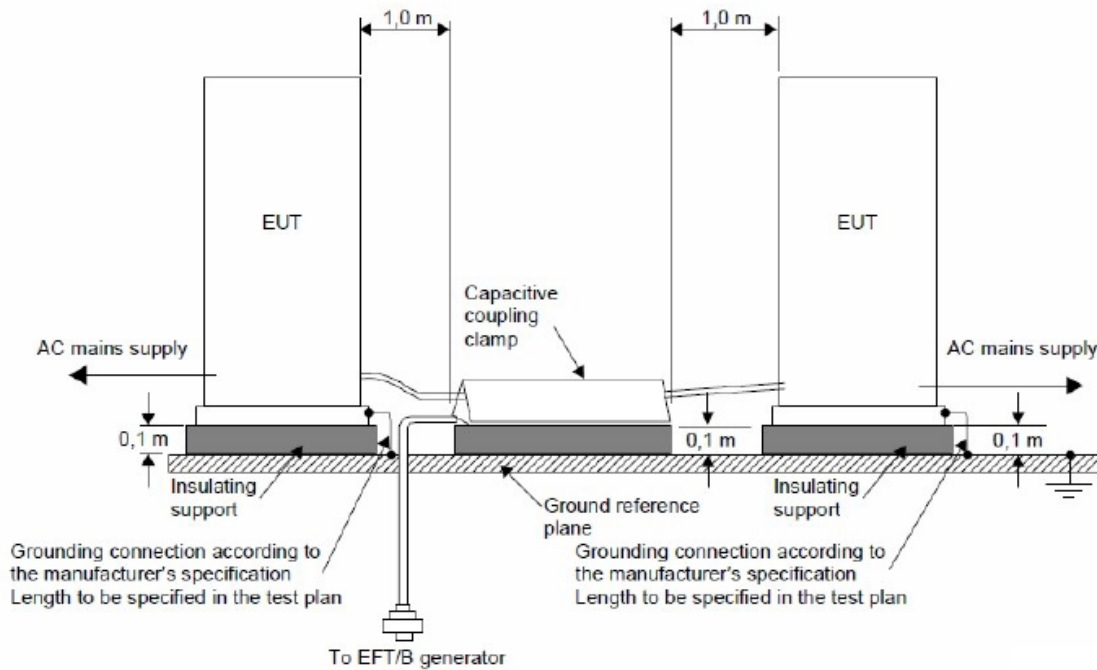
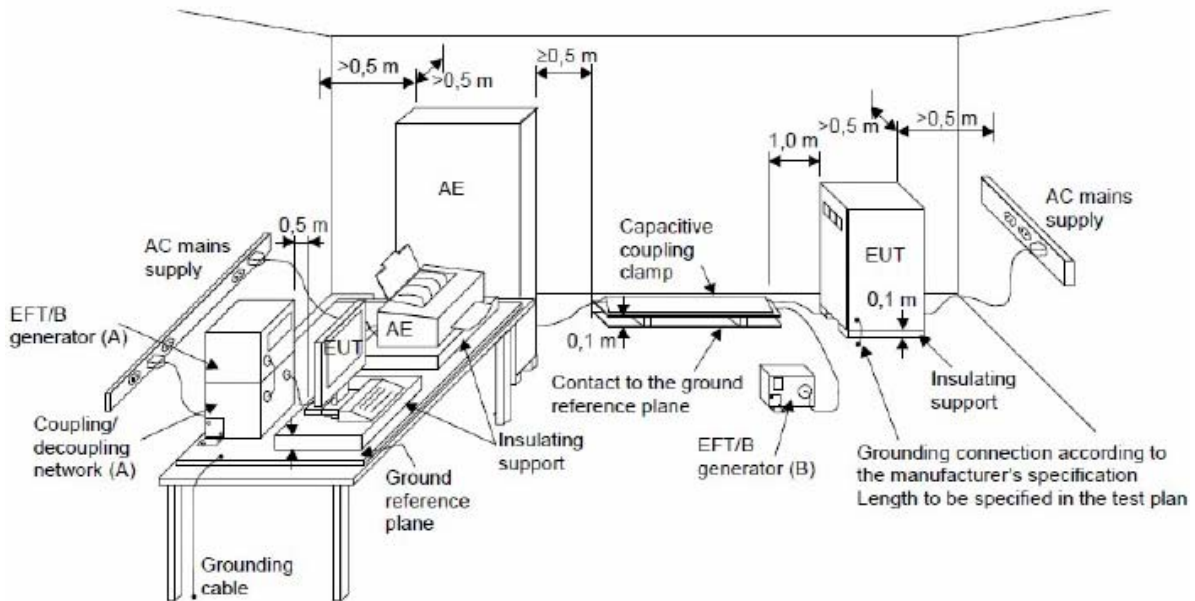

Note:

TABLE-TOP EQUIPMENT

The configuration consisted of a wooden table (0.8m high) standing on the Ground Reference Plane and should be located 0.1 m+/- 0.01m above the Ground Reference Plane. The GRP consisted of a sheet of aluminum (at least 0.25mm thick and 2.5m square) connected to the protective grounding system. A minimum distance of 0.5m was provided between the EUT and the walls of the laboratory or any other metallic structure.

FLOOR-STANDING EQUIPMENT

The EUT installed in a representative system as described in EN 61000-4-4 and its cables were isolated from the Ground Reference Plane by an insulating support that is 0.1-meter thick. The GRP consisted of a sheet of aluminum (at least 0.25mm thick and 2.5m square) connected to the protective grounding system.

5.5.6 TEST RESULTS

EUT	IP Phone	Model Name	H5
Temperature	25°C	Relative Humidity	48%
Test Voltage	AC 230V/50Hz		
Test Mode	Handfree,Handset		

EUT Ports Tested		Polarity	Repetition Frequency	Test Level	Criterion	Result	Judgment
				1kV			
AC Power Port	Line (L)	+	5 kHz	A	B	A	PASS
		-	5 kHz	A			
	Neutral (N)	+	5 kHz	A	B	A	PASS
		-	5 kHz	A			
	Ground (PE)	+	5 kHz	-	B	N/A	N/A
		-	5 kHz	-			

EUT Ports Tested		Polarity	Repetition Frequency	Test Level	Criterion	Result	Judgment
				0.5 kV			
Signal/Data/ Control Port	RJ-45	+	5 kHz	A	B	A	PASS
		-	5 kHz	A			

Note:

- 1) P/N denotes the Positive/Negative polarity of the output voltage.
- 2) N/A - denotes test is not applicable in this test report
- 3) Criterion A: No observation of any performance degradation.
- 4) Criterion B: Some degradation of performance is observed but the equipment continues to operate as intended.
- 5) Criterion C: Loss of functionality, but self-recoverable by user, without loss of information or settings.

5.6 SURGE IMMUNITY TEST

5.6.1 TEST SPECIFICATION

Basic Standard	EN 61000-4-5
Required Performance	B
Wave-Shape	Combination Wave for power lines 1.2/50 us Open Circuit Voltage 8 /20 us Short Circuit Current
Test Voltage	Power Line: ± 0.5 kV, ± 1 kV
Surge Input/Output	L-N
Generator Source Impedance	2 ohm between networks
Polarity	Positive/Negative
Phase Angle:	AC Port: $0^\circ/90^\circ/180^\circ/270^\circ$
Pulse Repetition Rate	1 time / min. (maximum)
Number of Tests	5 positive and 5 negative at selected points

5.6.2 MEASUREMENT INSTRUMENTS

Item	Kind of Equipment	Manufacturer	Type No.	Serial No.	Calibrated until
1	System mainframe	Schaffner	NSG 2050	200729-619 LU	Sep. 04, 2017
2	Signal & Data line coupling network	TEseq	CDN 118	24103	May. 24, 2017
3	THE MODULAR SOLUTION FOR 6 KV APPLICATIONS	Teseq	NSG 3060	1423	Sep. 04, 2017
4	Measurement Software	Teseq	Win 3000 Version 1.2.0	N/A	N/A
5	Measurement Software	Schaffner	Win 2000 Version V7.10	N/A	N/A

Remark: "N/A" denotes no model name, no serial No. or no calibration specified.

All calibration period of equipment list is one year.

5.6.3 TEST PROCEDURE

a. For EUT power supply:

The surge is to be applied to the EUT power supply terminals via the capacitive coupling network. Decoupling networks are required in order to avoid possible adverse effects on equipment not under test that may be powered by the same lines, and to provide sufficient decoupling impedance to the surge wave. The power cord between the EUT and the coupling/decoupling networks shall be 2meters in length (or shorter).

b. For test applied to unshielded unsymmetrically operated interconnection lines of EUT :

The surge is applied to the lines via the capacitive coupling. The coupling /decoupling networks shall not influence the specified functional conditions of the EUT. The interconnection line between the EUT and the coupling/decoupling networks shall be 2 meters in length (or shorter).

c. For test applied to unshielded symmetrically operated interconnection /telecommunication lines of EUT :

The surge is applied to the lines via gas arrestors coupling. Test levels below the ignition point of the coupling arrester cannot be specified. The interconnection line between the EUT and the coupling/decoupling networks shall be 2 meters in length (or shorter).

5.6.4 DEVIATION FROM TEST STANDARD

No deviation

5.6.5 TEST SETUP

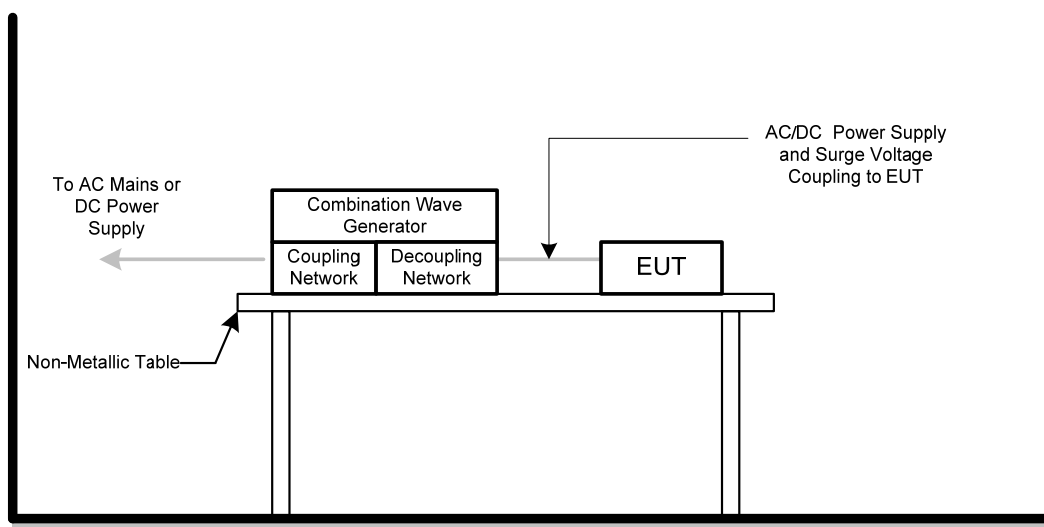

5.6.6 TEST RESULTS

EUT	IP Phone	Model Name	H5
Temperature	25°C	Relative Humidity	48%
Test Voltage	AC 230V/50Hz		
Test Mode	Handfree,Handset		

Wave Form EUT Ports Tested		1.2/50(8/20)Tr/Thµs						Criterion	Result	Judgment
		Polarity	Phase	Voltage						
				0.5kV	1kV	-- kV	-- kV			
AC	L – N (2 ohm)	+/-	0°	A	A	-	-	B	A	PASS
		+/-	90°	A	A	-	-			
		+/-	180°	A	A	-	-			
		+/-	270°	A	A	-	-			

Note:

- 1) Polarity and Numbers of Impulses: 5 Pst / Ngst at each tested mode
- 2) N/A - denotes test is not applicable in this Test Report
- 3) Criterion A: No observation of any performance degradation.
- 4) Criterion B: Some degradation of performance is observed but the equipment continues to operate as intended.
- 5) Criterion C: Loss of functionality, but self-recoverable by user, without loss of information or settings.

5.7 IMMUNITY TO CONDUCTED DISTURBANCES, INDUCED BY RADIO-FREQUENCY FIELDS TEST (CS)

5.7.1 TEST SPECIFICATION

Basic Standard	EN 61000-4-6
Required Performance	A
Frequency Range	0.15 MHz - 80 MHz
Field Strength	3 V (unmodulated, r.m.s.)
Modulation	1 kHz Sine Wave, 80%, AM Modulation
Frequency Step	1% of fundamental
Dwell Time	at least 3 seconds

5.7.2 MEASUREMENT INSTRUMENTS

Item	Kind of Equipment	Manufacturer	Type No.	Serial No.	Calibrated until
1	Measurement Software	TOYO	IM5/C Ver 3.7.028	N/A	N/A
2	Power CDN	FCC	FCC-801-M2/M3-16A	100271	Mar. 27, 2017
3	Power Amplifier	Teseq	CBA230M-080	T43748	Mar. 27, 2017
4	Signal Generator	HP	8648A	3636A02964	Mar. 27, 2017
5	Measurement Software	Farad	EZ-CS(V2.0.1.2)	N/A	N/A
6	Signal Line CDN	FCC	F-090407-1004-1	100518	Mar. 27, 2017

Remark: "N/A" denotes no model name, no serial No. or no calibration specified.

All calibration period of equipment list is one year.

5.7.3 TEST PROCEDURE

The EUT and support equipment, are placed on a table that is 0.8 meter above a metal ground plane measured 1m*1m min. and 0.65mm thick min.

The other condition as following manner:

- a. The field strength level was 3 V (unmodulated, r.m.s.)
- b. The frequency range is swept from 150 kHz to 80 MHz, with the signal 80% amplitude modulated with a 1 kHz sine wave. The rate of sweep did not exceed 1.5×10^{-3} decade/s. Where the frequency range is swept incrementally, the step size was 1% of fundamental.
- c. The dwell time at each frequency shall be not less than the time necessary for the EUT to be able to respond.

5.7.4 DEVIATION FROM TEST STANDARD

No deviation

5.7.5 TEST SETUP

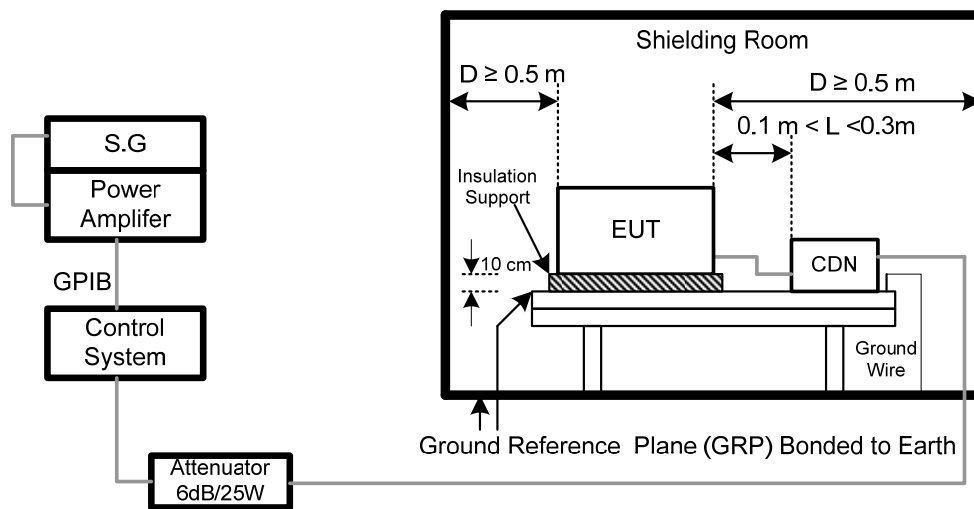

NOTE:

FLOOR-STANDING EQUIPMENT

The equipment to be tested is placed on an insulating support of 0.1 meters height above a ground reference plane. All relevant cables shall be provided with the appropriate coupling and decoupling devices at a distance between 0.1 meters and 0.3 meters from the projected geometry of the EUT on the ground reference plane.

5.7.6 TEST RESULTS

EUT	IP Phone	Model Name	H5
Temperature	25°C	Relative Humidity	52%
Test Voltage	AC 230V/50Hz		
Test Mode	Handfree,Handset		

Test Ports (Mode)	Freq.Range (MHz)	Field Strength	Criteria	Results	Judgment
Input/ Output AC.PowerPort	0.15 ---80	3V(unmodulated, r.m.s) AM Modulated 1000Hz, 80%	A	A	PASS
Input/ Output DC. PowerPort	0.15 --- 80		A	N/A	N/A
Signal Line (RJ45)	0.15 --- 80		A	A	PASS

Note:

- 1). N/A - denotes test is not applicable in this test report.
- 2) Criterion A: No observation of any performance degradation.
- 3) Criterion B: Some degradation of performance is observed but the equipment continues to operate as intended.
- 4) Criterion C: Loss of functionality, but self-recoverable by user, without loss of information or settings.

5.8 POWER FREQUENCY MAGNETIC FIELD IMMUNITY TEST (PFMF)

5.8.1 TEST SPECIFICATION

Basic Standard	EN 61000-4-8
Required Performance	A
Frequency Range	50/60 Hz
Field Strength	1 A/m
Observation Time	1 minute
Inductance Coil	Rectangular type, 1mx1m

5.8.2 MEASUREMENT INSTRUMENTS

Item	Kind of Equipment	Manufacturer	Type No.	Serial No.	Calibrated until
1	Magnetic Field test Generator	FCC	F-1000-4-8-G-125A	04032	Mar. 27, 2017
2	Magnetic Field immunity loop	Thermo KeyTek	F-1000-4-8/9/10-L-1M	04024	Mar. 27, 2017

Remark: "N/A" denotes no model name, no serial No. or no calibration specified.
All calibration period of equipment list is one year.

5.8.3 TEST PROCEDURE

The EUT and support equipment, are placed on a table that is 0.8 meter above a metal ground plane measured 1m*1m min. and 0.65mm thick min.

The other condition as following manner:

- a. The equipment cabinets shall be connected to the safety earth directly on the GRP via the earth terminal of the EUT.
- b. The cables supplied or recommended by the equipment manufacturer shall be used. 1 meter of all cables used shall be exposed to the magnetic field.

5.8.4 DEVIATION FROM TEST STANDARD

No deviation

5.8.5 TEST SETUP

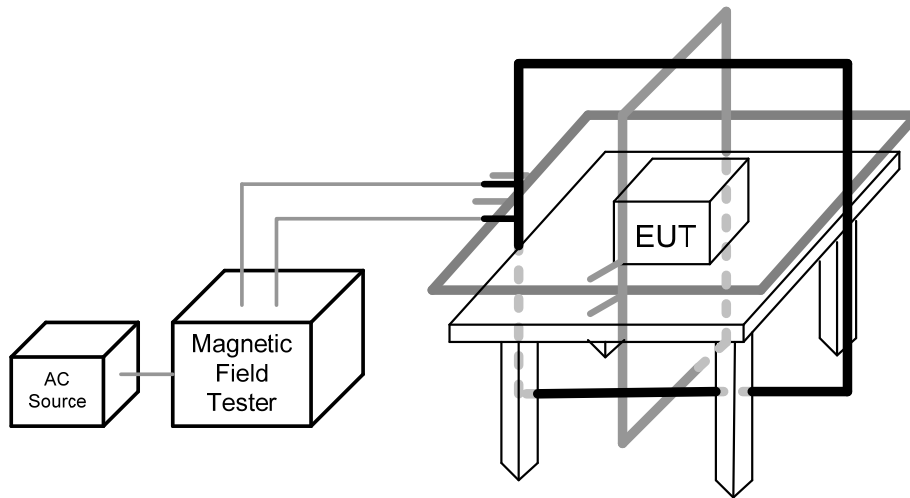

Note:

TABLE-TOP EQUIPMENT

The equipment shall be subjected to the test magnetic field by using the induction coil of standard dimension (1 m x 1 m). The induction coil shall then be rotated by 90 degrees in order to expose the EUT to the test field with different orientations.

FLOOR-STANDING EQUIPMENT

The equipment shall be subjected to the test magnetic field by using induction coils of suitable dimensions. The test shall be repeated by moving and shifting the induction coils, in order to test the whole volume of the EUT for each orthogonal direction. The test shall be repeated with the coil shifted to different positions along the side of the EUT, in steps corresponding to 50 percent of the shortest side of the coil. The induction coil shall then be rotated by 90 degrees in order to expose the EUT to the test field with different orientations.

5.8.6 TEST RESULTS

EUT	IP Phone	Model Name	H5
Temperature	25°C	Relative Humidity	48%
Test Voltage	AC 230V/50Hz		
Test Mode	Handfree,Handset		

50Hz

Test Mode	Test Level	Antenna aspect	Duration (s)	Criteria	Results	Judgment
Enclosure	1 A/m	X	60	A	A	PASS
Enclosure	1 A/m	Y	60	A	A	PASS
Enclosure	1 A/m	Z	60	A	A	PASS

60Hz

Test Mode	Test Level	Antenna aspect	Duration (s)	Criteria	Results	Judgment
Enclosure	1 A/m	X	60	A	A	PASS
Enclosure	1 A/m	Y	60	A	A	PASS
Enclosure	1 A/m	Z	60	A	A	PASS

Note:

- 1). N/A - denotes test is not applicable in this test report.
- 2) Criterion A: No observation of any performance degradation.
- 3) Criterion B: Some degradation of performance is observed but the equipment continues to operate as intended.
- 4) Criterion C: Loss of functionality, but self-recoverable by user, without loss of information or settings.

5.9 VOLTAGE DIPS, SHORT INTERRUPTIONS AND VOLTAGE VARIATIONS IMMUNITY TEST

5.9.1 TEST SPECIFICATION

Basic Standard	EN 61000-4-11
Required Performance	B (For >95% Voltage Dips) C (For 30% Voltage Dips) C (For >95% Voltage Interruptions)
Test Duration Time	Minimum three test events in sequence
Interval between Event	Minimum ten seconds
Phase Angle	0°/180°
Test Cycle	3 times

5.9.2 MEASUREMENT INSTRUMENTS

Item	Kind of Equipment	Manufacturer	Type No.	Serial No.	Calibrated until
1	THE MODULAR SOLUTION FOR 6 KV APPLICATIONS	Teseq	NSG 3060	1423	Sep. 04, 2017
2	Measurement Software	Teseq	Win 3000 Version 1.2.0	N/A	N/A

Remark: "N/A" denotes no model name, no serial No. or no calibration specified.

All calibration period of equipment list is one year.

5.9.3 TEST PROCEDURE

The EUT shall be tested for each selected combination of test levels and duration with a sequence of three dips/interruptions with intervals of 10 s minimum (between each test event). Each representative mode of operation shall be tested. Abrupt changes in supply voltage shall occur at zero crossings of the voltage waveform.

5.9.4 DEVIATION FROM TEST STANDARD

No deviation

5.9.5 TEST SETUP

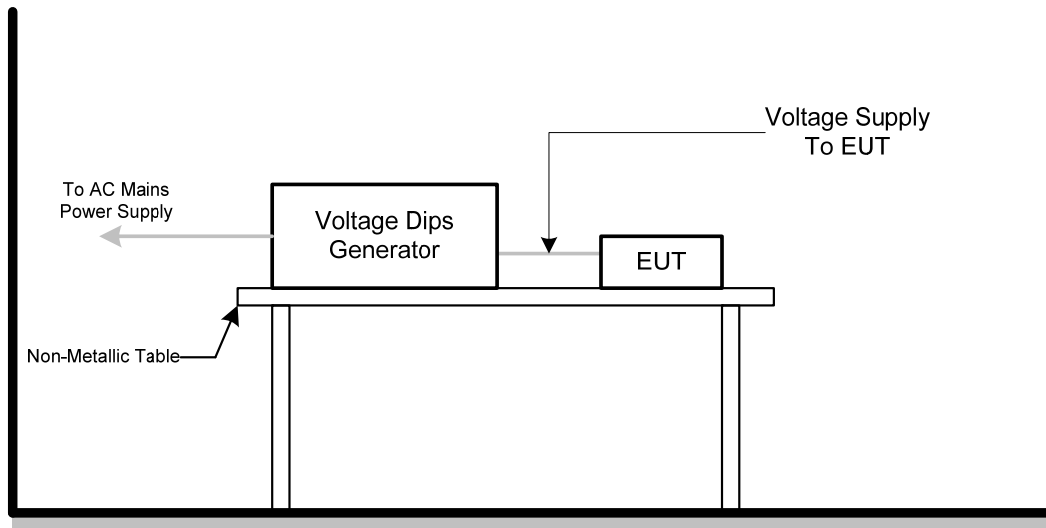

5.9.6 TEST RESULTS

EUT	IP Phone	Model Name	H5
Temperature	25°C	Relative Humidity	48%
Test Voltage	AC 230V/50Hz		
Test Mode	Handfree,Handset		

AC 100V/50Hz				
VoltageReduction	Periods	Criteria	Results	Judgment
Voltage dip >95%	0.5	B	A	PASS
Voltage dip 30%	25	C	A	PASS
Interruption >95%	250	C	C	PASS

AC 230V/50Hz				
VoltageReduction	Periods	Criteria	Results	Judgment
Voltage dip >95%	0.5	B	A	PASS
Voltage dip 30%	25	C	A	PASS
Interruption >95%	250	C	C	PASS

AC 240V/50Hz				
VoltageReduction	Periods	Criteria	Results	Judgment
Voltage dip >95%	0.5	B	A	PASS
Voltage dip 30%	25	C	A	PASS
Interruption >95%	250	C	C	PASS

Note:

- 1). N/A - denotes test is not applicable in this test report.
- 2) Criterion A: No observation of any performance degradation.
- 3) Criterion B: Some degradation of performance is observed but the equipment continues to operate as intended.
- 4) Criterion C: Loss of functionality, but self-recoverable by user, without loss of information or settings.