

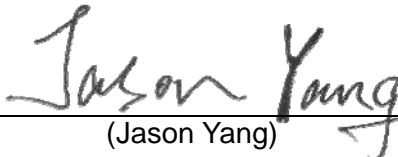
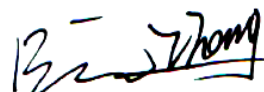

EMC Test Report

Project No. : 1710C220
Equipment : IP Phone
Test Model : E6G
Series Model : F6, F6G
Applicant : Fanvil Technology Co.Ltd
Address : Room 401-403, Building 1, Block 2, Gaoxingqi Industry Park, 67th District, Bao'An, Shenzhen, 518100 P.R. China.

Date of Receipt : Oct. 23, 2017
Date of Test : Oct. 23, 2017 ~ Dec. 20, 2017
Issued Date : Dec. 21, 2017
Tested by : BTL Inc.

Testing Engineer : 
(Jason Yang)

Technical Manager : 
(Bill Zhang)

Authorized Signatory : 
(Tony Li)

B T L I N C .

No.3, Jinshagang 1st Road, Shixia, Dalang Town, Dongguan, Guangdong, China.

TEL: +86-769-8318-3000 FAX: +86-769-8319-6000



Declaration

BTL represents to the client that testing is done in accordance with standard procedures as applicable and that test instruments used has been calibrated with standards traceable to international standard(s) and/or national standard(s).

BTL's reports apply only to the specific samples tested under conditions. It is manufacture's responsibility to ensure that additional production units of this model are manufactured with the identical electrical and mechanical components. **BTL** shall have no liability for any declarations, inferences or generalizations drawn by the client or others from **BTL** issued reports.

BTL's report must not be used by the client to claim product certification, approval, or endorsement by NVLAP, NIST, or any agency of the Federal Government.

This report is the confidential property of the client. As a mutual protection to the clients, the public and **BTL-self**, extracts from the test report shall not be reproduced except in full with **BTL's** authorized written approval.

BTL's laboratory quality assurance procedures are in compliance with the **ISO Guide 17025** requirements, and accredited by the conformity assessment authorities listed in this test report.

Limitation

For the use of the authority's logo is limited unless the Test Standard(s)/Scope(s)/Item(s) mentioned in this test report is (are) included in the conformity assessment authorities acceptance respective.

Table of Contents**Page**

REPORT ISSUED HISTORY	6
1 . CERTIFICATION	7
2 . SUMMARY OF TEST RESULTS	8
2.1 TEST FACILITY	10
2.2 MEASUREMENT UNCERTAINTY	10
3 . GENERAL INFORMATION	12
3.1 GENERAL DESCRIPTION OF EUT	12
3.2 DESCRIPTION OF TEST MODES	13
3.3 EUT OPERATING CONDITIONS	14
3.4 BLOCK DIAGRAM SHOWING THE CONFIGURATION OF SYSTEM TESTED	15
3.5 DESCRIPTION OF SUPPORT UNITS	17
4 . EMC EMISSION TEST	18
4.1 RADIATED EMISSION	18
4.1.1 LIMITS	18
4.1.2 MEASUREMENT INSTRUMENTS LIST	20
4.1.3 TEST PROCEDURE	21
4.1.4 DEVIATION FROM TEST STANDARD	22
4.1.5 TEST SETUP	22
4.1.6 MEASUREMENT DISTANCE	23
4.1.7 TEST RESULTS (UP TO 1 GHZ)	24
4.1.8 TEST RESULTS (ABOVE 1 GHZ)	38
4.2 CONDUCTED EMISSION MEASUREMENT AT AC MAINS POWER PORTS	52
4.2.1 LIMITS	52
4.2.2 MEASUREMENT INSTRUMENTS LIST	52
4.2.3 TEST PROCEDURE	53
4.2.4 DEVIATION FROM TEST STANDARD	53
4.2.5 TEST SETUP	53
4.2.6 TEST RESULTS	54
4.3 ASYMMETRIC MODE CONDUCTED EMISSIONS TEST	62
4.3.1 LIMITS	62
4.3.2 MEASUREMENT INSTRUMENTS LIST	64
4.3.3 TEST PROCEDURE	64
4.3.4 DEVIATION FROM TEST STANDARD	64
4.3.5 TEST SETUP	65
4.3.6 TEST RESULTS	66
4.4 HARMONIC CURRENT EMISSIONS TEST	76
4.4.1 LIMITS	76
4.4.2 MEASUREMENT INSTRUMENTS LIST	76

Table of Contents

Page

4.4.3 TEST PROCEDURE	77
4.4.4 DEVIATION FROM TEST STANDARD	77
4.4.5 TEST SETUP	77
4.4.6 TEST RESULTS	78
4.5 VOLTAGE CHANGES, VOLTAGE FLUCTUATIONS AND FLICKER TEST	81
4.5.1 LIMITS	81
4.5.2 MEASUREMENT INSTRUMENTS LIST	81
4.5.3 TEST PROCEDURE	81
4.5.4 DEVIATION FROM TEST STANDARD	81
4.5.5 TESTSETUP	82
4.5.6 TEST RESULTS	83
5 . EMC IMMUNITY TEST	84
5.1 STANDARD COMPLIANCE/SEVERITY LEVEL/CRITERIA	84
5.2 GENERAL PERFORMANCE CRITERIA	86
5.3 ELECTROSTATIC DISCHARGE IMMUNITY TEST (ESD)	87
5.3.1 TEST SPECIFICATION	87
5.3.2 MEASUREMENT INSTRUMENTS	87
5.3.3 TEST PROCEDURE	87
5.3.4 DEVIATION FROM TEST STANDARD	88
5.3.5 TEST SETUP	88
5.3.6 TEST RESULTS	89
5.4 RADIATED, RADIO-FREQUENCY, ELECTROMAGNETIC FIELD IMMUNITY TEST (RS)	93
5.4.1 TEST SPECIFICATION	93
5.4.2 MEASUREMENT INSTRUMENTS	93
5.4.3 TEST PROCEDURE	93
5.4.4 DEVIATION FROM TEST STANDARD	93
5.4.5 TEST SETUP	94
5.4.6 TEST RESULTS	95
5.5 ELECTRICAL FAST TRANSIENT/BURST IMMUNITY TEST (EFT/BURST)	104
5.5.1 TEST SPECIFICATION	104
5.5.2 MEASUREMENT INSTRUMENTS	104
5.5.3 TEST PROCEDURE	104
5.5.4 DEVIATION FROM TEST STANDARD	104
5.5.5 TEST SETUP	105
5.5.6 TEST RESULTS	106
5.6 SURGE IMMUNITY TEST	107
5.6.1 TEST SPECIFICATION	107
5.6.2 MEASUREMENT INSTRUMENTS	107
5.6.3 TEST PROCEDURE	108
5.6.4 DEVIATION FROM TEST STANDARD	108

Table of Contents	Page
5.6.5 TEST SETUP	108
5.6.6 TEST RESULTS	109
5.7 IMMUNITY TO CONDUCTED DISTURBANCES, INDUCED BY	
RADIO-FREQUENCY FIELDS TEST (CS)	110
5.7.1 TEST SPECIFICATION	110
5.7.2 MEASUREMENT INSTRUMENTS	110
5.7.3 TEST PROCEDURE	110
5.7.4 DEVIATION FROM TEST STANDARD	110
5.7.5 TEST SETUP	111
5.7.6 TEST RESULTS	112
5.8 POWER FREQUENCY MAGNETIC FIELD IMMUNITY TEST (PFMF)	123
5.8.1 TEST SPECIFICATION	123
5.8.2 MEASUREMENT INSTRUMENTS	123
5.8.3 TEST PROCEDURE	123
5.8.4 DEVIATION FROM TEST STANDARD	123
5.8.5 TEST SETUP	124
5.8.6 TEST RESULTS	125
5.9 VOLTAGE DIPS, SHORT INTERRUPTIONS AND VOLTAGE VARIATIONS	
IMMUNITY TEST	126
5.9.1 TEST SPECIFICATION	126
5.9.2 MEASUREMENT INSTRUMENTS	126
5.9.3 TEST PROCEDURE	126
5.9.4 DEVIATION FROM TEST STANDARD	126
5.9.5 TEST SETUP	127
5.9.6 TEST RESULTS	128
6 . EUT TEST PHOTO	129

REPORT ISSUED HISTORY

Issued No.	Description	Issued Date
BTL-EMC-1-1710C220	Original Issue.	Dec. 21, 2017

1. CERTIFICATION

Equipment : IP Phone
Brand Name : Fanvil
Test Model : E6G
Series Model : F6, F6G
Applicant : Fanvil Technology Co.Ltd
Manufacturer : Fanvil Technology Co.Ltd
Address : Room 401-403, Building 1, Block 2, Gaoxinqi Industry Park,67th District,
Bao'An, Shenzhen, 518100 P.R. China.
Factory : Fanvil Technology Co.Ltd
Address : Room 401-403, Building 1, Block 2, Gaoxinqi Industry Park,67th District,
Bao'An, Shenzhen, 518100 P.R. China.
Date of Test : Oct. 23, 2017 ~ Dec. 20, 2017
Test Sample : Engineering Sample
Standard(s) : EN 55032: 2015 Class B
EN 61000-3-2: 2014 Class A
EN 61000-3-3: 2013
EN 55024: 2010+A1:2015
EN 61000-4-2: 2009
EN 61000-4-3: 2006+A1:2008+A2:2010
EN 61000-4-4: 2012
EN 61000-4-5: 2014
EN 61000-4-6: 2014+AC:2015
EN 61000-4-8: 2010
EN 61000-4-11: 2004

The above equipment has been tested and found compliance with the requirement of the relative standards by BTL Inc.

The test data, data evaluation, and equipment configuration contained in our test report (Ref No. BTL-EMC-1-1710C220) were obtained utilizing the test procedures, test instruments, test sites that has been accredited by the Authority of TAF according to the ISO-17025 quality assessment standard and technical standard(s).

2. SUMMARY OF TEST RESULTS

Test procedures according to the technical standards:

Emission					
Standard(s)	Test Item	Limit	Judgment	Remark	
EN 55032: 2015	Radiated emissions up to 1 GHz	Class B	PASS		
	Radiated emissions above 1 GHz	Class B	PASS	NOTE (2)	
	Radiated emissions from FM receivers	-----	N/A	NOTE (1) NOTE (6)	
	Conducted emissions AC mains power port	Class B	PASS	NOTE (7)	
	Asymmetric mode conducted emissions	AAN	-----	PASS	NOTE (1) NOTE (8)
		Current Probe	-----	N/A	
		CVP	-----	N/A	
Conducted differential voltage emissions	-----	N/A	NOTE (1) NOTE (9)		

Standard	Test Item	Limit	Judgment	Remark
EN 61000-3-2:2014	Harmonic current emissions	Class A	PASS	NOTE (3)
EN 61000-3-3:2013	Voltage changes, voltage fluctuations and flicker	-----	PASS	

Immunity EN 55024: 2010+A1:2015				
Section(s)	Test Item	Performance Criterion	Judgment	Remark
EN 61000-4-2:2009	Electrostatic discharge immunity	B	PASS	
EN 61000-4-3: 2006+A1:2008+A2:2010	Radiated, radio-frequency, electromagnetic field immunity	A	PASS	
EN 61000-4-4:2012	Electrical fast transient/burst immunity	B	PASS	
EN 61000-4-5:2014	Surge immunity	B/C	PASS	NOTE (4)
EN 61000-4-6: 2014+AC :2015	Immunity to conducted disturbances, induced by radio-frequency fields	A	PASS	
EN 61000-4-8:2010	Power frequency magnetic field immunity	A	PASS	
EN 61000-4-11:2004	Voltage dips, short interruptions and voltage variations immunity	B / C / C	PASS	NOTE (5)

NOTE:

- (1) "N/A" denotes test is not applicable to this device.
- (2) The EUT's max operating frequency is 333 MHz which does exceed 108 MHz, so the test will be performed.
- (3) If the power consumption is less than 75W, there is no limit applied.
- (4) Performance Criterion C for signal ports and telecommunication ports.
Performance Criterion B for input d.c. power port and a.c. power ports.
- (5) Voltage Dips: > 95% reduction – Performance Criterion B
Voltage Dips: 30% reduction – Performance Criterion C
Voltage Interruptions: > 95% reduction – Performance Criterion C
- (6) If the EUT has FM function the test will be performed.
- (7) If the EUT has AC power mains port the test will be performed.
- (8)

Cable Type	Number of pairs	Measurement type	Procedures
Balanced Unscreened	1 (2 wire) ;2 (4 wire); 3 (6 wire) ;4 (8 wire)	Voltage	AAN
Balanced Unscreened	See a)	Voltage and Current	CP+CVP
Screened or Coaxial	n/a	Voltage	AAN
Screened or Coaxial	n/a	Voltage or Current	CP or CVP
Unbalanced cables	n/a	Voltage and Current	CP+CVP

Ports connected to cables with more than 4 balanced pairs or where the port is unable to function correctly when connected through an AAN.

- (9) If the EUT has tuner port the test will be performed.
- (10)The requirement followed by the client's specification.

2.1 TEST FACILITY

The test facilities used to collect the test data in this report is at the location of No.3, Jinshagang 1st Road, Shixia, Dalang Town, Dongguan, Guangdong, China.

2.2 MEASUREMENT UNCERTAINTY

Where relevant, the following measurement uncertainty levels have been estimated for tests performed on the EUT as specified in CISPR 16-4-2, The BTL measurement uncertainty is less than the CISPR 16-4-2 U_{CISPR} requirement.

The reported uncertainty of measurement $y \pm U$, where expanded uncertainty U is based on a standard uncertainty multiplied by a coverage factor of $k=2$, providing a level of confidence of approximately **95%**.

A. Radiated emissions up to 1 GHz measurement:

Test Site	Method	Measurement Frequency Range	Ant. H / V	U, (dB)
DG-CB08 (10m)	CISPR	30MHz ~ 200MHz	V	4.66
		30MHz ~ 200MHz	H	4.64
		200MHz ~ 1,000MHz	V	4.88
		200MHz ~ 1,000MHz	H	4.86

B. Radiated emissions above 1 GHz measurement:

Test Site	Method	Measurement Frequency Range	U, (dB)
DG-CB08 (3m)	CISPR	1 ~ 6 GHz	4.26
		6 ~ 18 GHz	5.30

C. Conducted emissions AC mains power port measurement:

Test Site	Method	Measurement Frequency Range	U, (dB)
DG-C02	CISPR	150 kHz ~ 30MHz	2.32

D. Conducted disturbance at telecommunication port measurement:

Test Site	Method	Measurement Frequency Range	U, (dB)
DG-C02	CISPR	AAN 50...40dB	3.76
		AAN 65...50dB	3.76
		AAN 75...60dB	3.76
		Capacitive Voltage Probe	3.04
		RF Current Probe	2.58

E. Harmonic current emissions / Voltage changes, voltage fluctuations and flicker measurement:

Test Site	Method	Measurement Frequency Range	U, (dB)
DG-C01	EN 61000-3-2	Voltage	0.774
	EN 61000-3-3	Current	0.782

F. Immunity Measurement:

Test Site	Method	Measurement Frequency Range	U, (dB)
DG-SR02	EN 61000-4-2	Rise time t_r	14.6 %
		Peak current I_p	7.70 %
		Current at 30 ns	7.72 %
		Current at 60 ns	7.72 %
DG-CB05	EN 61000-4-3	80MHz~1GHz	2.175 dB
		On-ear acoustic & Acoustic measurements on loudspeakers	2.287 dB
		Electrical measurements	2.267 dB
		Measuring the demodulation on analogue wired network lines	2.267 dB
DG-SR05	EN 61000-4-4	Voltage rise time (t_r)	10.4 %
		Voltage peak value(V_P)	8.2 %
		Voltage pulse width(t_w)	6.0 %
DG-SR05	EN 61000-4-5	Voltage front time (T_{fv})	5.8 %
		Voltage peak value(V_P)	3.9 %
		Voltage duration(t_d)	0.6 %
DG-CB06	EN 61000-4-6	CDN	3.25 dB
		EM Clamp	4.410 dB
		On-ear acoustic & Acoustic measurements on loudspeakers	3.272 dB
		Electrical measurements	3.258 dB
		measuring the demodulation on analogue wired network lines	3.258 dB
DG-SR05	EN 61000-4-8	Magnetic Field Level	3.787 %
DG-SR05	EN 61000-4-11	voltage fall time (T_f)	2 %

Note: Unless specifically mentioned, the uncertainty of measurement has not been taken into account to declare the compliance or non-compliance to the specification.

3. GENERAL INFORMATION

3.1 GENERAL DESCRIPTION OF EUT

Equipment	IP Phone
Brand Name	Fanvil
Test Model	E6G
Series Model	F6, F6G
Model Difference	Only differ in model name.
Power Source	#1 Supplied form PoE. #2 DC Voltage supplied from AC/DC adapter. Model: F12DE1200100A Manufacturer: Shenzhen Sunlight Electronic Technology Co.,Ltd
Power Rating	#1 DC48V #2 I/P: AC100-240V 50/60Hz 0.5A max L.P.S O/P: 12V --- 1.0A
Connecting I/O port(s)	1* USB port 1* DC port 1* PC port 1* Internet port 1* Headphone port

Note:

1. For a more detailed features description, please refer to the manufacturer's specifications or the user's manual.

3.2 DESCRIPTION OF TEST MODES

To investigate the maximum EMI emission characteristics generates from EUT, the test system was pre-scanning tested base on the consideration of following EUT operation mode or test configuration mode which possible have effect on EMI emission level. Each of these EUT operation mode(s) or test configuration mode(s) mentioned above was evaluated respectively.

Pretest Mode	Description
Mode 1	Handfree
Mode 2	Handset
Mode 3	Headphone
Mode 4	PC Port 1Gbps
Mode 5	PC Port 100Mbps
Mode 6	PC Port 10Mbps
Mode 7	Internet Port 1Gbps
Mode 8	Internet Port 100Mbps
Mode 9	Internet Port 10Mbps

For Radiated Test	
Final Test Mode	Description
Mode 1	Handfree
Mode 2	Handset
Mode 3	Headphone

For Conducted Test	
Final Test Mode	Description
Mode 1	Handfree
Mode 2	Handset
Mode 3	Headphone

For ISN Test	
Final Test Mode	Description
Mode 4	PC Port 1Gbps
Mode 5	PC Port 100Mbps
Mode 6	PC Port 10Mbps
Mode 7	Internet Port 1Gbps
Mode 8	Internet Port 100Mbps
Mode 9	Internet Port 10Mbps

For Harmonics / Flickers Test	
Final Test Mode	Description
Mode 1	Handfree

For EMS Test	
Final Test Mode	Description
Mode 1	Handfree
Mode 2	Handset
Mode 3	Headphone

3.3 EUT OPERATING CONDITIONS

The EUT exercise program used during radiated and/or conducted emission measurement was designed to exercise the various system components in a manner similar to a typical use. The standard test signals and output signal as following:

Adapter:

1. EUT connected to notebook and IP Phone via RJ45 cable.
2. EUT connected to headphone via RJ11 cable.
3. EUT connected to adapter via DC cable.
4. The USB flash disk is plugged into the EUT.

PoE:

1. EUT connected to notebook and PoE switch via RJ45 cable.
2. EUT connected to headphone via RJ11 cable.
3. PoE switch connected to IP Phone via RJ45 cable.
4. PoE switch connected to adapter via DC cable.
5. The USB flash disk is plugged into the EUT.

3.4 BLOCK DIAGRAM SHOWING THE CONFIGURATION OF SYSTEM TESTED

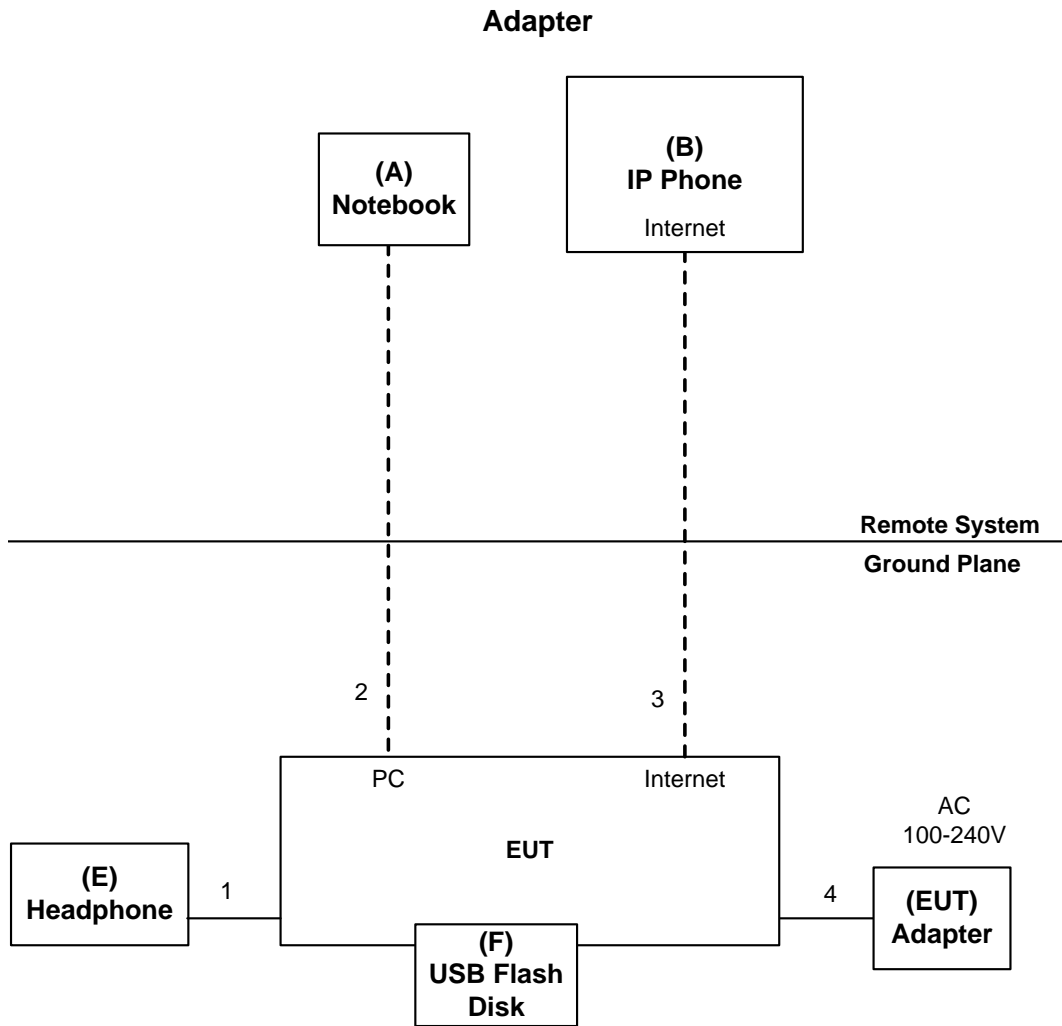

PoE

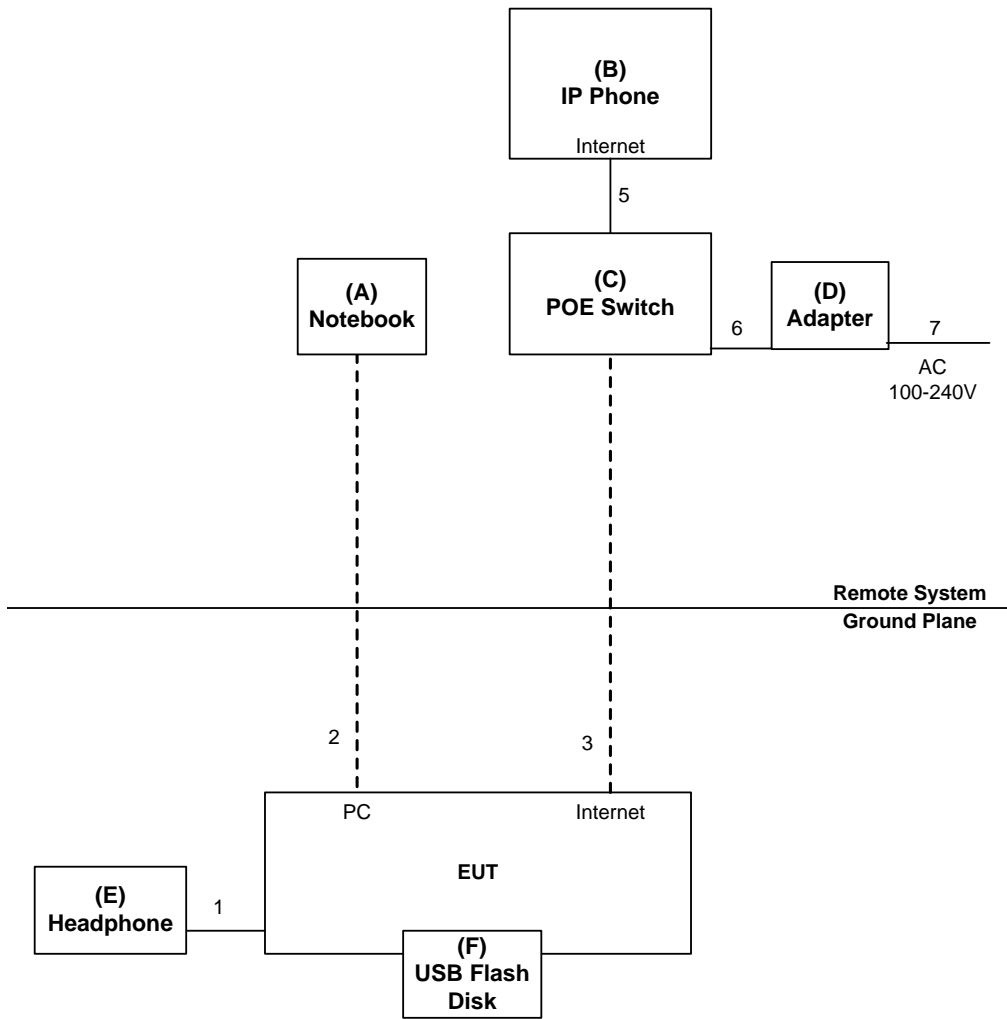

3.5 DESCRIPTION OF SUPPORT UNITS

The EUT has been tested as an independent unit together with other necessary accessories or support units. The following support units or accessories were used to form a representative test configuration during the tests.

Item	Equipment	Mfr/Brand	Model/Type No.	FCC ID	Series No.
A	Notebook	Lenovo	G40	DOC	YB09261386
B	IP Phone	Fanvil	X3SP	N/A	1000HF7371004260
C	PoE Switch	Fanvil	DGS-1008P/Dlink	N/A	N/A
D	Adapter	Leader	NU60-F4B0125-I1NN	N/A	N/A
E	Headphone	Fanvil	A310QD	N/A	N/A
F	USB Flash Disk	Kingston	DTI/1GB	DOC	39621564-014D517

Item	Shielded Type	Ferrite Core	Length	Note
1	NO	NO	1m	RJ11 Cable
2	NO	NO	10m	RJ45 Cable
3	NO	NO	10m	RJ45 Cable
4	NO	NO	1.5m	DC Cable
5	NO	NO	1.8m	RJ45 Cable
6	NO	YES	1.5m	DC Cable
7	NO	NO	1.8m	AC Cable

4. EMC EMISSION TEST

4.1 RADIATED EMISSION

4.1.1 LIMITS

Class A equipment up to 1000MHz

Table clause	Frequency range MHz	Measurement			Class A limits dB(μ V/m)
		Facility (see Table A.1)	Distance m	Detector type/ bandwidth	
A2.1	30-230	OATS/SAC	10	Quasi peak / 120 kHz	40
	230-1000				47
A2.2	30-230	OATS/SAC	3		50
	230-1000				57
A2.3	30-230	FAR	10	Quasi peak / 120 kHz	42 to 35
	230-1000				42
A2.4	30-230	FAR	3		52 to 45
	230-1000				52

Apply only A2.1 or A2.2 or A2.3 or A2.4 across the entire frequency range.

Class A equipment above 1000MHz

Table clause	Frequency range MHz	Measurement			Class A limits dB(μ V/m)
		Facility (see Table A.1)	Distance m	Detector type/bandwidth	
A3.1	1000-3000	FSOATS	3	Average / 1 MHz	56
	3000-6000				60
A3.2	1000-3000			Peak / 1 MHz	76
	3000-6000				80

Apply A3.1 and A3.2 across the frequency range from 1 000 MHz to the highest required frequency of measurement derived from Table 1.

Class B equipment up to 1000MHz

Table clause	Frequency range MHz	Measurement			Class B limits dB(μV/m)
		Facility (see Table A.1)	Distance m	Detector type/ bandwidth	
A4.1	30-230	OATS/SAC	10	Quasi peak / 120 kHz	30
	230-1000				37
A4.2	30-230	OATS/SAC	3		40
	230-1000				47
A4.3	30-230	FAR	10	32 to 25	
	230-1000			32	
A4.4	30-230	FAR	3	42 to 35	
	230-1000			42	

Apply only table clause A4.1 or A4.2 or A4.3 or A4.4 across the entire frequency range. These requirements are not applicable to the local oscillator and harmonics frequencies of equipment covered by Table A.6.

Class B equipment above 1000MHz

Table clause	Frequency range MHz	Measurement			Class B limits dB(μV/m)
		Facility (see Table A.1)	Distance m	Detector type/ bandwidth	
A5.1	1000-3000	FSOATS	3	Average / 1 MHz	50
	3000-6000				54
A5.2	1000-3000			Peak / 1 MHz	70
	3000-6000				74

Apply A5.1 and A5.2 across the frequency range from 1 000 MHz to the highest required frequency of measurement derived from Table 1.

Notes:

- (1) The limit for radiated test was performed according to as following: EN 55032
- (2) The tighter limit applies at the band edges.
- (3) Emission level (dBuV/m)=20log Emission level (uV/m).
- (4) The test result calculated as following:
 Measurement Value = Reading Level + Correct Factor
 Correct Factor = Antenna Factor + Cable Loss - Amplifier Gain(if use)
 Margin Level = Measurement Value - Limit Value

Required highest frequency for radiated measurement

Highest internal frequency (F_x) MHz	Highest measured frequency MHz
$F_x \leq 108$	1000
$108 < F_x \leq 500$	2000
$500 < F_x \leq 1000$	5000
$F_x > 1000$	5 th up to a maximum 6 GHz,

Note for FM and TV broadcast receiver, F_x is determined from the highest frequency generated or used excluding the local oscillator and tuned frequencies.

4.1.2 MEASUREMENT INSTRUMENTS LIST

Up to 1GHz:

Item	Kind of Equipment	Manufacturer	Type No.	Serial No.	Calibrated until
1	Pre-Amplifier	Mini-Circuits	EMC 9135	980284	Mar. 26, 2018
2	Pre-Amplifier	Mini-Circuits	EMC 9135	980283	Mar. 26, 2018
3	Trilog-Broadband Antenna	Schwarzbeck	VULB9168	586	Mar. 26, 2018
4	Trilog-Broadband Antenna	Schwarzbeck	VULB9168	587	Mar. 26, 2018
5	Cable	emci	LMR-400(5 m+11m+15 m)	N/A	Dec. 27, 2017
6	Cable	emci	LMR-400(5 m+8m+15 m)	N/A	Dec. 27, 2017
7	Measurement Software	Farad	EZ-EMC Ver.BTL-2A NT-1	N/A	N/A
8	Multi-Device Controller	ETS-Lindgren	2090	N/A	N/A
9	Attenuator	N/A	SA18N-06	6dB	Apr. 14, 2018
10	Attenuator	N/A	SA18N-06	6dB	Apr. 14, 2018
11	Receiver	Keysight	N9038A	MY54450004	Aug. 15, 2018
12	MXE EMI Receiver	Agilent	N9038A	MY53220133	Jun. 20, 2018

Remark: "N/A" denotes no model name, no serial no. or no calibration specified.
All calibration period of equipment list is one year.

Above 1GHz:

Item	Kind of Equipment	Manufacturer	Type No.	Serial No.	Calibrated until
1	Measurement Software	Farad	EZ-EMC Ver.BTL-2AN T-1	N/A	N/A
2	Cable	emci	SUCOFLEX_ 15m_5m(0.01 GHz – 26.5GHz)	N/A	Dec. 27, 2017
3	Multi-Device Controller	ETS-Lindgren	2090	N/A	N/A
4	Controller	MF	MF-7802	MF780208159	N/A
5	Horn Antenna	EMCO	3115	9605-4803	Mar. 26, 2018
6	Amplifier	Agilent	8449B	3008A02584	Aug. 20, 2018
7	MXE EMI Receiver	Agilent	N9038A	MY53220133	Jun. 20, 2018

Remark: “N/A” denotes no model name, no serial no. or no calibration specified.

All calibration period of equipment list is one year.

4.1.3 TEST PROCEDURE

- a. The measuring distance of 10 m shall be used for measurements. The EUT was placed on the top of a rotating table 0.8 meter above the ground at a 10 meter semi-anechoic chamber. The table was rotated 360 degrees to determine the position of the highest radiation.(below 1GHz).
- b. The measuring distance of 3 m shall be used for measurements. The EUT was placed on the top of a rotating table 0.8 meter above the ground at a 10 meter semi-anechoic chamber. The table was rotated 360 degrees to determine the position of the highest radiation.(above 1GHz)
- c. The height of the equipment or of the substitution antenna shall be 0.8 m, the height of the test antenna shall vary between 1 m to 4 m. Both horizontal and vertical polarizations of the antenna are set to make the measurement.
- d. The initial step in collecting radiated emission data is a receiver peak detector mode pre-scanning the measurement frequency range. Significant peaks are then marked and then Quasi Peak detector mode re-measured.
- e. All readings are Peak unless otherwise stated QP in column of Note. Peak denotes that the Peak reading compliance with the QP Limits and then QP Mode measurement didn't perform. (below 1GHz)
- f. All readings are Peak Mode value unless otherwise stated AVG in column of Note. If the Peak Mode Measured value compliance with the Peak Limits and lower than AVG Limits, the EUT shall be deemed to meet both Peak & AVG Limits and then only Peak Mode was measured, but AVG Mode didn't perform. (above 1GHz)
- g. For the actual test configuration, please refer to the related Item - Block Diagram of system tested (please refer to 3.3).

4.1.4 DEVIATION FROM TEST STANDARD

No deviation

4.1.5 TEST SETUP

UP TO 1 GHZ

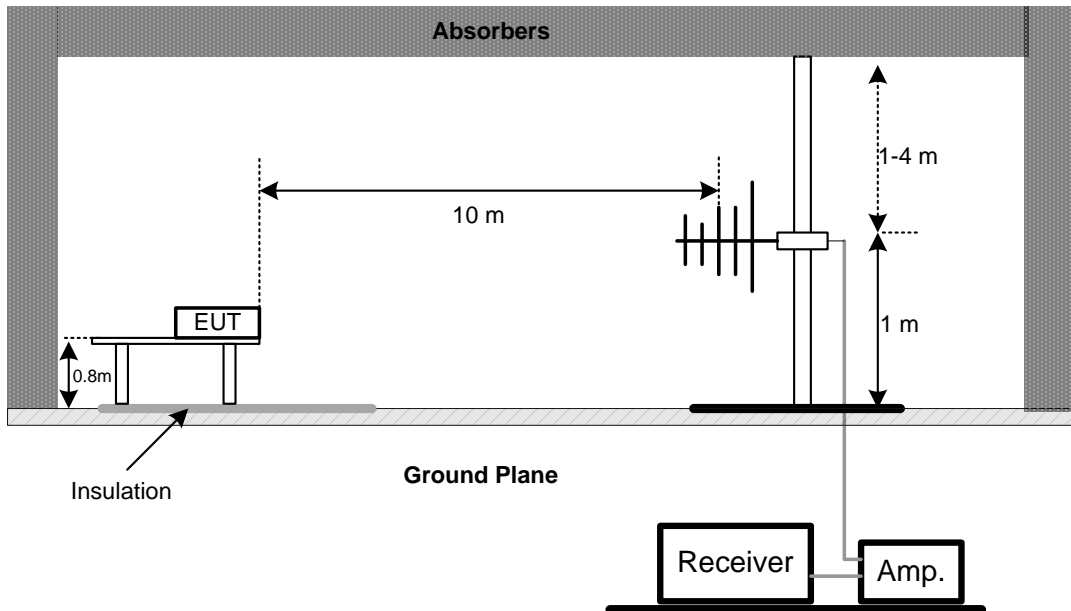

Note: The antenna can be moved between 1 to 4 meters above the ground.

ABOVE 1 GHZ

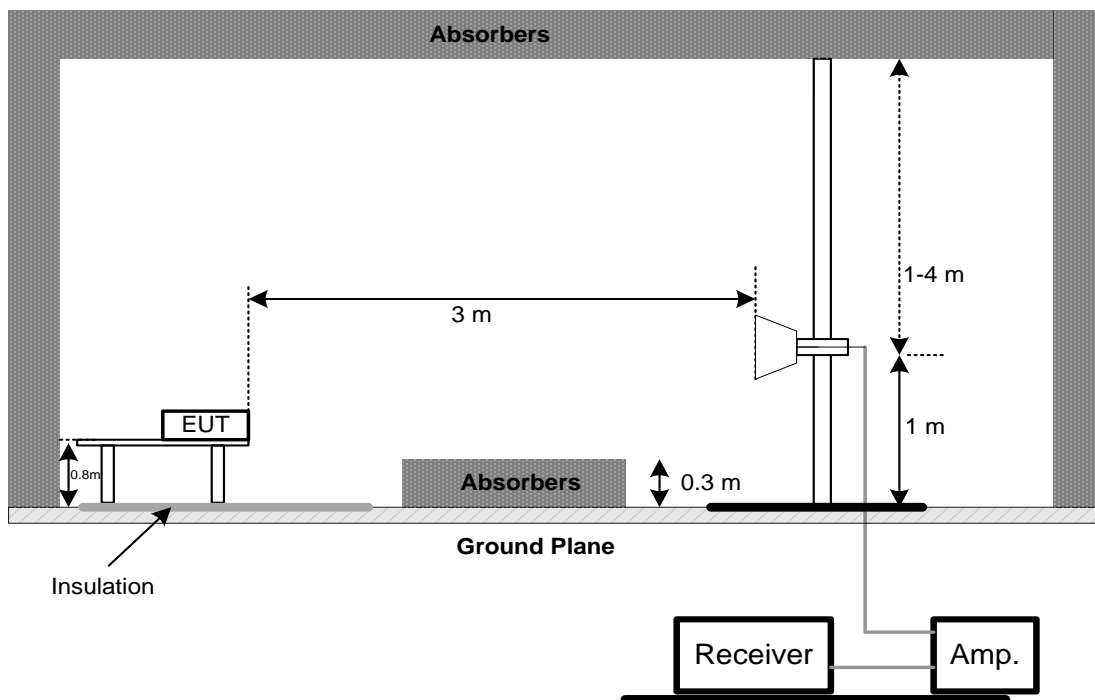

4.1.6 MEASUREMENT DISTANCE

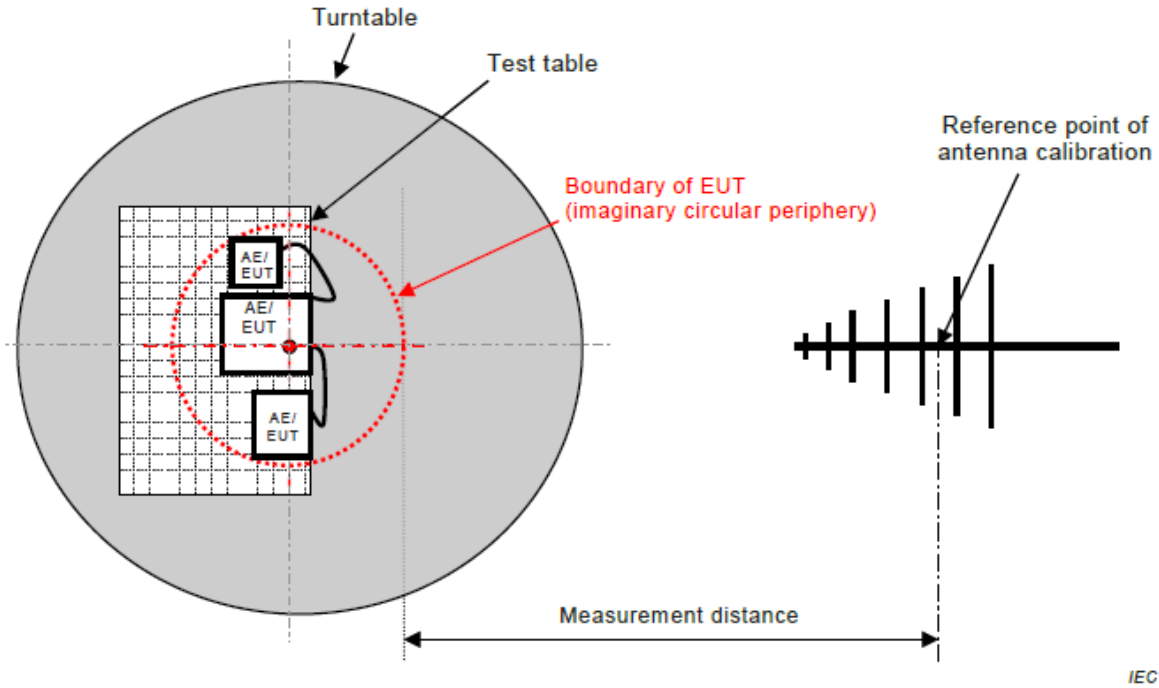

Figure C.1 – Measurement distance

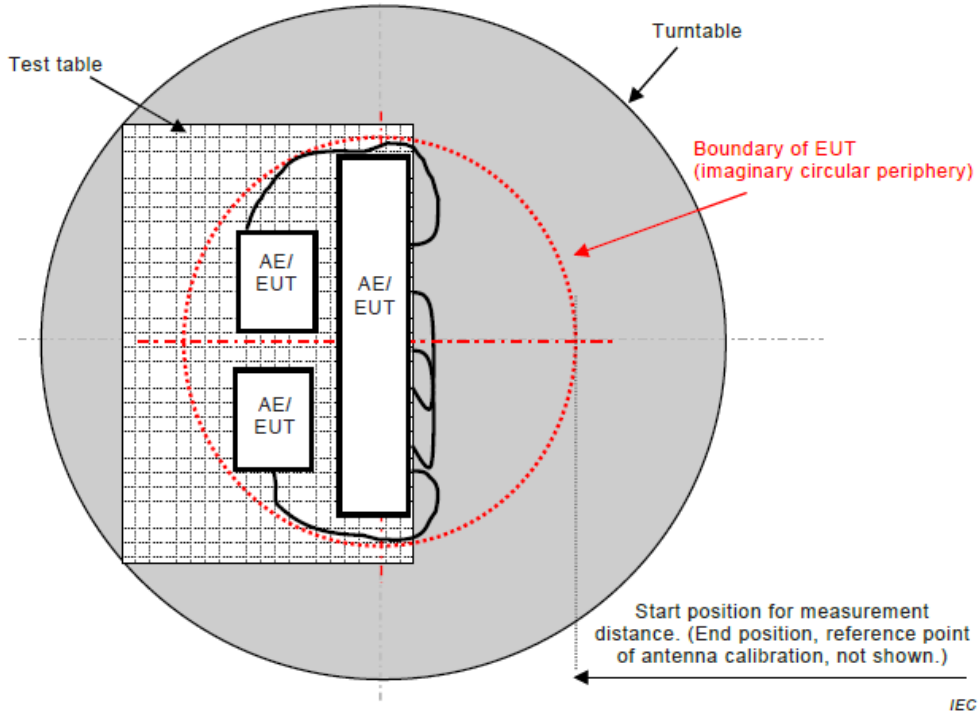
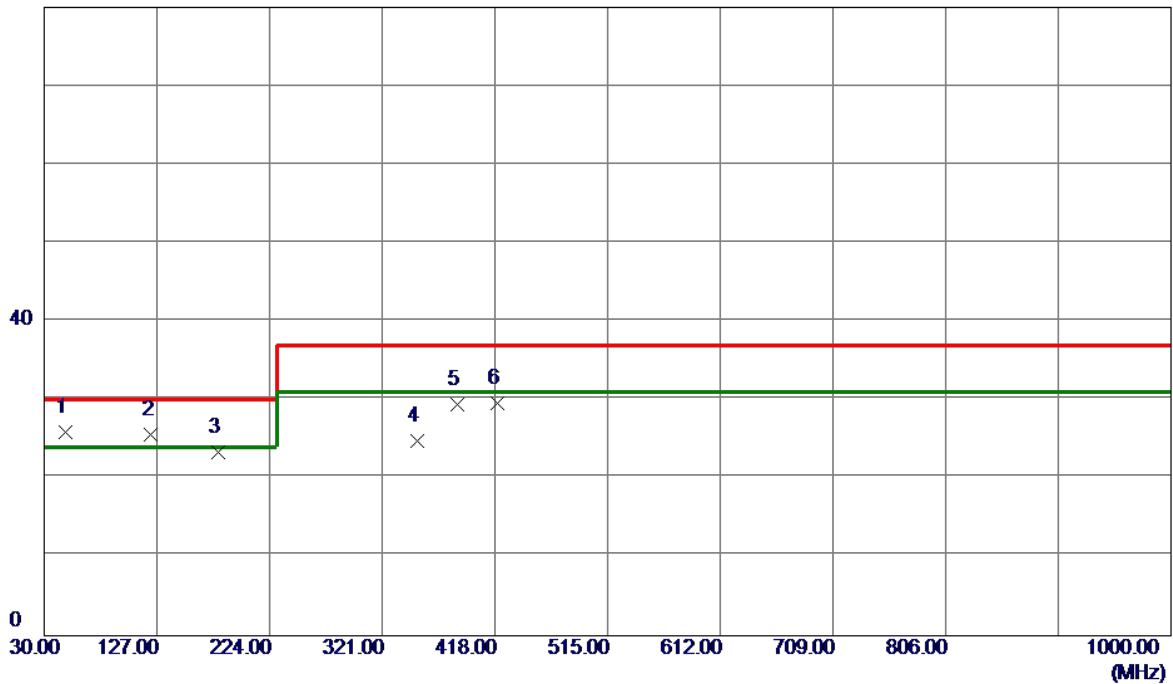

Figure C.2 – Boundary of EUT, Local AE and associated cabling

4.1.7 TEST RESULTS (UP TO 1 GHZ)

EUT	IP Phone	Model Name	E6G
Temperature	25°C	Relative Humidity	60%
Test Voltage	DC 48V	Polarization	Vertical
Test Mode	Handfree		
Note	PoE		
Test Engineer	Jason Yang		

80 dBuV/m



No.	Freq. MHz	Reading Level dBuV/m	Correct Factor dB	Measure ment dBuV/m	Limit dBuV/m	Margin dB	Detector
1 *	47.9450	48.17	-22.30	25.87	30.00	-4.13	QP
2	122.1500	49.20	-23.57	25.63	30.00	-4.37	QP
3	179.8650	45.88	-22.55	23.33	30.00	-6.67	QP
4	351.5550	43.52	-18.72	24.80	37.00	-12.20	QP
5	385.9900	47.10	-17.69	29.41	37.00	-7.59	QP
6	419.9400	46.21	-16.56	29.65	37.00	-7.35	QP

EUT	IP Phone	Model Name	E6G
Temperature	25°C	Relative Humidity	60%
Test Voltage	DC 48V	Polarization	Horizontal
Test Mode	Handfree		
Note	PoE		
Test Engineer	Jason Yang		

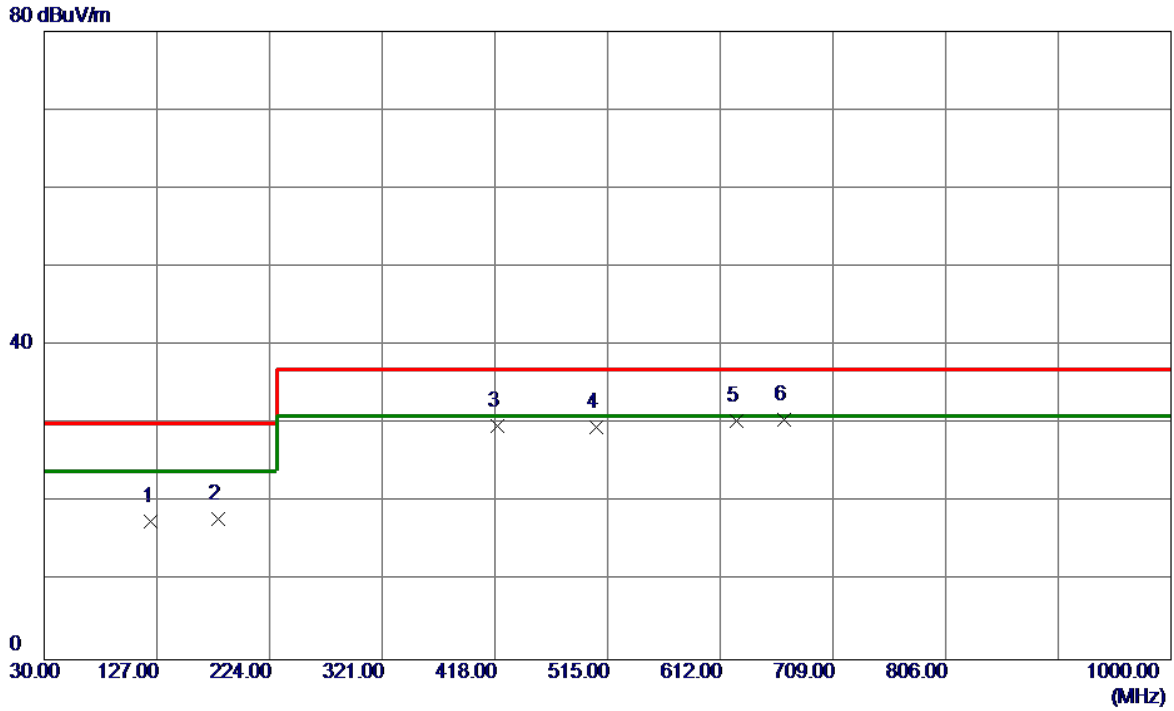

No.	Freq. MHz	Reading Level dBuV/m	Correct Factor dB	Measure ment dBuV/m	Limit dBuV/m	Margin dB	Detector
1	122.1500	40.82	-23.24	17.58	30.00	-12.42	QP
2	179.8650	40.15	-22.26	17.89	30.00	-12.11	QP
3	419.9400	46.05	-16.24	29.81	37.00	-7.19	QP
4	505.7850	43.94	-14.35	29.59	37.00	-7.41	QP
5	625.5800	42.09	-11.68	30.41	37.00	-6.59	QP
6 *	666.8050	41.76	-11.14	30.62	37.00	-6.38	QP

EUT	IP Phone	Model Name	E6G
Temperature	25°C	Relative Humidity	60%
Test Voltage	AC 230V/50Hz	Polarization	Vertical
Test Mode	Handfree		
Note	Adapter		
Test Engineer	Jason Yang		

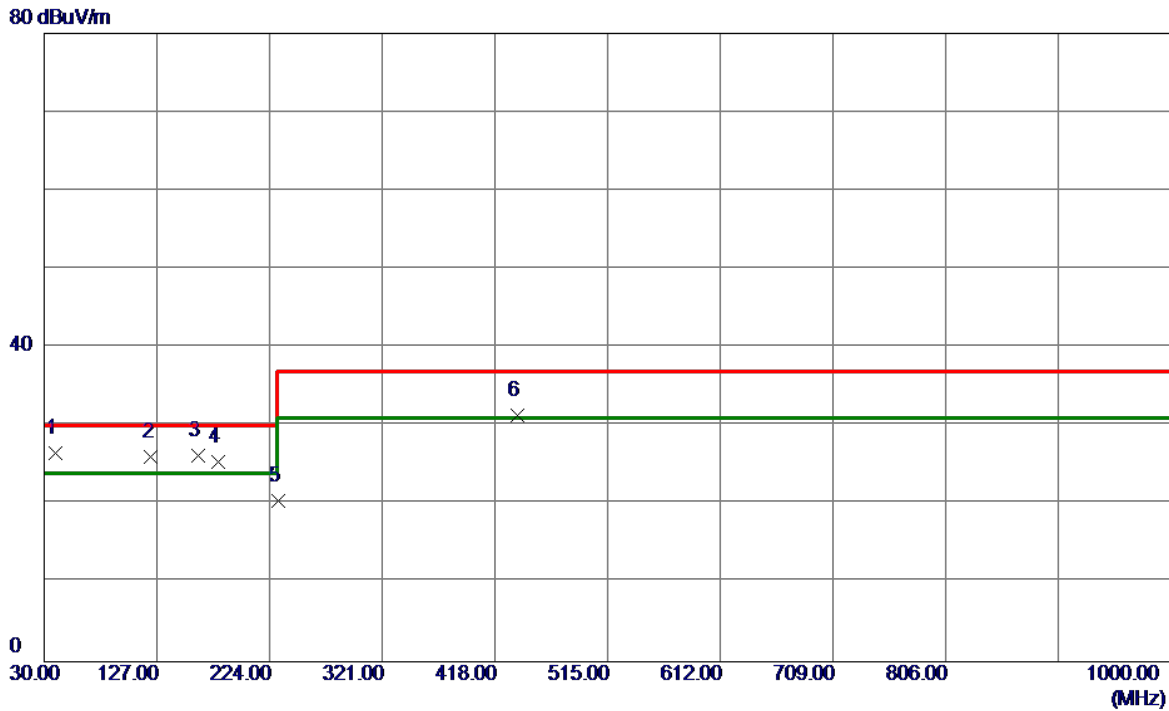

No.	Freq. MHz	Reading Level dBuV/m	Correct Factor dB	Measure ment dBuV/m	Limit dBuV/m	Margin dB	Detector
1 *	39.7000	49.79	-23.27	26.52	30.00	-3.48	QP
2	122.1500	49.59	-23.57	26.02	30.00	-3.98	QP
3	162.8900	47.49	-21.27	26.22	30.00	-3.78	QP
4	179.8650	47.97	-22.55	25.42	30.00	-4.58	QP
5	231.2750	43.79	-23.37	20.42	37.00	-16.58	QP
6	437.4000	47.37	-15.94	31.43	37.00	-5.57	QP

EUT	IP Phone	Model Name	E6G
Temperature	25°C	Relative Humidity	60%
Test Voltage	AC 230V/50Hz	Polarization	Horizontal
Test Mode	Handfree		
Note	Adapter		
Test Engineer	Jason Yang		

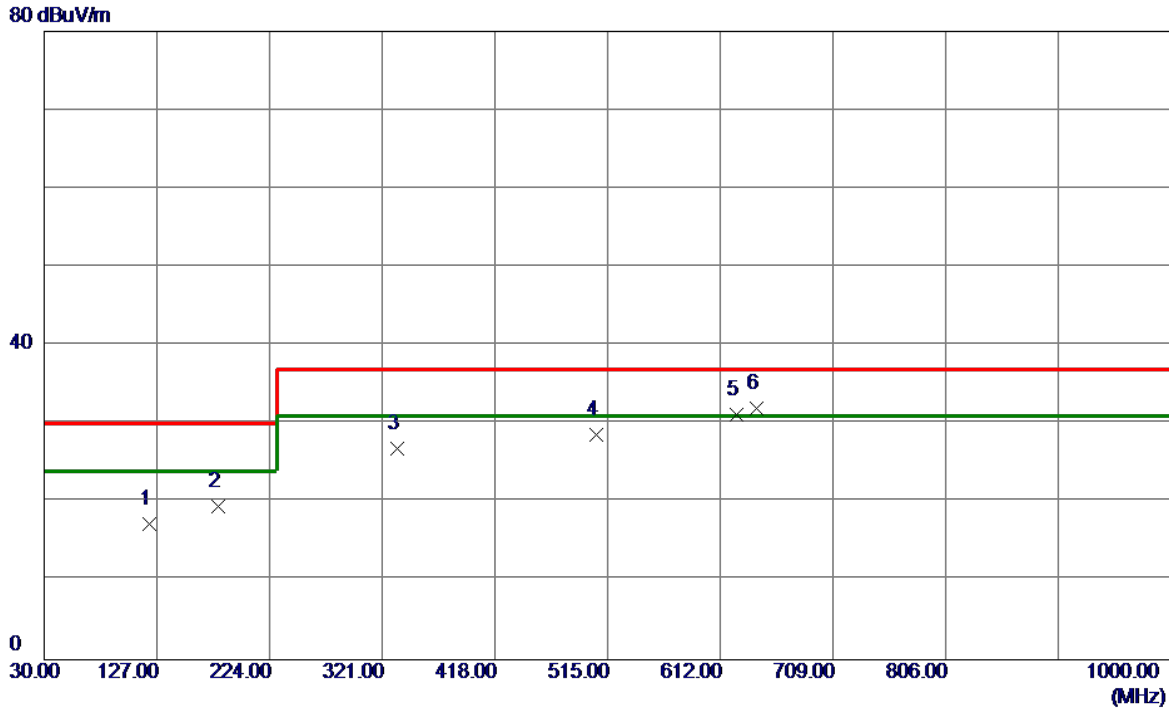

No.	Freq. MHz	Reading Level dBuV/m	Correct Factor dB	Measure ment dBuV/m	Limit dBuV/m	Margin dB	Detector
1	120.2100	40.77	-23.42	17.35	30.00	-12.65	QP
2	179.8650	41.71	-22.26	19.45	30.00	-10.55	QP
3	334.0950	45.59	-18.65	26.94	37.00	-10.06	QP
4	505.7850	43.06	-14.35	28.71	37.00	-8.29	QP
5	625.5800	42.90	-11.68	31.22	37.00	-5.78	QP
6 *	643.0400	43.38	-11.38	32.00	37.00	-5.00	QP

EUT	IP Phone	Model Name	E6G
Temperature	25°C	Relative Humidity	60%
Test Voltage	DC 48V	Polarization	Vertical
Test Mode	Handset		
Note	PoE		
Test Engineer	Jason Yang		

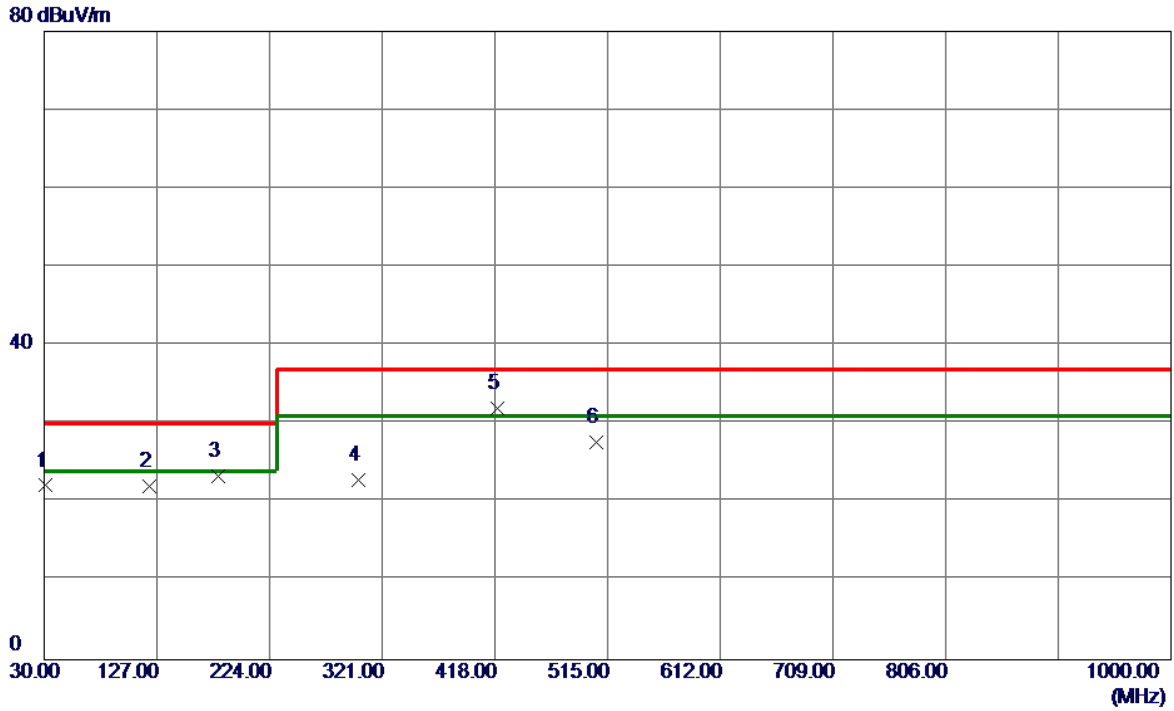

No.	Freq. MHz	Reading Level dBuV/m	Correct Factor dB	Measure ment dBuV/m	Limit dBuV/m	Margin dB	Detector
1	31.4550	46.14	-23.98	22.16	30.00	-7.84	QP
2	120.2100	45.85	-23.75	22.10	30.00	-7.90	QP
3	179.8650	45.97	-22.55	23.42	30.00	-6.58	QP
4	300.1450	42.78	-19.87	22.91	37.00	-14.09	QP
5 *	419.9400	48.59	-16.56	32.03	37.00	-4.97	QP
6	505.7850	42.14	-14.53	27.61	37.00	-9.39	QP

EUT	IP Phone	Model Name	E6G
Temperature	25°C	Relative Humidity	60%
Test Voltage	DC 48V	Polarization	Horizontal
Test Mode	Handset		
Note	PoE		
Test Engineer	Jason Yang		

80 dBuV/m

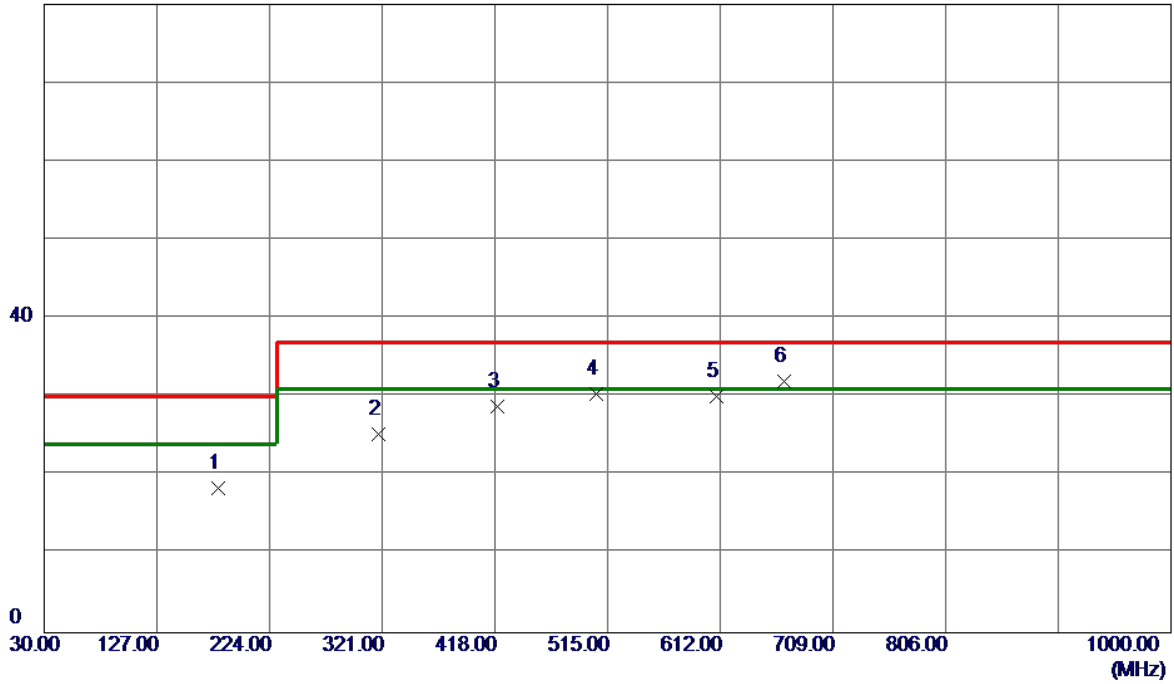

No.	Freq. MHz	Reading Level dBuV/m	Correct Factor dB	Measure ment dBuV/m	Limit dBuV/m	Margin dB	Detector
1	179.5295	40.69	-22.23	18.46	30.00	-11.54	QP
2	317.4074	44.39	-19.05	25.34	37.00	-11.66	QP
3	420.3303	45.05	-16.23	28.82	37.00	-8.18	QP
4	505.7757	44.71	-14.35	30.36	37.00	-6.64	QP
5	608.6986	42.00	-11.97	30.03	37.00	-6.97	QP
6 *	666.9570	43.11	-11.13	31.98	37.00	-5.02	QP

EUT	IP Phone	Model Name	E6G
Temperature	25°C	Relative Humidity	60%
Test Voltage	AC 230V/50Hz	Polarization	Vertical
Test Mode	Handset		
Note	Adapter		
Test Engineer	Jason Yang		

80 dBuV/m

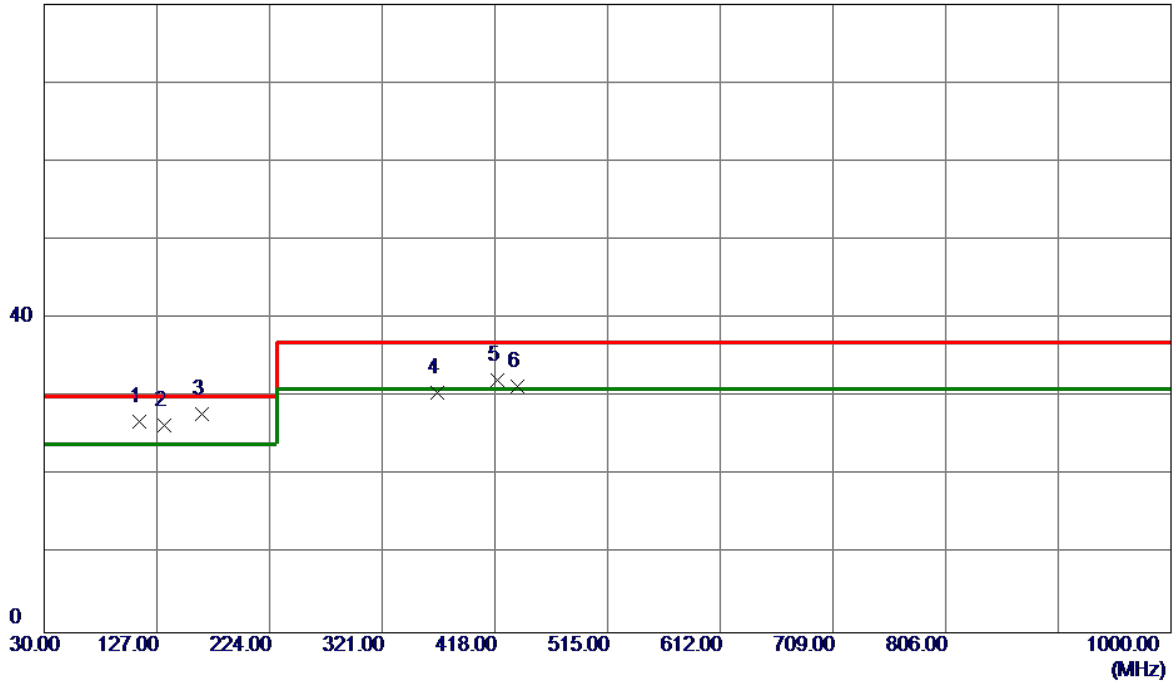

No.	Freq. MHz	Reading Level dBuV/m	Correct Factor dB	Measure ment dBuV/m	Limit dBuV/m	Margin dB	Detector
1	111.4800	51.42	-24.49	26.93	30.00	-3.07	QP
2	133.7899	48.91	-22.46	26.45	30.00	-3.55	QP
3 *	165.3150	49.32	-21.41	27.91	30.00	-2.09	QP
4	368.5300	48.84	-18.21	30.63	37.00	-6.37	QP
5	419.9400	48.74	-16.56	32.18	37.00	-4.82	QP
6	437.4000	47.33	-15.94	31.39	37.00	-5.61	QP

EUT	IP Phone	Model Name	E6G
Temperature	25°C	Relative Humidity	60%
Test Voltage	AC 230V/50Hz	Polarization	Horizontal
Test Mode	Handset		
Note	Adapter		
Test Engineer	Jason Yang		

80 dBuV/m

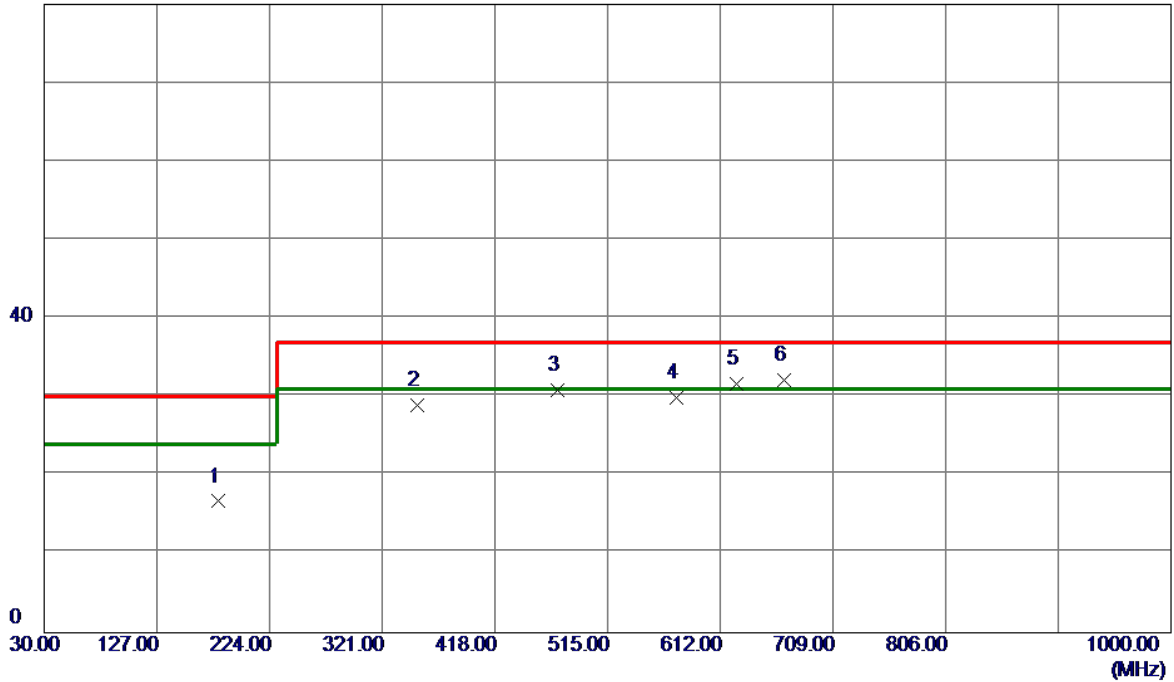

No.	Freq. MHz	Reading Level dBuV/m	Correct Factor dB	Measure ment dBuV/m	Limit dBuV/m	Margin dB	Detector
1	179.8650	38.98	-22.26	16.72	30.00	-13.28	QP
2	351.5550	47.26	-18.23	29.03	37.00	-7.97	QP
3	471.3500	45.79	-14.90	30.89	37.00	-6.11	QP
4	574.1700	42.80	-12.88	29.92	37.00	-7.08	QP
5	625.5800	43.37	-11.68	31.69	37.00	-5.31	QP
6 *	666.8050	43.25	-11.14	32.11	37.00	-4.89	QP

EUT	IP Phone	Model Name	E6G
Temperature	25°C	Relative Humidity	60%
Test Voltage	AC 110V/60Hz	Polarization	Vertical
Test Mode	Handset		
Note	Adapter		
Test Engineer	Jason Yang		

80 dBuV/m

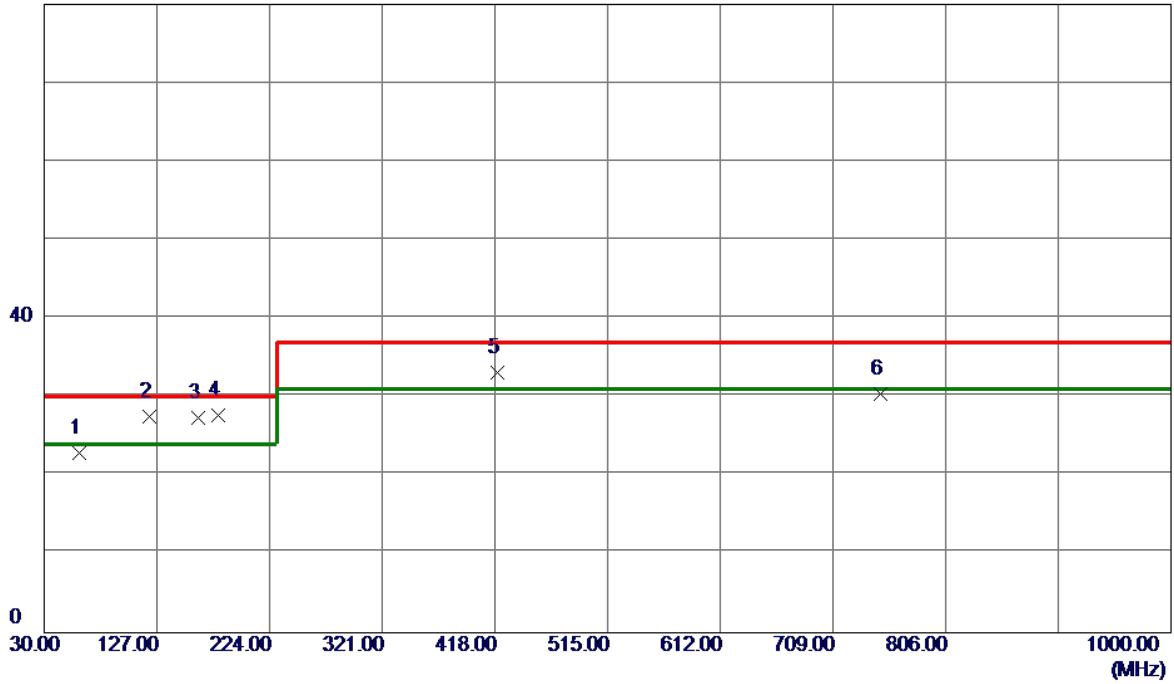

No.	Freq. MHz	Reading Level dBuV/m	Correct Factor dB	Measure ment dBuV/m	Limit dBuV/m	Margin dB	Detector
1	60.0700	45.37	-22.55	22.82	30.00	-7.18	QP
2	120.2100	51.34	-23.75	27.59	30.00	-2.41	QP
3	162.8900	48.70	-21.27	27.43	30.00	-2.57	QP
4 *	179.8650	50.19	-22.55	27.64	30.00	-2.36	QP
5	419.9400	49.69	-16.56	33.13	37.00	-3.87	QP
6	750.2250	40.56	-10.09	30.47	37.00	-6.53	QP

EUT	IP Phone	Model Name	E6G
Temperature	25°C	Relative Humidity	60%
Test Voltage	AC 110V/60Hz	Polarization	Horizontal
Test Mode	Handset		
Note	Adapter		
Test Engineer	Jason Yang		

80 dBuV/m

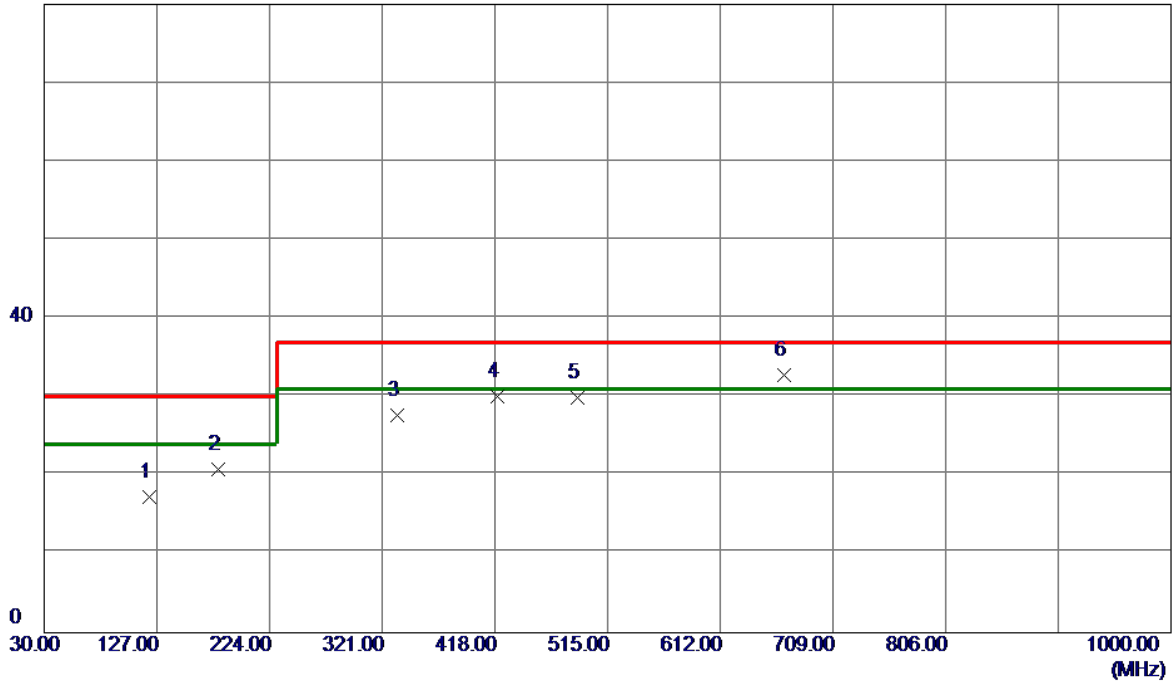

No.	Freq. MHz	Reading Level dBuV/m	Correct Factor dB	Measure ment dBuV/m	Limit dBuV/m	Margin dB	Detector
1	120.2100	40.65	-23.42	17.23	30.00	-12.77	QP
2	179.8650	43.04	-22.26	20.78	30.00	-9.22	QP
3	334.0950	46.34	-18.65	27.69	37.00	-9.31	QP
4	419.9400	46.27	-16.24	30.03	37.00	-6.97	QP
5	488.8100	44.48	-14.63	29.85	37.00	-7.15	QP
6 *	666.8050	44.00	-11.14	32.86	37.00	-4.14	QP

EUT	IP Phone	Model Name	E6G
Temperature	25°C	Relative Humidity	60%
Test Voltage	DC 48V	Polarization	Vertical
Test Mode	Headphone		
Note	PoE		
Test Engineer	Jason Yang		

80 dBuV/m

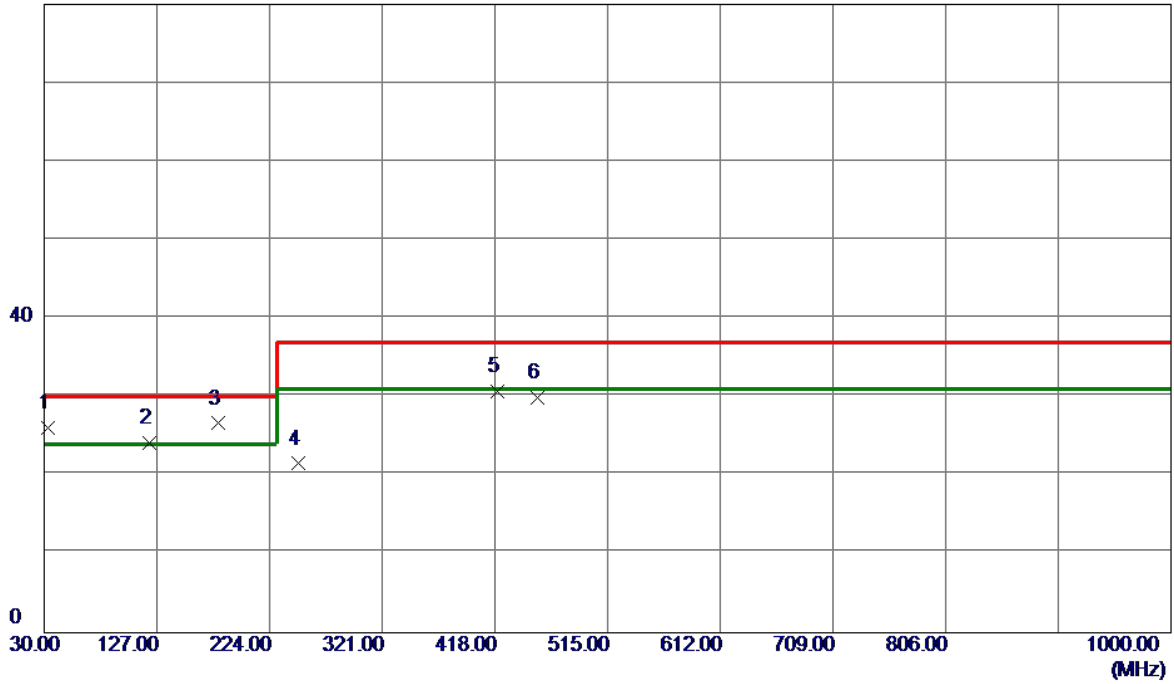

No.	Freq. MHz	Reading Level dBuV/m	Correct Factor dB	Measure ment dBuV/m	Limit dBuV/m	Margin dB	Detector
1	33.3950	49.90	-23.85	26.05	30.00	-3.95	QP
2	120.2100	47.93	-23.75	24.18	30.00	-5.82	QP
3 *	179.8650	49.19	-22.55	26.64	30.00	-3.36	QP
4	248.7350	43.38	-21.86	21.52	37.00	-15.48	QP
5	419.9400	47.32	-16.56	30.76	37.00	-6.24	QP
6	454.3750	45.27	-15.41	29.86	37.00	-7.14	QP

EUT	IP Phone	Model Name	E6G
Temperature	25°C	Relative Humidity	60%
Test Voltage	DC 48V	Polarization	Horizontal
Test Mode	Headphone		
Note	PoE		
Test Engineer	Jason Yang		

80 dBuV/m

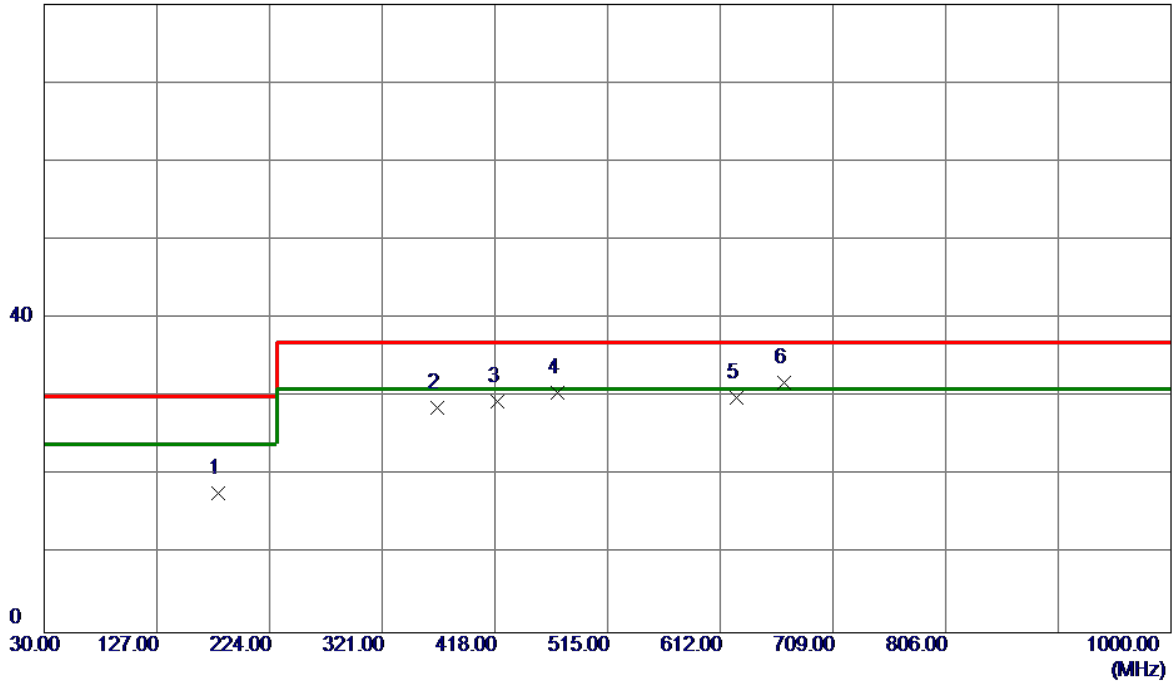

No.	Freq. MHz	Reading Level dBuV/m	Correct Factor dB	Measure ment dBuV/m	Limit dBuV/m	Margin dB	Detector
1	179.8650	40.09	-22.26	17.83	30.00	-12.17	QP
2	368.5300	46.35	-17.76	28.59	37.00	-8.41	QP
3	419.9400	45.66	-16.24	29.42	37.00	-7.58	QP
4	471.3500	45.52	-14.90	30.62	37.00	-6.38	QP
5	625.5800	41.67	-11.68	29.99	37.00	-7.01	QP
6 *	666.8050	43.03	-11.14	31.89	37.00	-5.11	QP

EUT	IP Phone	Model Name	E6G
Temperature	25°C	Relative Humidity	60%
Test Voltage	AC 230V/50Hz	Polarization	Vertical
Test Mode	Headphone		
Note	Adapter		
Test Engineer	Jason Yang		

80 dBuV/m

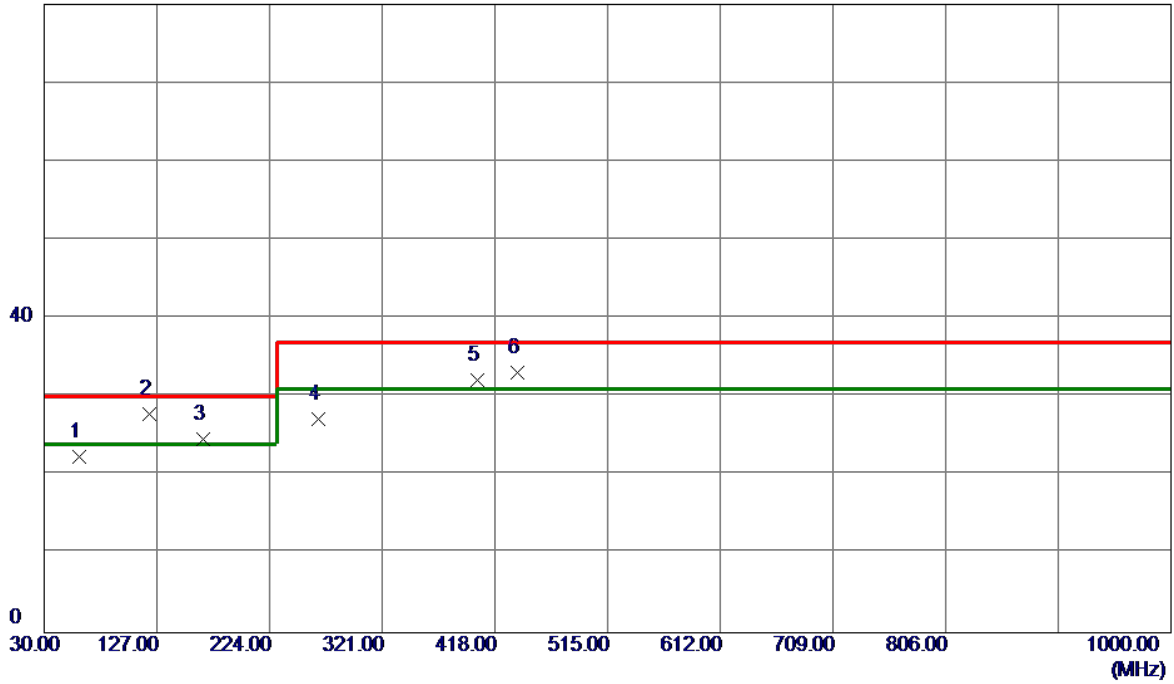

No.	Freq. MHz	Reading Level dBuV/m	Correct Factor dB	Measure ment dBuV/m	Limit dBuV/m	Margin dB	Detector
1	60.0700	45.02	-22.55	22.47	30.00	-7.53	QP
2 *	120.2100	51.61	-23.75	27.86	30.00	-2.14	QP
3	167.2550	46.20	-21.52	24.68	30.00	-5.32	QP
4	265.7100	48.35	-21.11	27.24	37.00	-9.76	QP
5	402.9650	49.32	-17.16	32.16	37.00	-4.84	QP
6	437.4000	49.02	-15.94	33.08	37.00	-3.92	QP

EUT	IP Phone	Model Name	E6G
Temperature	25°C	Relative Humidity	60%
Test Voltage	AC 230V/50Hz	Polarization	Horizontal
Test Mode	Headphone		
Note	Adapter		
Test Engineer	Jason Yang		

80 dBuV/m

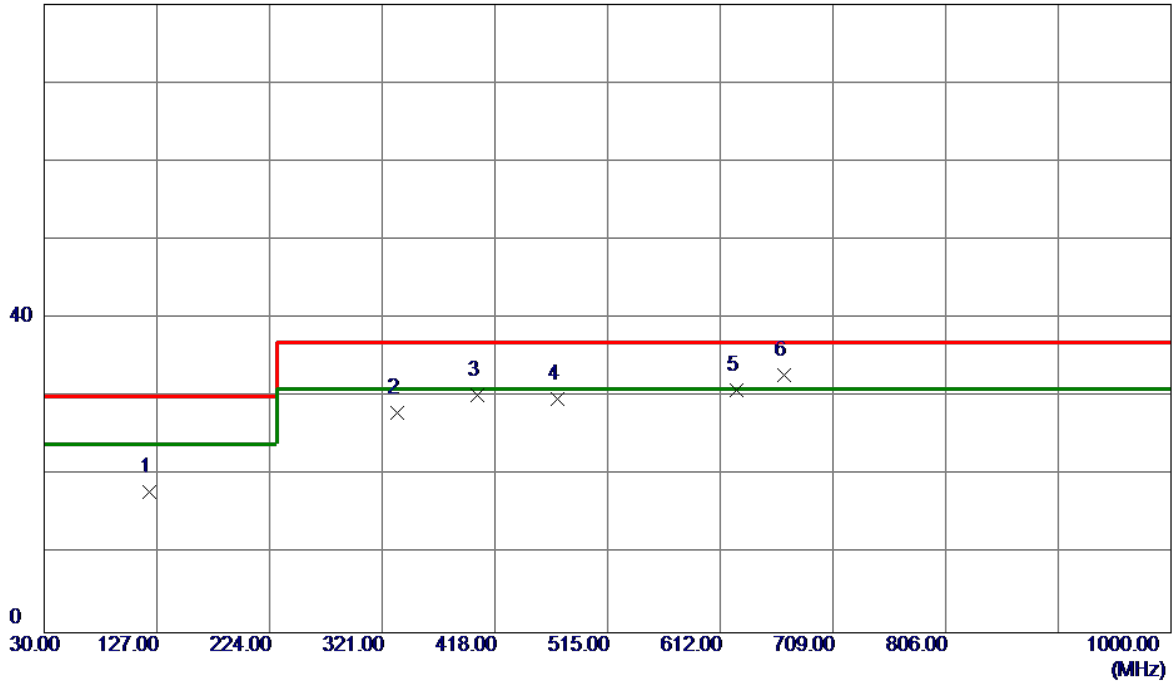

No.	Freq. MHz	Reading Level dBuV/m	Correct Factor dB	Measure ment dBuV/m	Limit dBuV/m	Margin dB	Detector
1	120.2100	41.39	-23.42	17.97	30.00	-12.03	QP
2	334.0950	46.64	-18.65	27.99	37.00	-9.01	QP
3	402.9650	46.99	-16.80	30.19	37.00	-6.81	QP
4	471.3500	44.73	-14.90	29.83	37.00	-7.17	QP
5	625.5800	42.53	-11.68	30.85	37.00	-6.15	QP
6 *	666.8050	43.98	-11.14	32.84	37.00	-4.16	QP

4.1.8 TEST RESULTS (ABOVE 1 GHZ)

EUT	IP Phone	Model Name	E6G
Temperature	25°C	Relative Humidity	60%
Test Voltage	DC 48V	Polarization	Vertical
Test Mode	Handfree		
Note	PoE		
Test Engineer	Jason Yang		

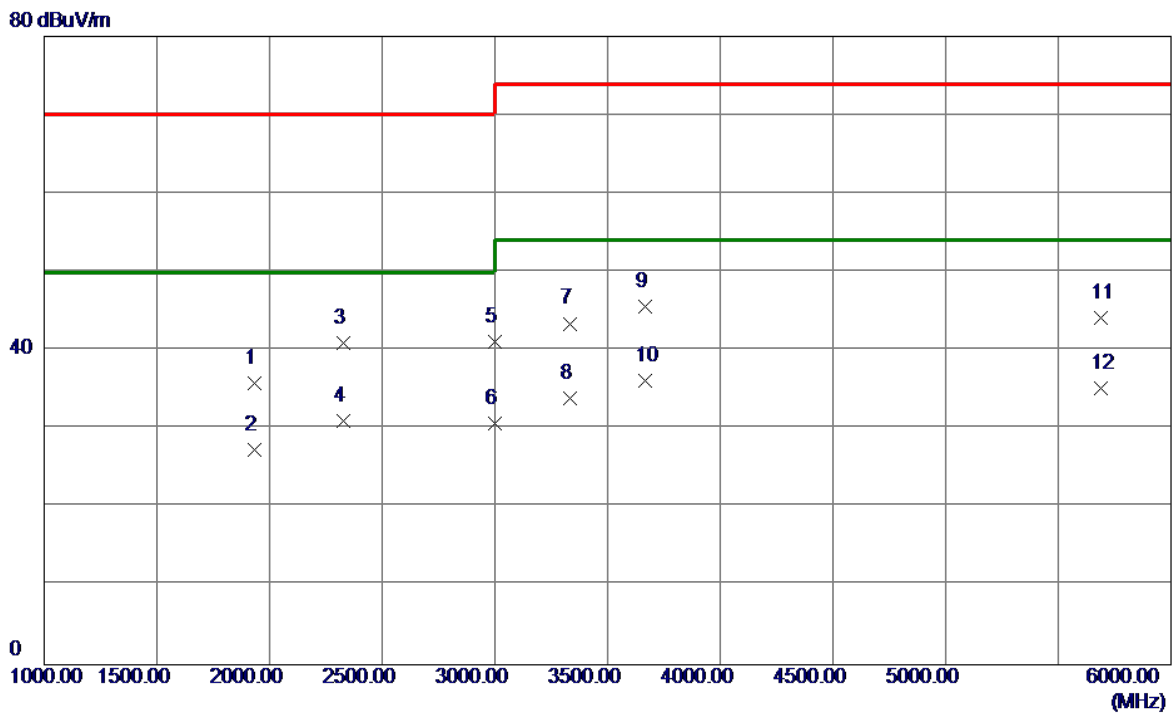

No.	Freq. MHz	Reading Level dBuV/m	Correct Factor dB	Measure ment dBuV/m	Limit dBuV/m	Margin dB	Detector
1	1935.0000	39.02	-3.22	35.80	70.00	-34.20	Peak
2	1935.0000	30.51	-3.22	27.29	50.00	-22.71	AVG
3	2330.0000	42.23	-1.31	40.92	70.00	-29.08	Peak
4	2330.0000	32.30	-1.31	30.99	50.00	-19.01	AVG
5	3000.0000	38.69	2.42	41.11	70.00	-28.89	Peak
6	3000.0000	28.30	2.42	30.72	50.00	-19.28	AVG
7	3335.0000	40.58	2.86	43.44	74.00	-30.56	Peak
8	3335.0000	31.10	2.86	33.96	54.00	-20.04	AVG
9	3665.0000	42.54	3.05	45.59	74.00	-28.41	Peak
10 *	3665.0000	33.11	3.05	36.16	54.00	-17.84	AVG
11	5690.0000	35.25	8.84	44.09	74.00	-29.91	Peak
12	5690.0000	26.30	8.84	35.14	54.00	-18.86	AVG

EUT	IP Phone	Model Name	E6G
Temperature	25°C	Relative Humidity	60%
Test Voltage	DC 48V	Polarization	Horizontal
Test Mode	Handfree		
Note	PoE		
Test Engineer	Jason Yang		

80 dBuV/m

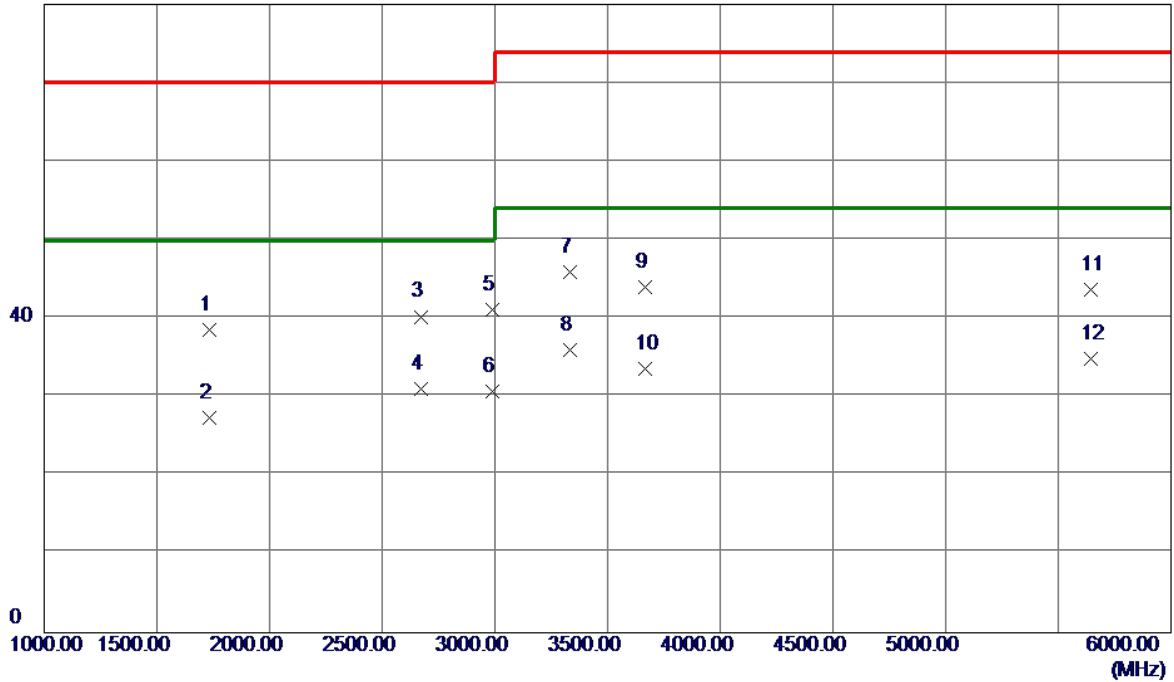

No.	Freq. MHz	Reading Level dBuV/m	Correct Factor dB	Measure ment dBuV/m	Limit dBuV/m	Margin dB	Detector
1	1735.0000	42.53	-3.98	38.55	70.00	-31.45	Peak
2	1735.0000	31.30	-3.98	27.32	50.00	-22.68	AVG
3	2670.0000	39.72	0.52	40.24	70.00	-29.76	Peak
4	2670.0000	30.50	0.52	31.02	50.00	-18.98	AVG
5	2990.0000	38.71	2.36	41.07	70.00	-28.93	Peak
6	2990.0000	28.30	2.36	30.66	50.00	-19.34	AVG
7	3335.0000	43.10	2.86	45.96	74.00	-28.04	Peak
8 *	3335.0000	33.10	2.86	35.96	54.00	-18.04	AVG
9	3665.0000	40.89	3.05	43.94	74.00	-30.06	Peak
10	3665.0000	30.51	3.05	33.56	54.00	-20.44	AVG
11	5645.0000	35.06	8.64	43.70	74.00	-30.30	Peak
12	5645.0000	26.30	8.64	34.94	54.00	-19.06	AVG

EUT	IP Phone	Model Name	E6G
Temperature	25°C	Relative Humidity	60%
Test Voltage	AC 230V/50Hz	Polarization	Vertical
Test Mode	Handfree		
Note	Adapter		
Test Engineer	Jason Yang		

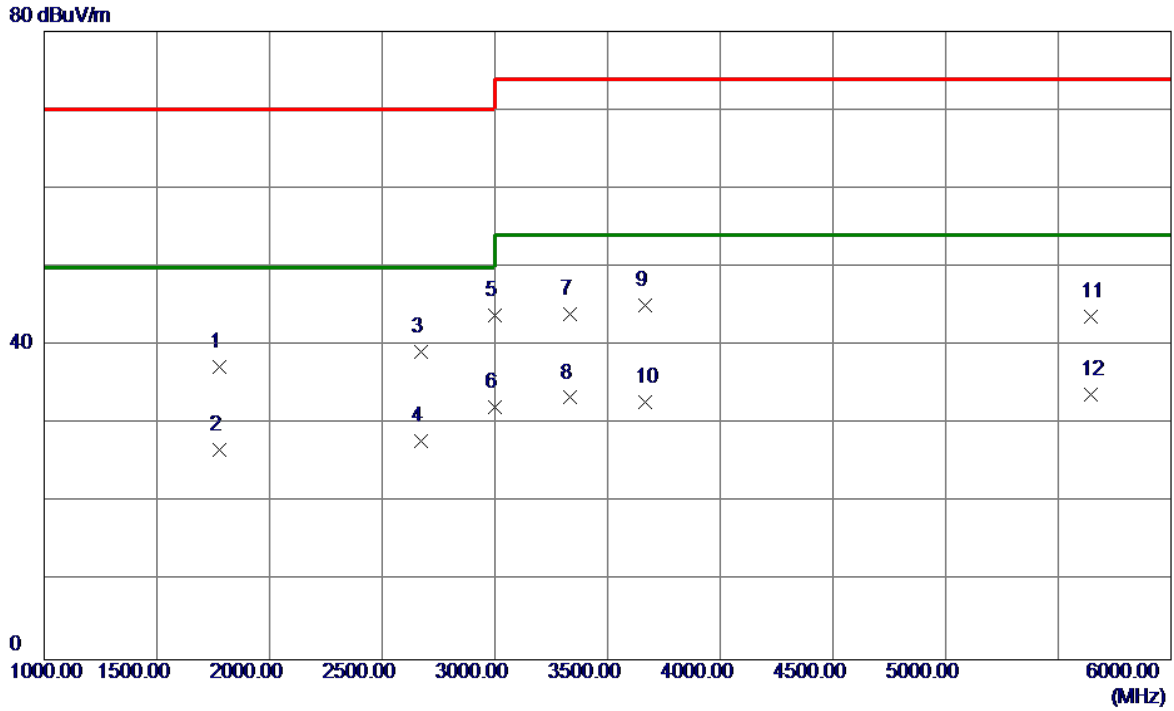

No.	Freq. MHz	Reading Level dBuV/m	Correct Factor dB	Measure ment dBuV/m	Limit dBuV/m	Margin dB	Detector
1	1780.0000	41.03	-3.81	37.22	70.00	-32.78	Peak
2	1780.0000	30.50	-3.81	26.69	50.00	-23.31	AVG
3	2670.0000	38.62	0.52	39.14	70.00	-30.86	Peak
4	2670.0000	27.30	0.52	27.82	50.00	-22.18	AVG
5	3000.0000	41.50	2.42	43.92	70.00	-26.08	Peak
6 *	3000.0000	29.74	2.42	32.16	50.00	-17.84	AVG
7	3335.0000	41.10	2.86	43.96	74.00	-30.04	Peak
8	3335.0000	30.50	2.86	33.36	54.00	-20.64	AVG
9	3665.0000	42.05	3.05	45.10	74.00	-28.90	Peak
10	3665.0000	29.81	3.05	32.86	54.00	-21.14	AVG
11	5645.0000	35.01	8.64	43.65	74.00	-30.35	Peak
12	5645.0000	25.10	8.64	33.74	54.00	-20.26	AVG

EUT	IP Phone	Model Name	E6G
Temperature	25°C	Relative Humidity	60%
Test Voltage	AC 230V/50Hz	Polarization	Horizontal
Test Mode	Handfree		
Note	Adapter		
Test Engineer	Jason Yang		

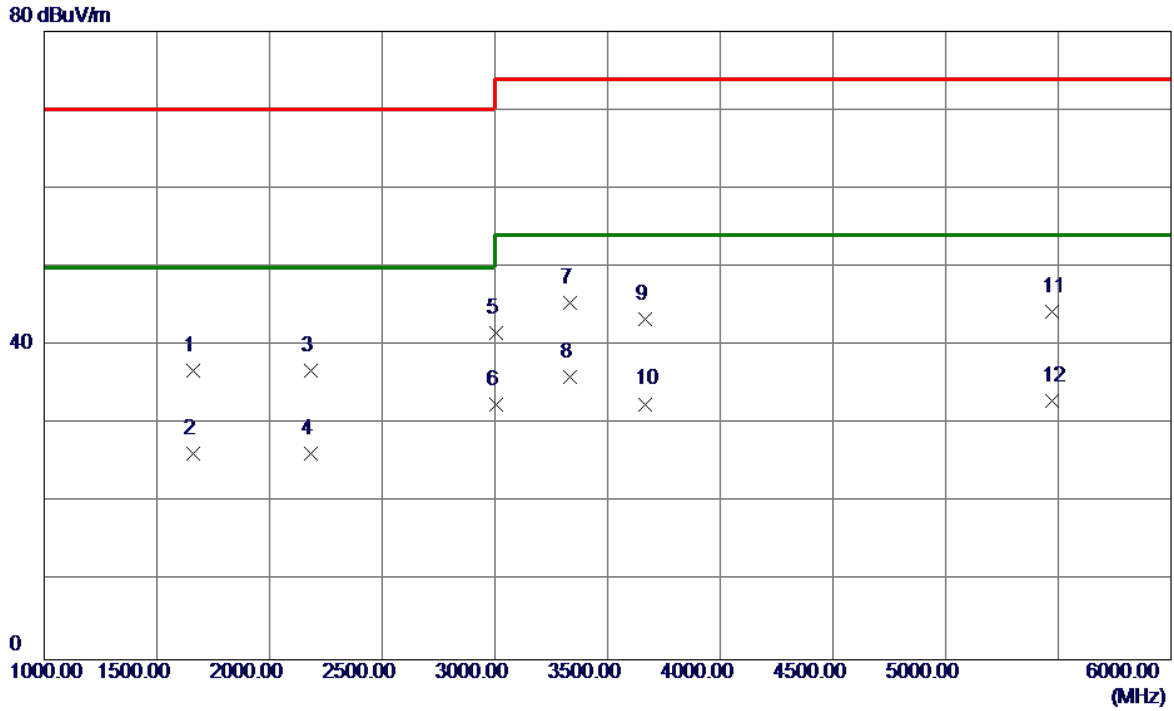

No.	Freq. MHz	Reading Level dBuV/m	Correct Factor dB	Measure ment dBuV/m	Limit dBuV/m	Margin dB	Detector
1	1660.0000	41.10	-4.27	36.83	70.00	-33.17	Peak
2	1660.0000	30.51	-4.27	26.24	50.00	-23.76	AVG
3	2185.0000	38.81	-2.04	36.77	70.00	-33.23	Peak
4	2185.0000	28.30	-2.04	26.26	50.00	-23.74	AVG
5	3005.0000	39.16	2.43	41.59	74.00	-32.41	Peak
6	3005.0000	30.10	2.43	32.53	54.00	-21.47	AVG
7	3335.0000	42.51	2.86	45.37	74.00	-28.63	Peak
8 *	3335.0000	33.10	2.86	35.96	54.00	-18.04	AVG
9	3665.0000	40.27	3.05	43.32	74.00	-30.68	Peak
10	3665.0000	29.51	3.05	32.56	54.00	-21.44	AVG
11	5470.0000	36.49	7.89	44.38	74.00	-29.62	Peak
12	5470.0000	25.09	7.89	32.98	54.00	-21.02	AVG

EUT	IP Phone	Model Name	E6G
Temperature	25°C	Relative Humidity	60%
Test Voltage	DC 48V	Polarization	Vertical
Test Mode	Handset		
Note	PoE		
Test Engineer	Jason Yang		

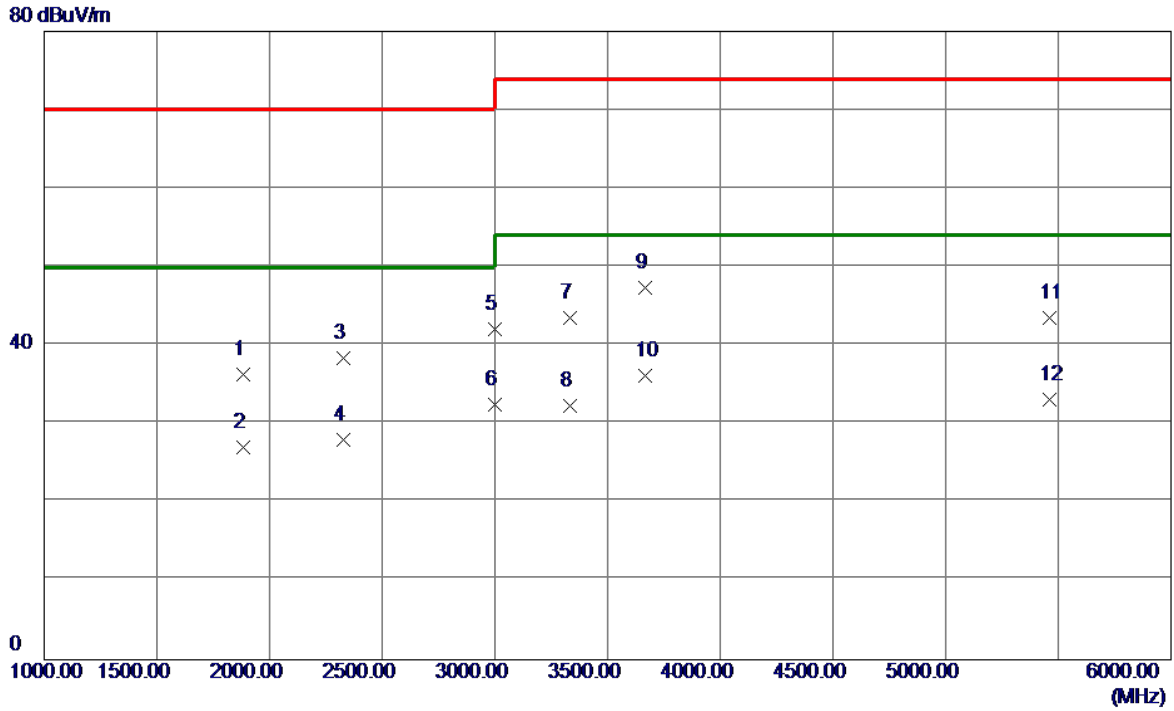

No.	Freq. MHz	Reading Level dBuV/m	Correct Factor dB	Measure ment dBuV/m	Limit dBuV/m	Margin dB	Detector
1	1885.0000	39.76	-3.41	36.35	70.00	-33.65	Peak
2	1885.0000	30.50	-3.41	27.09	50.00	-22.91	AVG
3	2330.0000	39.67	-1.31	38.36	70.00	-31.64	Peak
4	2330.0000	29.30	-1.31	27.99	50.00	-22.01	AVG
5	3000.0000	39.72	2.42	42.14	70.00	-27.86	Peak
6 *	3000.0000	30.10	2.42	32.52	50.00	-17.48	AVG
7	3335.0000	40.69	2.86	43.55	74.00	-30.45	Peak
8	3335.0000	29.50	2.86	32.36	54.00	-21.64	AVG
9	3665.0000	44.33	3.05	47.38	74.00	-26.62	Peak
10	3665.0000	33.11	3.05	36.16	54.00	-17.84	AVG
11	5460.0000	35.60	7.85	43.45	74.00	-30.55	Peak
12	5460.0000	25.30	7.85	33.15	54.00	-20.85	AVG

EUT	IP Phone	Model Name	E6G
Temperature	25°C	Relative Humidity	60%
Test Voltage	DC 48V	Polarization	Horizontal
Test Mode	Handset		
Note	PoE		
Test Engineer	Jason Yang		

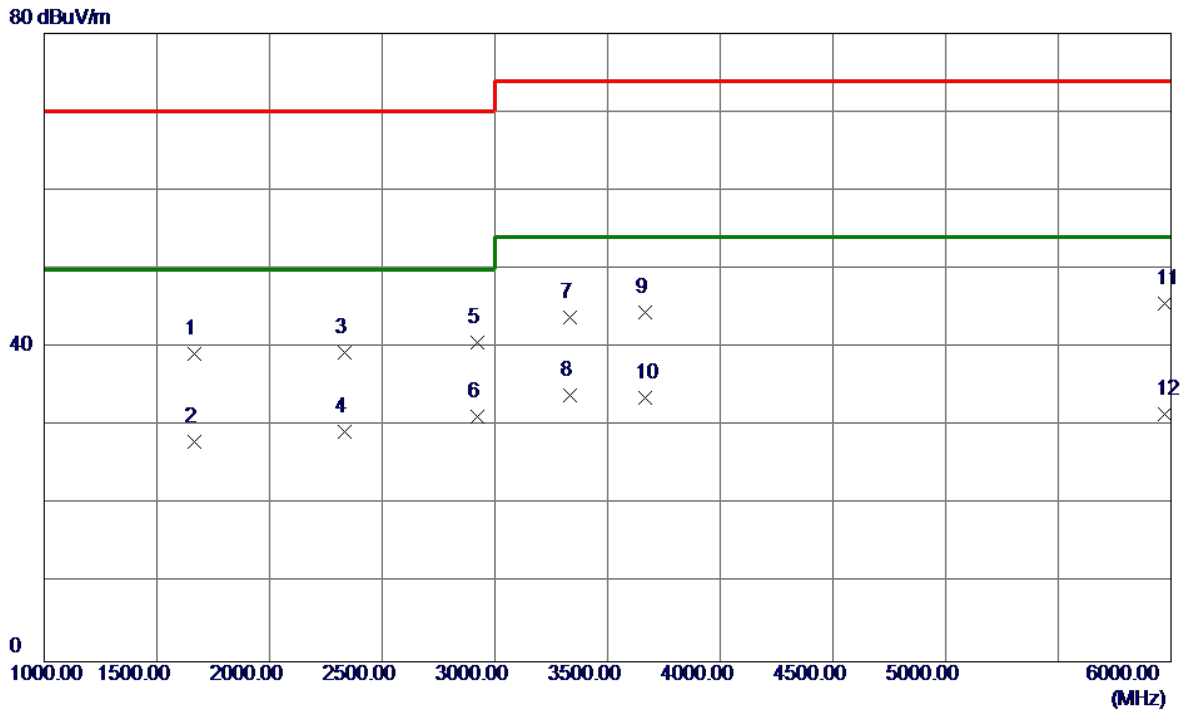

No.	Freq. MHz	Reading Level dBuV/m	Correct Factor dB	Measure ment dBuV/m	Limit dBuV/m	Margin dB	Detector
1	1665.0000	43.49	-4.25	39.24	70.00	-30.76	Peak
2	1665.0000	32.29	-4.25	28.04	50.00	-21.96	AVG
3	2335.0000	40.72	-1.29	39.43	70.00	-30.57	Peak
4	2335.0000	30.50	-1.29	29.21	50.00	-20.79	AVG
5	2920.0000	38.69	1.96	40.65	70.00	-29.35	Peak
6 *	2920.0000	29.30	1.96	31.26	50.00	-18.74	AVG
7	3335.0000	40.95	2.86	43.81	74.00	-30.19	Peak
8	3335.0000	31.10	2.86	33.96	54.00	-20.04	AVG
9	3665.0000	41.37	3.05	44.42	74.00	-29.58	Peak
10	3665.0000	30.51	3.05	33.56	54.00	-20.44	AVG
11	5975.0000	35.44	10.10	45.54	74.00	-28.46	Peak
12	5975.0000	21.49	10.10	31.59	54.00	-22.41	AVG

EUT	IP Phone	Model Name	E6G
Temperature	25°C	Relative Humidity	60%
Test Voltage	AC 230V/50Hz	Polarization	Vertical
Test Mode	Handset		
Note	Adapter		
Test Engineer	Jason Yang		

80 dBuV/m

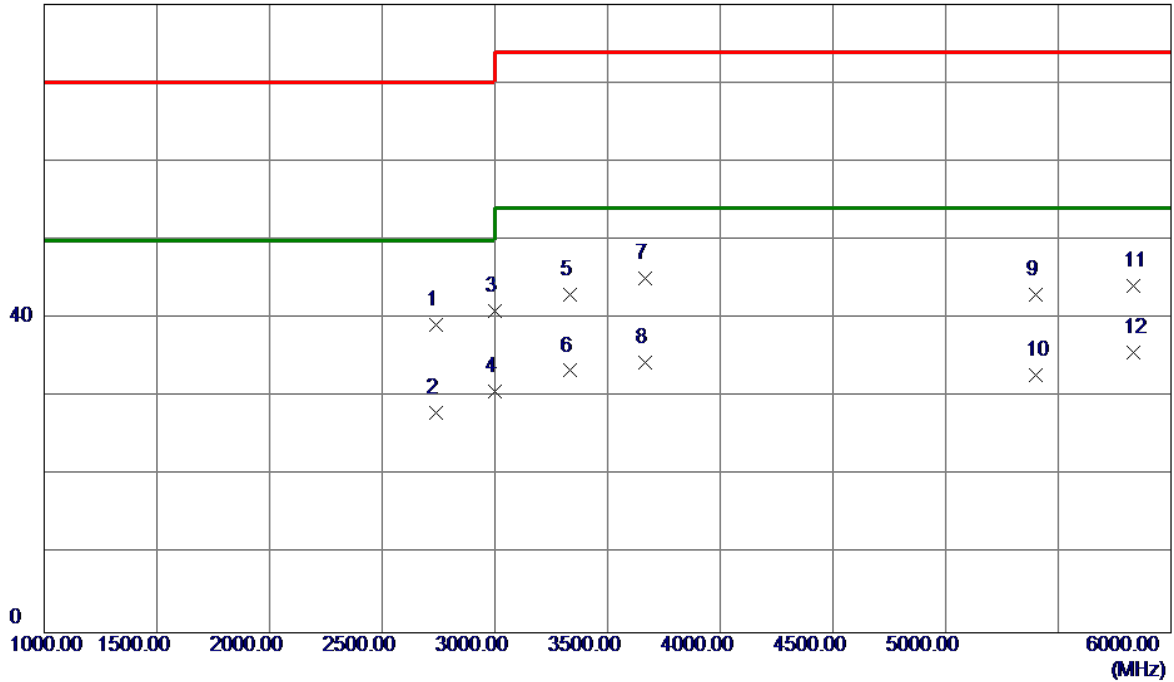

No.	Freq. MHz	Reading Level dBuV/m	Correct Factor dB	Measure ment dBuV/m	Limit dBuV/m	Margin dB	Detector
1	2740.0000	38.32	0.92	39.24	70.00	-30.76	Peak
2	2740.0000	27.10	0.92	28.02	50.00	-21.98	AVG
3	3000.0000	38.56	2.42	40.98	70.00	-29.02	Peak
4	3000.0000	28.30	2.42	30.72	50.00	-19.28	AVG
5	3335.0000	40.11	2.86	42.97	74.00	-31.03	Peak
6	3335.0000	30.50	2.86	33.36	54.00	-20.64	AVG
7	3665.0000	42.14	3.05	45.19	74.00	-28.81	Peak
8	3665.0000	31.31	3.05	34.36	54.00	-19.64	AVG
9	5400.0000	35.46	7.64	43.10	74.00	-30.90	Peak
10	5400.0000	25.10	7.64	32.74	54.00	-21.26	AVG
11	5835.0000	34.69	9.48	44.17	74.00	-29.83	Peak
12 *	5835.0000	26.23	9.48	35.71	54.00	-18.29	AVG

EUT	IP Phone	Model Name	E6G
Temperature	25°C	Relative Humidity	60%
Test Voltage	AC 230V/50Hz	Polarization	Horizontal
Test Mode	Handset		
Note	Adapter		
Test Engineer	Jason Yang		

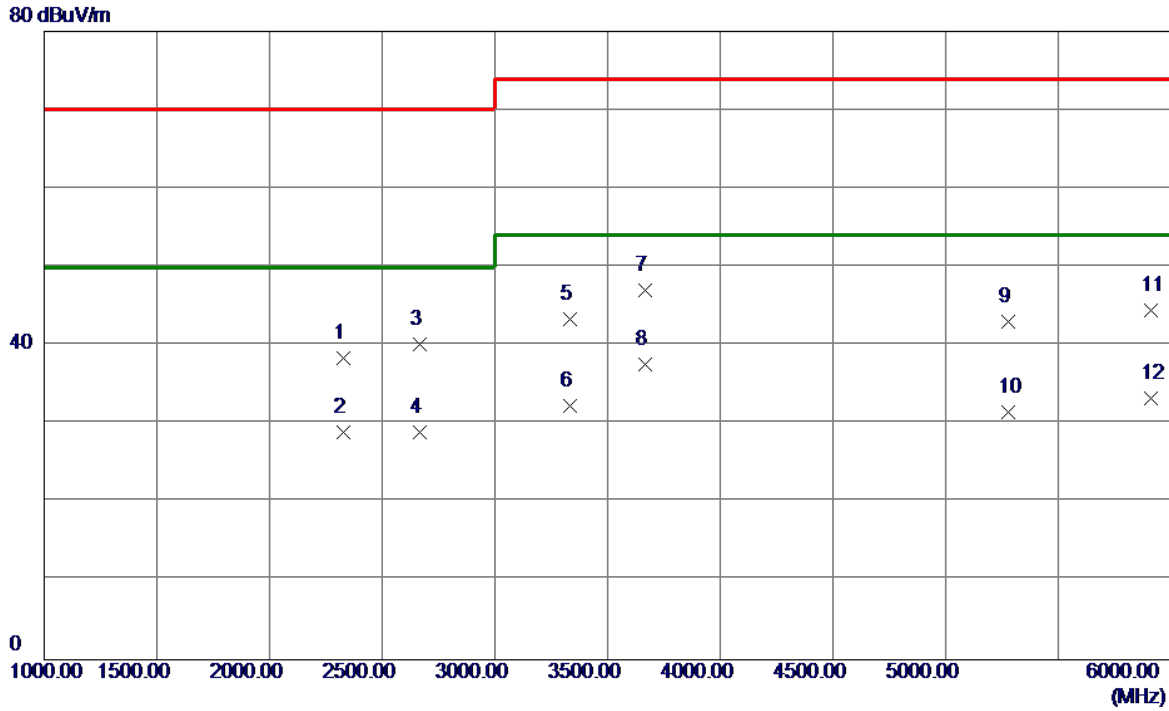

No.	Freq. MHz	Reading Level dBuV/m	Correct Factor dB	Measure ment dBuV/m	Limit dBuV/m	Margin dB	Detector
1	2330.0000	39.66	-1.31	38.35	70.00	-31.65	Peak
2	2330.0000	30.30	-1.31	28.99	50.00	-21.01	AVG
3	2665.0000	39.62	0.49	40.11	70.00	-29.89	Peak
4	2665.0000	28.50	0.49	28.99	50.00	-21.01	AVG
5	3335.0000	40.57	2.86	43.43	74.00	-30.57	Peak
6	3335.0000	29.50	2.86	32.36	54.00	-21.64	AVG
7	3665.0000	43.92	3.05	46.97	74.00	-27.03	Peak
8 *	3665.0000	34.51	3.05	37.56	54.00	-16.44	AVG
9	5280.0000	35.75	7.22	42.97	74.00	-31.03	Peak
10	5280.0000	24.30	7.22	31.52	54.00	-22.48	AVG
11	5910.0000	34.68	9.81	44.49	74.00	-29.51	Peak
12	5910.0000	23.50	9.81	33.31	54.00	-20.69	AVG

EUT	IP Phone	Model Name	E6G
Temperature	25°C	Relative Humidity	60%
Test Voltage	AC 110V/60Hz	Polarization	Vertical
Test Mode	Handset		
Note	Adapter		
Test Engineer	Jason Yang		

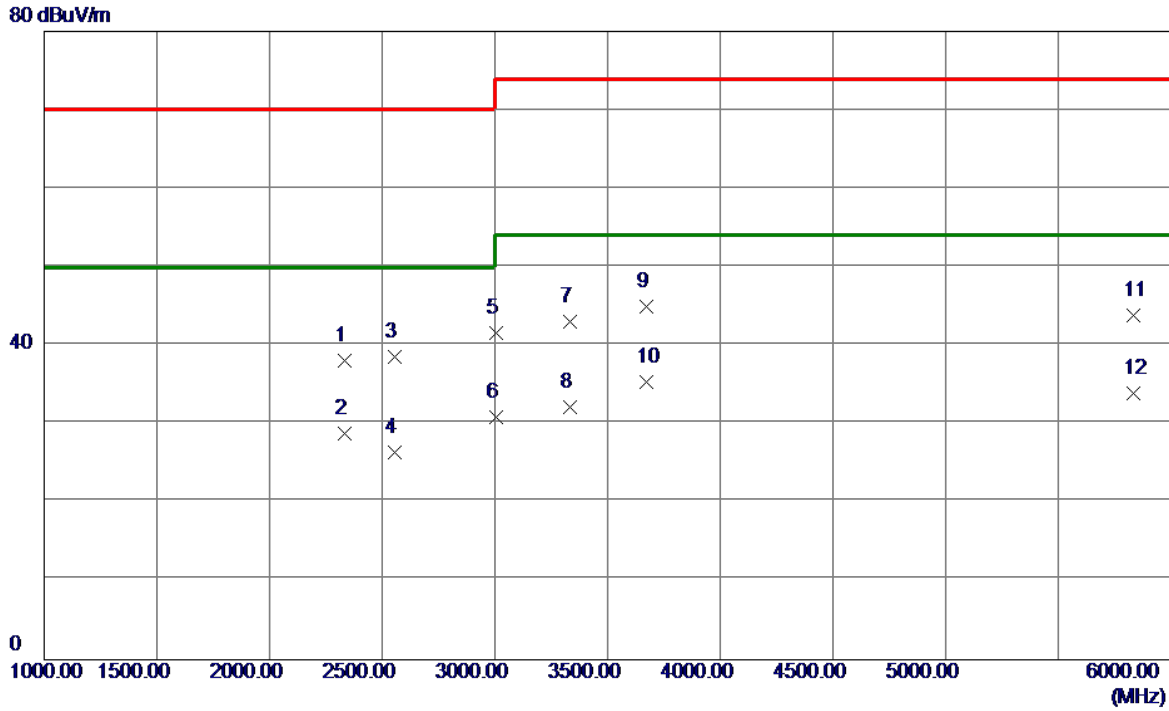

No.	Freq. MHz	Reading Level dBuV/m	Correct Factor dB	Measure ment dBuV/m	Limit dBuV/m	Margin dB	Detector
1	2335.0000	39.38	-1.29	38.09	70.00	-31.91	Peak
2	2335.0000	30.10	-1.29	28.81	50.00	-21.19	AVG
3	2555.0000	38.74	-0.14	38.60	70.00	-31.40	Peak
4	2555.0000	26.49	-0.14	26.35	50.00	-23.65	AVG
5	3005.0000	39.12	2.43	41.55	74.00	-32.45	Peak
6	3005.0000	28.50	2.43	30.93	54.00	-23.07	AVG
7	3335.0000	40.16	2.86	43.02	74.00	-30.98	Peak
8	3335.0000	29.30	2.86	32.16	54.00	-21.84	AVG
9	3670.0000	41.98	3.05	45.03	74.00	-28.97	Peak
10 *	3670.0000	32.30	3.05	35.35	54.00	-18.65	AVG
11	5835.0000	34.41	9.48	43.89	74.00	-30.11	Peak
12	5835.0000	24.51	9.48	33.99	54.00	-20.01	AVG

EUT	IP Phone	Model Name	E6G
Temperature	25°C	Relative Humidity	60%
Test Voltage	AC 110V/60Hz	Polarization	Horizontal
Test Mode	Handset		
Note	Adapter		
Test Engineer	Jason Yang		

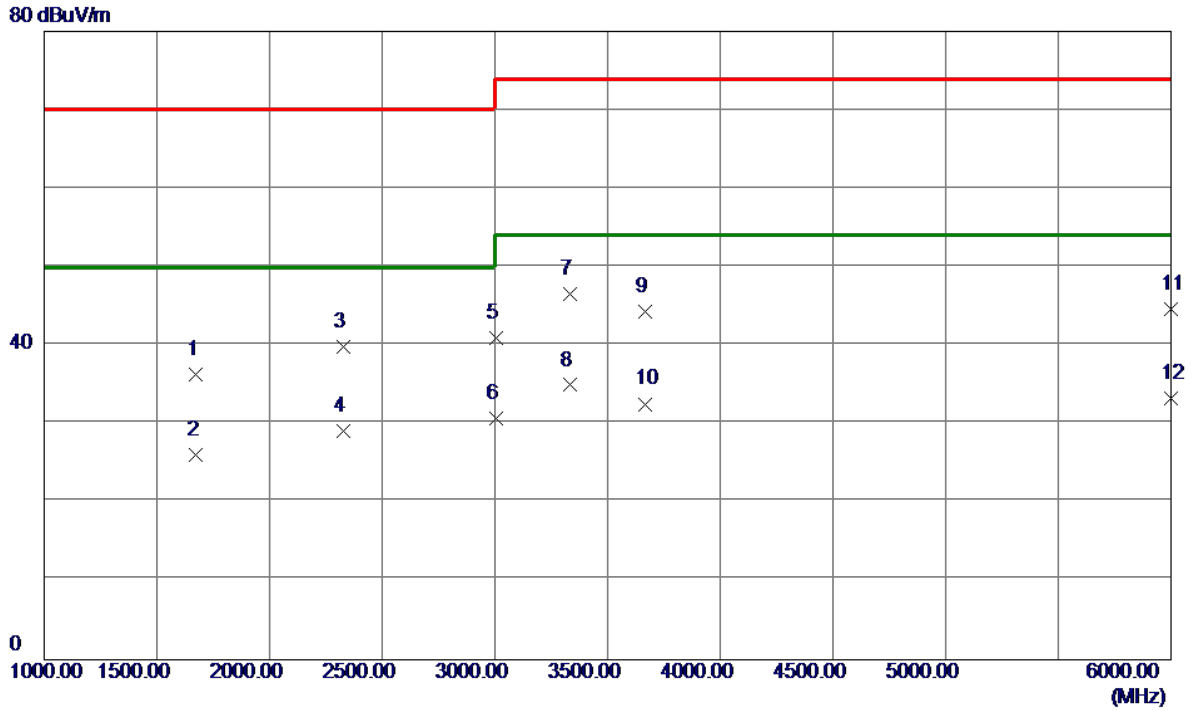

No.	Freq. MHz	Reading Level dBuV/m	Correct Factor dB	Measure ment dBuV/m	Limit dBuV/m	Margin dB	Detector
1	1675.0000	40.52	-4.21	36.31	70.00	-33.69	Peak
2	1675.0000	30.29	-4.21	26.08	50.00	-23.92	AVG
3	2330.0000	41.11	-1.31	39.80	70.00	-30.20	Peak
4	2330.0000	30.50	-1.31	29.19	50.00	-20.81	AVG
5	3005.0000	38.48	2.43	40.91	74.00	-33.09	Peak
6	3005.0000	28.30	2.43	30.73	54.00	-23.27	AVG
7	3335.0000	43.68	2.86	46.54	74.00	-27.46	Peak
8 *	3335.0000	32.10	2.86	34.96	54.00	-19.04	AVG
9	3665.0000	41.34	3.05	44.39	74.00	-29.61	Peak
10	3665.0000	29.51	3.05	32.56	54.00	-21.44	AVG
11	6000.0000	34.36	10.21	44.57	74.00	-29.43	Peak
12	6000.0000	23.10	10.21	33.31	54.00	-20.69	AVG

EUT	IP Phone	Model Name	E6G
Temperature	25°C	Relative Humidity	60%
Test Voltage	DC 48V	Polarization	Vertical
Test Mode	Headphone		
Note	PoE		
Test Engineer	Jason Yang		

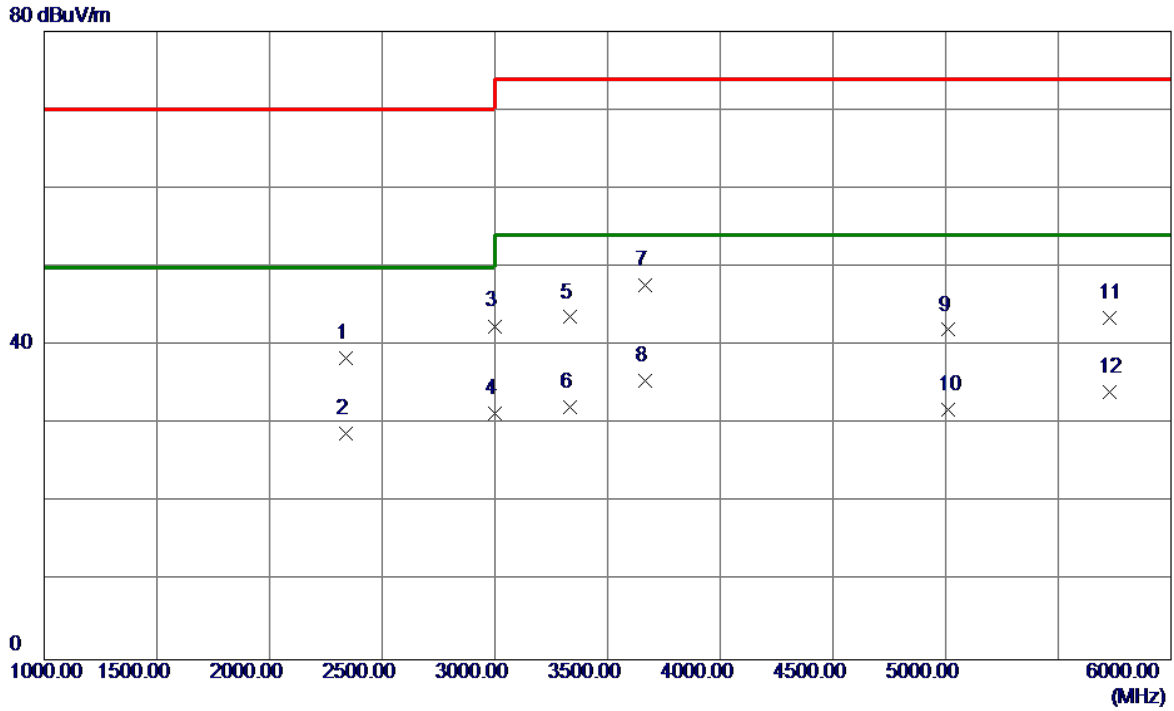

No.	Freq. MHz	Reading Level dBuV/m	Correct Factor dB	Measure ment dBuV/m	Limit dBuV/m	Margin dB	Detector
1	2340.0000	39.71	-1.26	38.45	70.00	-31.55	Peak
2	2340.0000	30.10	-1.26	28.84	50.00	-21.16	AVG
3	3000.0000	40.06	2.42	42.48	70.00	-27.52	Peak
4	3000.0000	28.90	2.42	31.32	50.00	-18.68	AVG
5	3335.0000	40.74	2.86	43.60	74.00	-30.40	Peak
6	3335.0000	29.30	2.86	32.16	54.00	-21.84	AVG
7	3665.0000	44.70	3.05	47.75	74.00	-26.25	Peak
8 *	3665.0000	32.51	3.05	35.56	54.00	-18.44	AVG
9	5010.0000	35.73	6.27	42.00	74.00	-32.00	Peak
10	5010.0000	25.50	6.27	31.77	54.00	-22.23	AVG
11	5725.0000	34.60	8.99	43.59	74.00	-30.41	Peak
12	5725.0000	25.09	8.99	34.08	54.00	-19.92	AVG

EUT	IP Phone	Model Name	E6G
Temperature	25°C	Relative Humidity	60%
Test Voltage	DC 48V	Polarization	Horizontal
Test Mode	Headphone		
Note	PoE		
Test Engineer	Jason Yang		

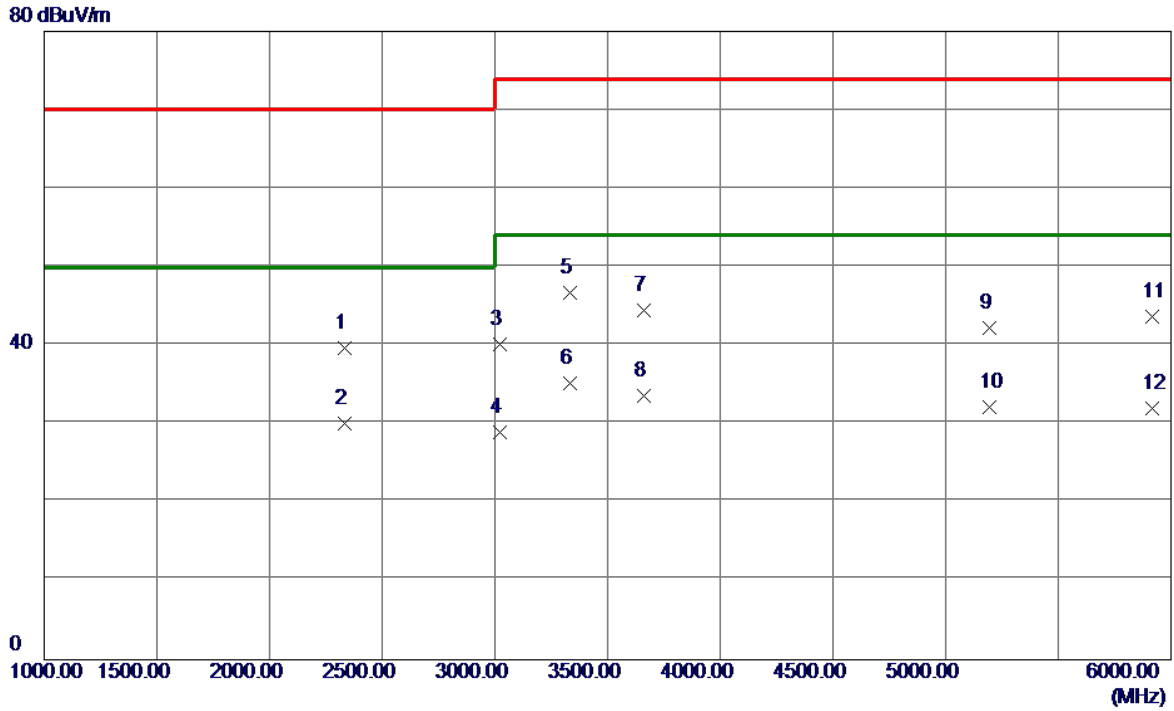

No.	Freq. MHz	Reading Level dBuV/m	Correct Factor dB	Measure ment dBuV/m	Limit dBuV/m	Margin dB	Detector
1	2335.0000	40.94	-1.29	39.65	70.00	-30.35	Peak
2	2335.0000	31.30	-1.29	30.01	50.00	-19.99	AVG
3	3020.0000	37.66	2.45	40.11	74.00	-33.89	Peak
4	3020.0000	26.49	2.45	28.94	54.00	-25.06	AVG
5	3335.0000	43.81	2.86	46.67	74.00	-27.33	Peak
6 *	3335.0000	32.30	2.86	35.16	54.00	-18.84	AVG
7	3660.0000	41.41	3.05	44.46	74.00	-29.54	Peak
8	3660.0000	30.50	3.05	33.55	54.00	-20.45	AVG
9	5195.0000	35.25	6.92	42.17	74.00	-31.83	Peak
10	5195.0000	25.30	6.92	32.22	54.00	-21.78	AVG
11	5915.0000	33.90	9.83	43.73	74.00	-30.27	Peak
12	5915.0000	22.10	9.83	31.93	54.00	-22.07	AVG

EUT	IP Phone	Model Name	E6G
Temperature	25°C	Relative Humidity	60%
Test Voltage	AC 230V/50Hz	Polarization	Vertical
Test Mode	Headphone		
Note	Adapter		
Test Engineer	Jason Yang		

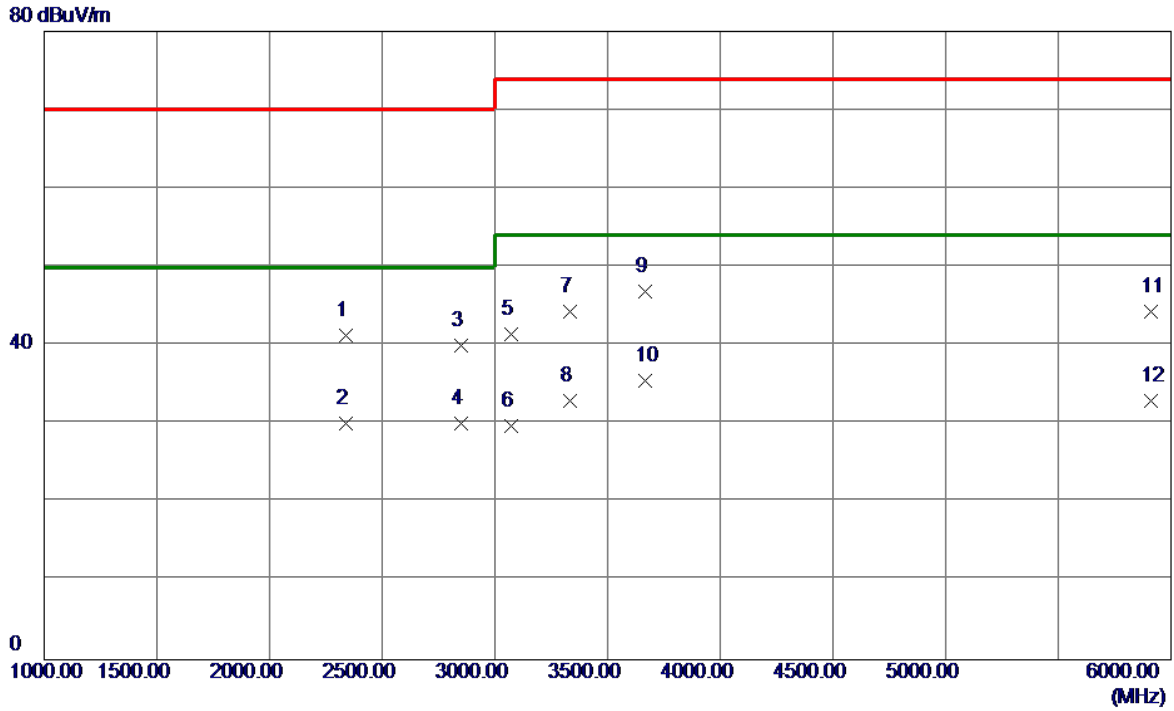

No.	Freq. MHz	Reading Level dBuV/m	Correct Factor dB	Measure ment dBuV/m	Limit dBuV/m	Margin dB	Detector
1	2340.0000	42.60	-1.26	41.34	70.00	-28.66	Peak
2	2340.0000	31.30	-1.26	30.04	50.00	-19.96	AVG
3	2850.0000	38.50	1.56	40.06	70.00	-29.94	Peak
4	2850.0000	28.50	1.56	30.06	50.00	-19.94	AVG
5	3070.0000	38.95	2.51	41.46	74.00	-32.54	Peak
6	3070.0000	27.30	2.51	29.81	54.00	-24.19	AVG
7	3335.0000	41.45	2.86	44.31	74.00	-29.69	Peak
8	3335.0000	30.10	2.86	32.96	54.00	-21.04	AVG
9	3665.0000	43.90	3.05	46.95	74.00	-27.05	Peak
10 *	3665.0000	32.51	3.05	35.56	54.00	-18.44	AVG
11	5910.0000	34.47	9.81	44.28	74.00	-29.72	Peak
12	5910.0000	23.10	9.81	32.91	54.00	-21.09	AVG

EUT	IP Phone	Model Name	E6G
Temperature	25°C	Relative Humidity	60%
Test Voltage	AC 230V/50Hz	Polarization	Horizontal
Test Mode	Headphone		
Note	Adapter		
Test Engineer	Jason Yang		

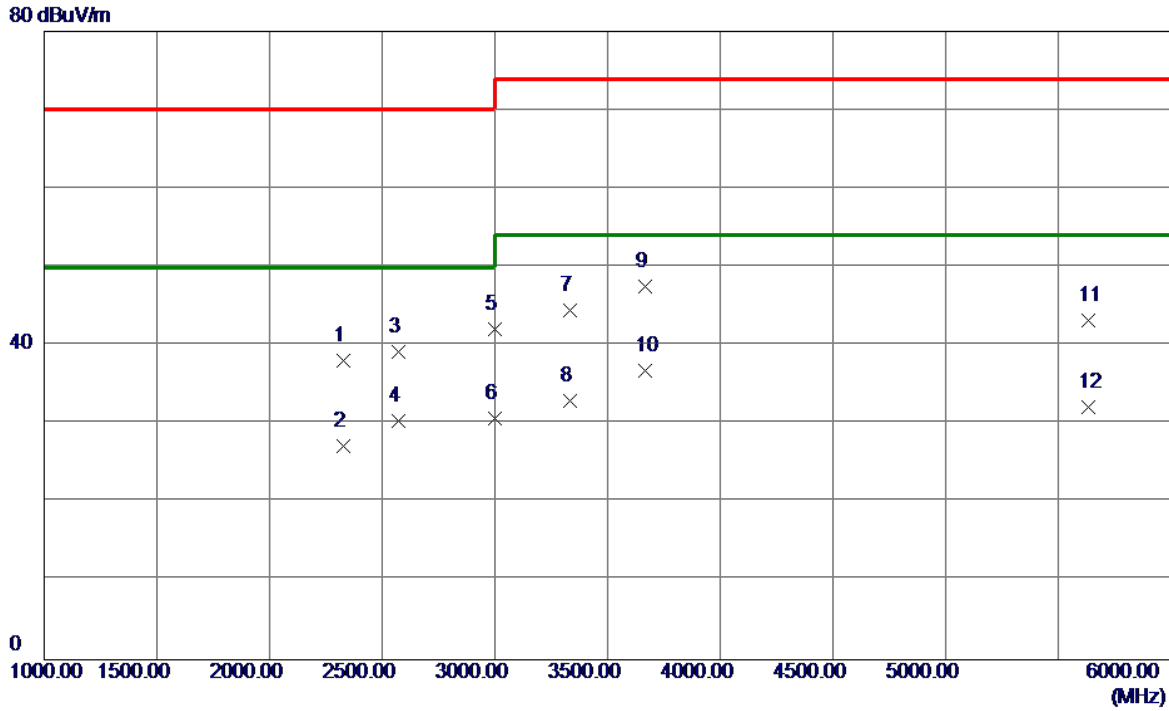

No.	Freq. MHz	Reading Level dBuV/m	Correct Factor dB	Measure ment dBuV/m	Limit dBuV/m	Margin dB	Detector
1	2330.0000	39.44	-1.31	38.13	70.00	-31.87	Peak
2	2330.0000	28.50	-1.31	27.19	50.00	-22.81	AVG
3	2570.0000	39.25	-0.06	39.19	70.00	-30.81	Peak
4	2570.0000	30.51	-0.06	30.45	50.00	-19.55	AVG
5	3000.0000	39.61	2.42	42.03	70.00	-27.97	Peak
6	3000.0000	28.30	2.42	30.72	50.00	-19.28	AVG
7	3335.0000	41.58	2.86	44.44	74.00	-29.56	Peak
8	3335.0000	30.10	2.86	32.96	54.00	-21.04	AVG
9	3665.0000	44.46	3.05	47.51	74.00	-26.49	Peak
10 *	3665.0000	33.79	3.05	36.84	54.00	-17.16	AVG
11	5635.0000	34.67	8.59	43.26	74.00	-30.74	Peak
12	5635.0000	23.50	8.59	32.09	54.00	-21.91	AVG

4.2 CONDUCTED EMISSION MEASUREMENT AT AC MAINS POWER PORTS

4.2.1 LIMITS

Requirements for conducted emissions from AC mains power ports of Class A equipment

Table clause	Frequency Range MHz	Coupling Device	Detector Type / bandwidth	Class A Limits (dB(μV))
A9.1	0.15 - 0.5	AMN	Quasi Peak / 9 kHz	79
	0.5 - 30			73
A9.2	0.15 - 0.5	AMN	Average / 9 kHz	66
	0.5 - 30			60

Apply A9.1 and A9.2 across the entire frequency range.

Requirements for conducted emissions from AC mains power ports of Class B equipment

Table clause	Frequency Range MHz	Coupling Device	Detector Type / bandwidth	Class B Limits (dB(μV))
A10.1	0.15 - 0.5	AMN	Quasi Peak / 9 kHz	66-56
	0.5 - 5			56
	5 - 30			60
A10.2	0.15 - 0.5	AMN	Average / 9 kHz	56-46
	0.5 - 5			46
	5 - 30			50

Apply A10.1 and A10.2 across the entire frequency range.

NOTE:

- (1) The test result calculated as following:
 Measurement Value = Reading Level + Correct Factor
 Correct Factor = Insertion Loss + Cable Loss + Attenuator Factor(if use)
 Margin Level = Measurement Value – Limit Value

4.2.2 MEASUREMENT INSTRUMENTS LIST

Item	Kind of Equipment	Manufacturer	Type No.	Serial No.	Calibrated until
1	EMI Test Receiver	R&S	ESCI	100382	Mar. 26, 2018
2	LISN	EMCO	3816/2	52765	Mar. 26, 2018
3	50Ω Terminator	SHX	TF2-3G-A	8122901	Mar. 26, 2018
4	TWO-LINE V-NETWORK	R&S	ENV216	101447	Mar. 26, 2018
5	Measurement Software	Farad	EZ-EMC Ver.NB-03A 1-01	N/A	N/A
6	Cable	N/A	RG223	12m	Oct. 19, 2018

Remark: "N/A" denotes no model name, no serial no. or no calibration specified.
 All calibration period of equipment list is one year.

4.2.3 TEST PROCEDURE

- The EUT was placed 0.8 meters from the horizontal ground plane with EUT being connected to the power mains through a line impedance stabilization network (LISN). All other support equipments powered from additional LISN(s). The LISN provide 50 Ohm/ 50uH of coupling impedance for the measuring instrument.
- Interconnecting cables that hang closer than 40 cm to the ground plane shall be folded back and forth in the center forming a bundle 30 to 40 cm long.
- I/O cables that are not connected to a peripheral shall be bundled in the center. The end of the cable may be terminated, if required, using the correct terminating impedance. The overall length shall not exceed 1 m.
- LISN at least 80 cm from nearest part of EUT chassis.
- For the actual test configuration, please refer to the related Item –EUT Test Photos.

4.2.4 DEVIATION FROM TEST STANDARD

No deviation

4.2.5 TEST SETUP

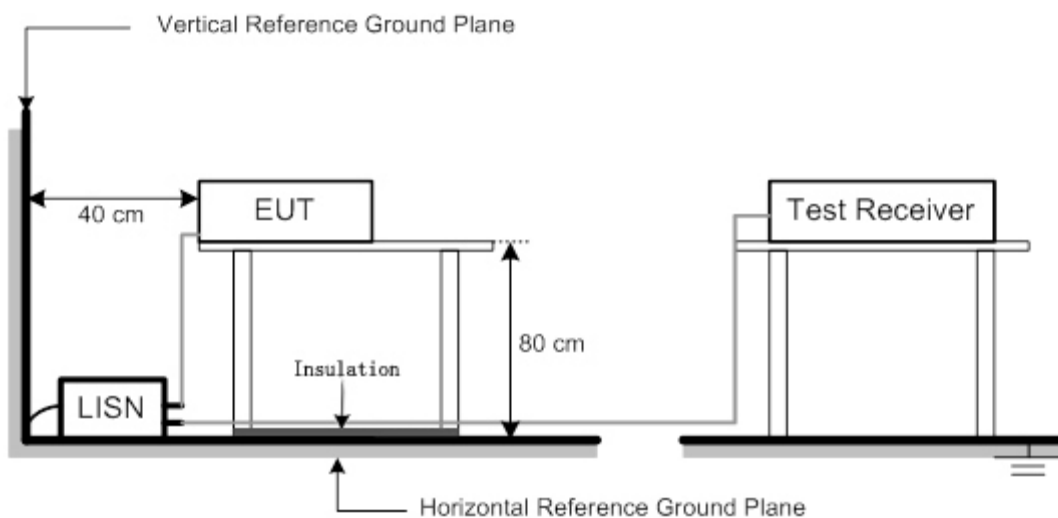

4.2.6 TEST RESULTS

EUT	IP Phone	Model Name	E6G
Temperature	25°C	Relative Humidity	53%
Test Voltage	AC 230V/50Hz	Phase	Line
Test Mode	Handfree		
Note	Adapter		
Test Engineer	Jason Yang		

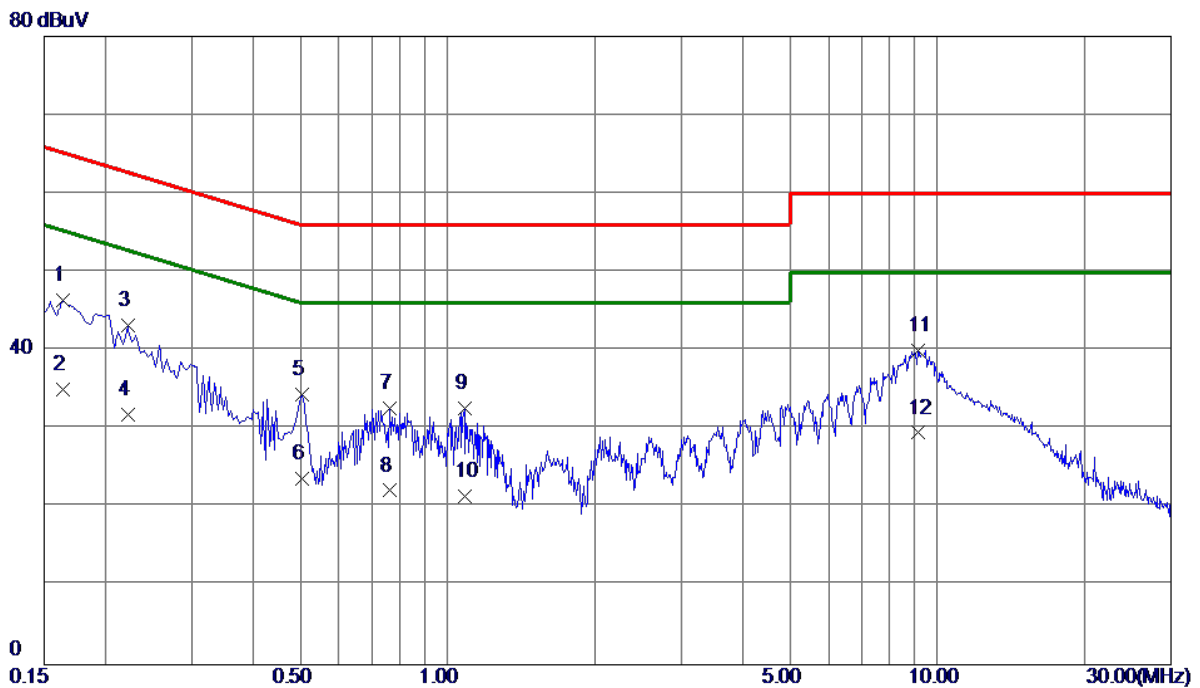

No.	Freq. MHz	Reading Level dBuV	Correct Factor dB	Measure ment dBuV	Limit dBuV	Margin dB	Detector
1 *	0.1635	36.62	9.74	46.36	65.28	-18.92	QP
2	0.1635	25.30	9.74	35.04	55.28	-20.24	AVG
3	0.2220	33.43	9.72	43.15	62.74	-19.59	QP
4	0.2220	22.10	9.72	31.82	52.74	-20.92	AVG
5	0.5055	24.67	9.76	34.43	56.00	-21.57	QP
6	0.5055	13.90	9.76	23.66	46.00	-22.34	AVG
7	0.7620	22.87	9.76	32.63	56.00	-23.37	QP
8	0.7620	12.40	9.76	22.16	46.00	-23.84	AVG
9	1.0815	22.86	9.78	32.64	56.00	-23.36	QP
10	1.0815	11.60	9.78	21.38	46.00	-24.62	AVG
11	9.1365	30.02	10.02	40.04	60.00	-19.96	QP
12	9.1365	19.50	10.02	29.52	50.00	-20.48	AVG

EUT	IP Phone	Model Name	E6G
Temperature	25°C	Relative Humidity	53%
Test Voltage	AC 230V/50Hz	Phase	Neutral
Test Mode	Handfree		
Note	Adapter		
Test Engineer	Jason Yang		

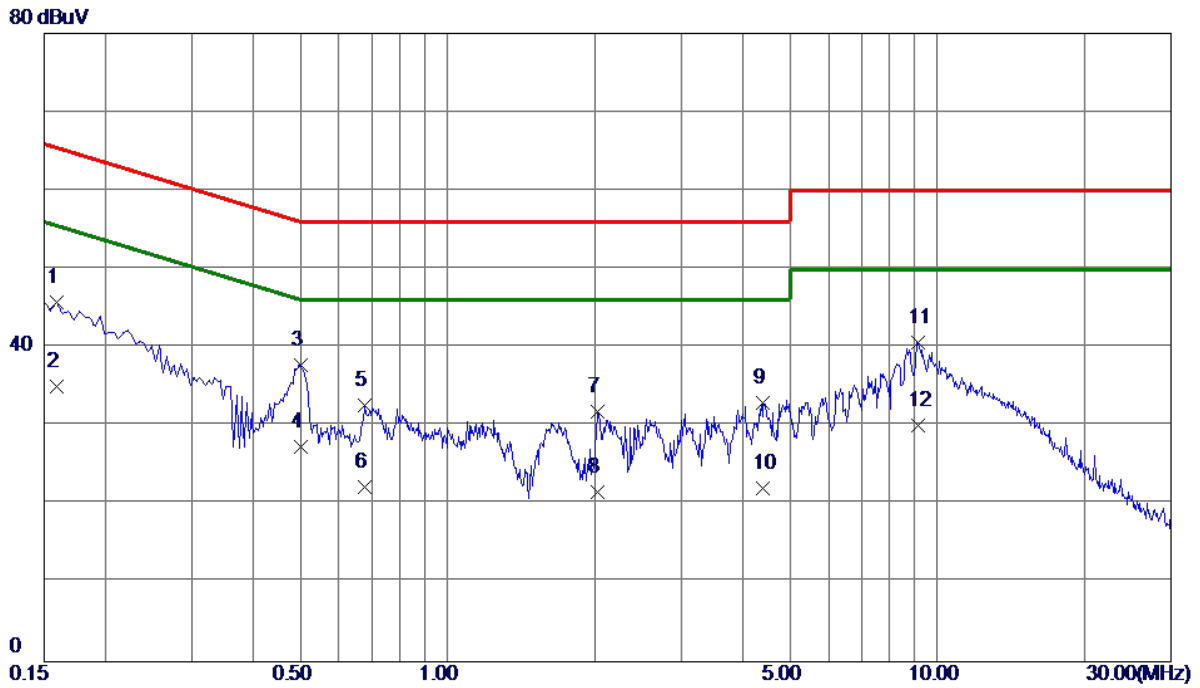

No.	Freq. MHz	Reading Level dBuV	Correct Factor dB	Measure ment dBuV	Limit dBuV	Margin dB	Detector
1	0.1590	36.19	9.64	45.83	65.52	-19.69	QP
2	0.1590	25.40	9.64	35.04	55.52	-20.48	AVG
3 *	0.5010	28.11	9.66	37.77	56.00	-18.23	QP
4	0.5010	17.70	9.66	27.36	46.00	-18.64	AVG
5	0.6765	23.04	9.67	32.71	56.00	-23.29	QP
6	0.6765	12.60	9.67	22.27	46.00	-23.73	AVG
7	2.0264	22.07	9.73	31.80	56.00	-24.20	QP
8	2.0264	11.80	9.73	21.53	46.00	-24.47	AVG
9	4.4115	23.14	9.80	32.94	56.00	-23.06	QP
10	4.4115	12.30	9.80	22.10	46.00	-23.90	AVG
11	9.1230	30.66	9.96	40.62	60.00	-19.38	QP
12	9.1230	20.10	9.96	30.06	50.00	-19.94	AVG

EUT	IP Phone	Model Name	E6G
Temperature	25°C	Relative Humidity	53%
Test Voltage	AC 230V/50Hz	Phase	Line
Test Mode	Handset		
Note	Adapter		
Test Engineer	Jason Yang		

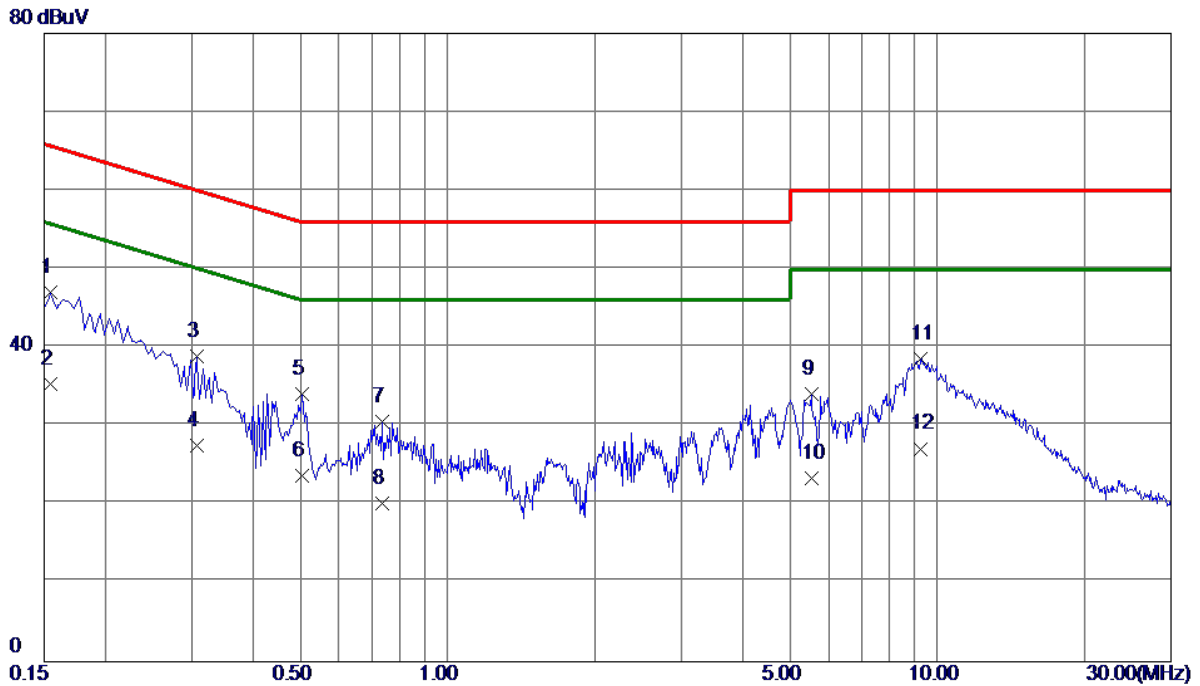

No.	Freq. MHz	Reading Level dBuV	Correct Factor dB	Measure ment dBuV	Limit dBuV	Margin dB	Detector
1 *	0.1545	37.26	9.75	47.01	65.75	-18.74	QP
2	0.1545	25.60	9.75	35.35	55.75	-20.40	AVG
3	0.3075	29.17	9.72	38.89	60.04	-21.15	QP
4	0.3075	17.80	9.72	27.52	50.04	-22.52	AVG
5	0.5055	24.29	9.76	34.05	56.00	-21.95	QP
6	0.5055	13.90	9.76	23.66	46.00	-22.34	AVG
7	0.7350	20.74	9.76	30.50	56.00	-25.50	QP
8	0.7350	10.41	9.76	20.17	46.00	-25.83	AVG
9	5.5275	24.14	9.91	34.05	60.00	-25.95	QP
10	5.5275	13.50	9.91	23.41	50.00	-26.59	AVG
11	9.2490	28.55	10.02	38.57	60.00	-21.43	QP
12	9.2490	17.10	10.02	27.12	50.00	-22.88	AVG

EUT	IP Phone	Model Name	E6G
Temperature	25°C	Relative Humidity	53%
Test Voltage	AC 230V/50Hz	Phase	Neutral
Test Mode	Handset		
Note	Adapter		
Test Engineer	Jason Yang		

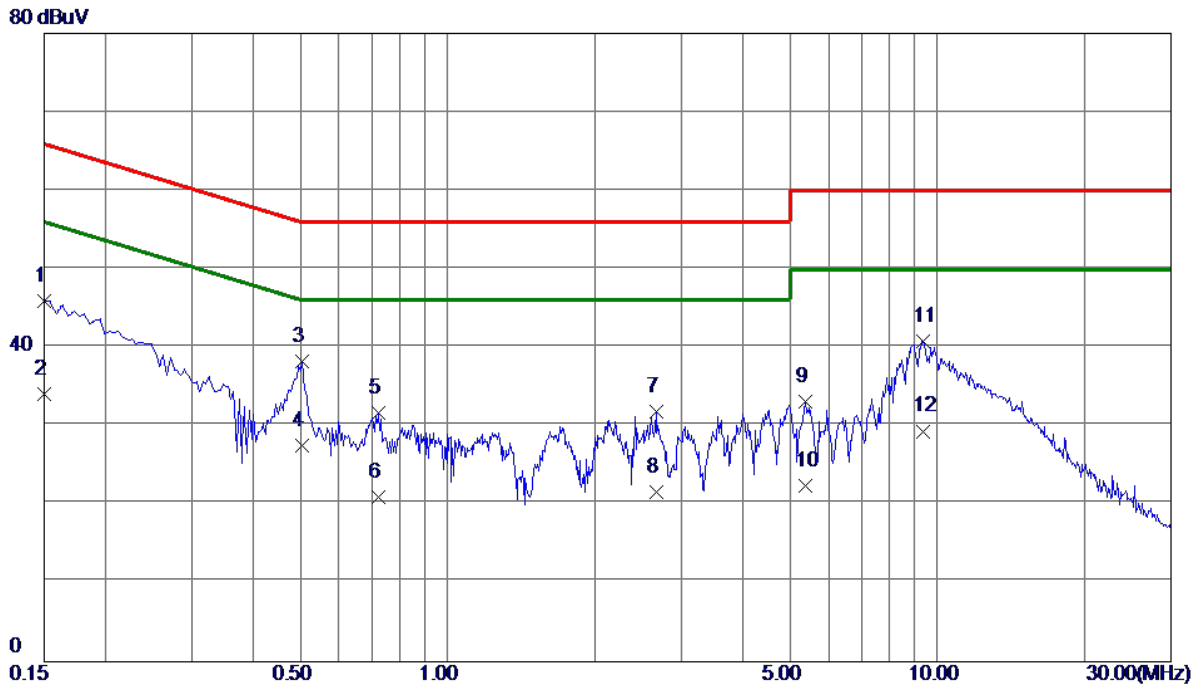

No.	Freq. MHz	Reading Level dBuV	Correct Factor dB	Measure ment dBuV	Limit dBuV	Margin dB	Detector
1	0.1500	36.22	9.64	45.86	66.00	-20.14	QP
2	0.1500	24.50	9.64	34.14	56.00	-21.86	AVG
3 *	0.5055	28.53	9.66	38.19	56.00	-17.81	QP
4	0.5055	17.90	9.66	27.56	46.00	-18.44	AVG
5	0.7215	22.00	9.67	31.67	56.00	-24.33	QP
6	0.7215	11.30	9.67	20.97	46.00	-25.03	AVG
7	2.6610	22.03	9.74	31.77	56.00	-24.23	QP
8	2.6610	11.80	9.74	21.54	46.00	-24.46	AVG
9	5.3880	23.26	9.83	33.09	60.00	-26.91	QP
10	5.3880	12.60	9.83	22.43	50.00	-27.57	AVG
11	9.3525	30.85	9.96	40.81	60.00	-19.19	QP
12	9.3525	19.40	9.96	29.36	50.00	-20.64	AVG

EUT	IP Phone	Model Name	E6G
Temperature	25°C	Relative Humidity	53%
Test Voltage	AC 110V/60Hz	Phase	Line
Test Mode	Handset		
Note	Adapter		
Test Engineer	Jason Yang		

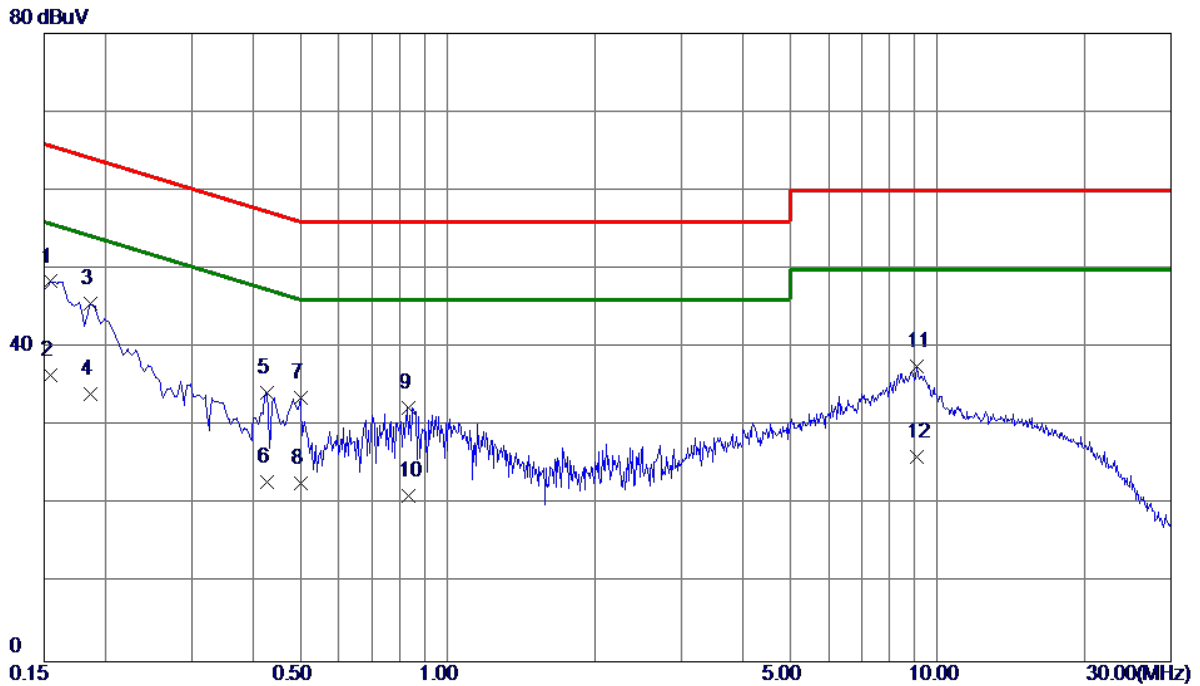

No.	Freq. MHz	Reading Level dBuV	Correct Factor dB	Measure ment dBuV	Limit dBuV	Margin dB	Detector
1 *	0.1545	38.65	9.75	48.40	65.75	-17.35	QP
2	0.1545	26.70	9.75	36.45	55.75	-19.30	AVG
3	0.1860	35.79	9.73	45.52	64.21	-18.69	QP
4	0.1860	24.30	9.73	34.03	54.21	-20.18	AVG
5	0.4290	24.54	9.76	34.30	57.27	-22.97	QP
6	0.4290	13.20	9.76	22.96	47.27	-24.31	AVG
7	0.5010	23.78	9.76	33.54	56.00	-22.46	QP
8	0.5010	12.90	9.76	22.66	46.00	-23.34	AVG
9	0.8295	22.52	9.77	32.29	56.00	-23.71	QP
10	0.8295	11.40	9.77	21.17	46.00	-24.83	AVG
11	9.0780	27.52	10.01	37.53	60.00	-22.47	QP
12	9.0780	16.10	10.01	26.11	50.00	-23.89	AVG

EUT	IP Phone	Model Name	E6G
Temperature	25°C	Relative Humidity	53%
Test Voltage	AC 110V/60Hz	Phase	Neutral
Test Mode	Handset		
Note	Adapter		
Test Engineer	Jason Yang		

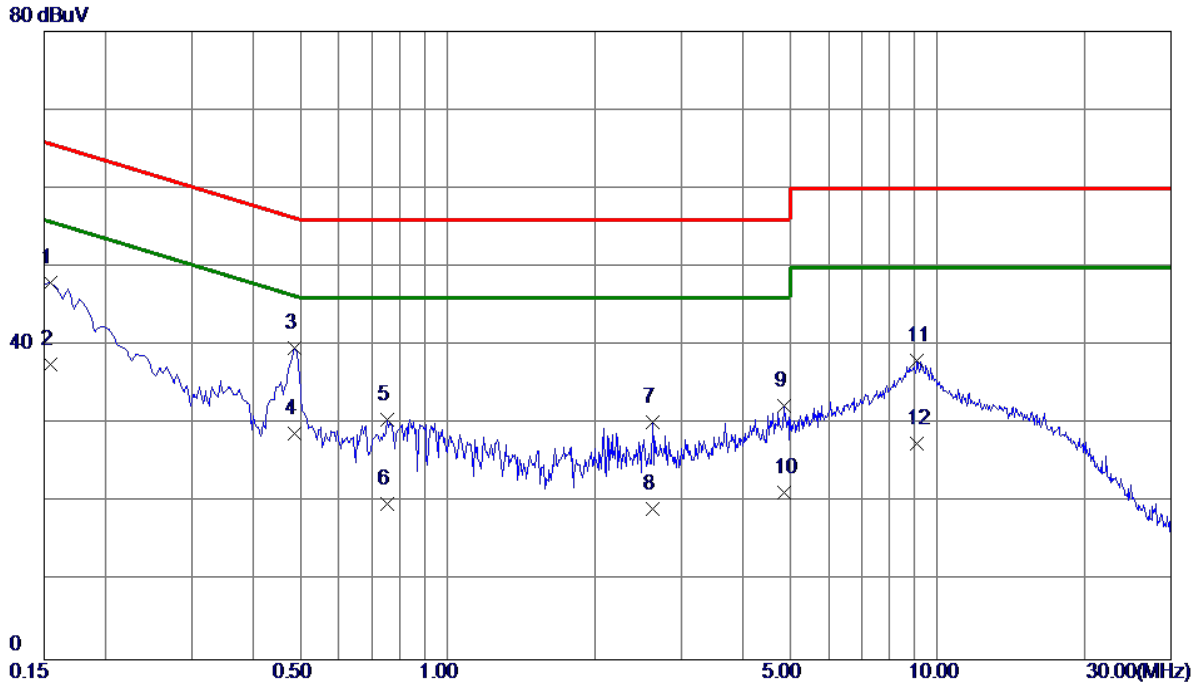

No.	Freq. MHz	Reading Level dBuV	Correct Factor dB	Measure ment dBuV	Limit dBuV	Margin dB	Detector
1	0.1545	38.36	9.64	48.00	65.75	-17.75	QP
2	0.1545	27.90	9.64	37.54	55.75	-18.21	AVG
3 *	0.4875	30.00	9.66	39.66	56.21	-16.55	QP
4	0.4875	19.20	9.66	28.86	46.21	-17.35	AVG
5	0.7530	20.83	9.66	30.49	56.00	-25.51	QP
6	0.7530	10.20	9.66	19.86	46.00	-26.14	AVG
7	2.6204	20.56	9.74	30.30	56.00	-25.70	QP
8	2.6204	9.50	9.74	19.24	46.00	-26.76	AVG
9	4.8525	22.50	9.82	32.32	56.00	-23.68	QP
10	4.8525	11.40	9.82	21.22	46.00	-24.78	AVG
11	9.0870	28.14	9.95	38.09	60.00	-21.91	QP
12	9.0870	17.61	9.95	27.56	50.00	-22.44	AVG

EUT	IP Phone	Model Name	E6G
Temperature	25°C	Relative Humidity	53%
Test Voltage	AC 230V/50Hz	Phase	Line
Test Mode	Headphone		
Note	Adapter		
Test Engineer	Jason Yang		

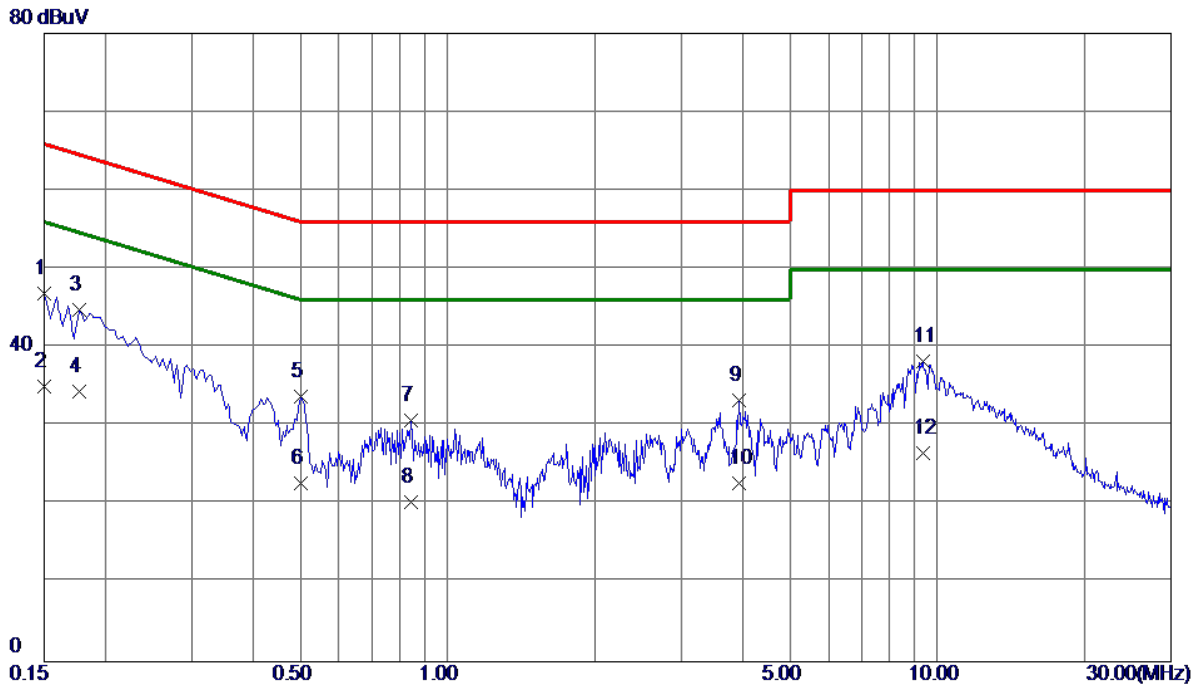

No.	Freq. MHz	Reading Level dBuV	Correct Factor dB	Measure ment dBuV	Limit dBuV	Margin dB	Detector
1 *	0.1500	37.10	9.75	46.85	66.00	-19.15	QP
2	0.1500	25.30	9.75	35.05	56.00	-20.95	AVG
3	0.1770	35.08	9.74	44.82	64.63	-19.81	QP
4	0.1770	24.70	9.74	34.44	54.63	-20.19	AVG
5	0.5010	23.94	9.76	33.70	56.00	-22.30	QP
6	0.5010	12.90	9.76	22.66	46.00	-23.34	AVG
7	0.8430	20.93	9.77	30.70	56.00	-25.30	QP
8	0.8430	10.50	9.77	20.27	46.00	-25.73	AVG
9	3.9390	23.35	9.86	33.21	56.00	-22.79	QP
10	3.9390	12.80	9.86	22.66	46.00	-23.34	AVG
11	9.3300	28.25	10.02	38.27	60.00	-21.73	QP
12	9.3300	16.60	10.02	26.62	50.00	-23.38	AVG

EUT	IP Phone	Model Name	E6G
Temperature	25°C	Relative Humidity	53%
Test Voltage	AC 230V/50Hz	Phase	Neutral
Test Mode	Headphone		
Note	Adapter		
Test Engineer	Jason Yang		

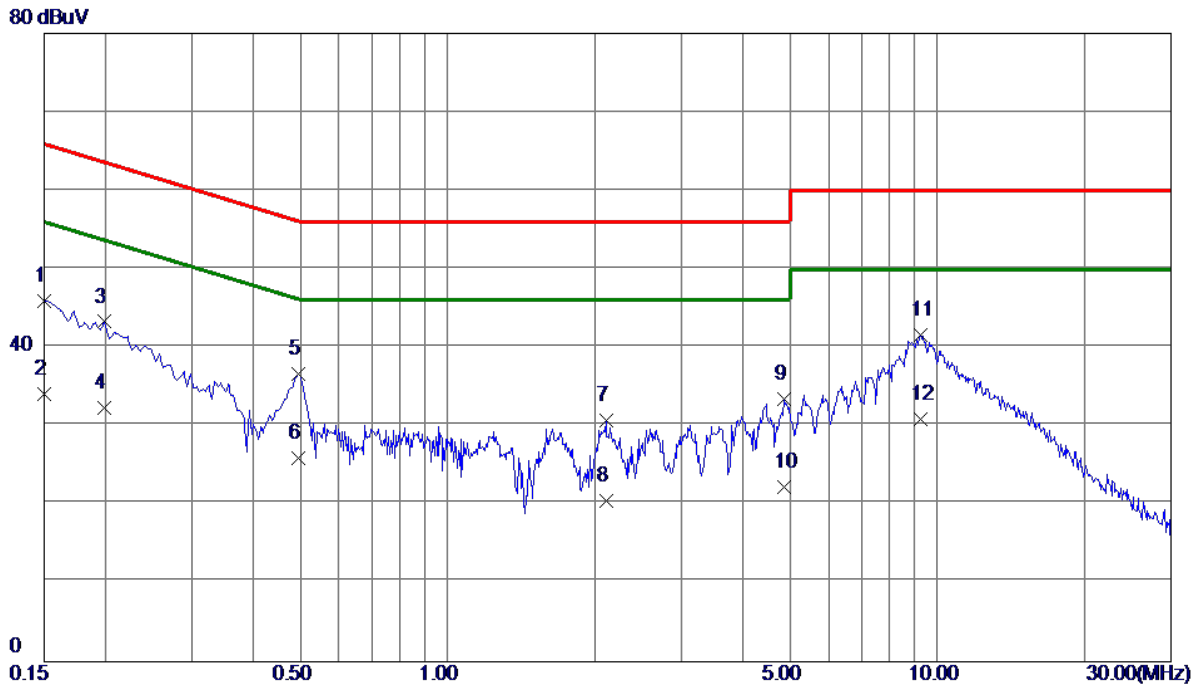

No.	Freq. MHz	Reading Level dBuV	Correct Factor dB	Measure ment dBuV	Limit dBuV	Margin dB	Detector
1	0.1500	36.35	9.64	45.99	66.00	-20.01	QP
2	0.1500	24.50	9.64	34.14	56.00	-21.86	AVG
3	0.1995	33.63	9.65	43.28	63.63	-20.35	QP
4	0.1995	22.70	9.65	32.35	53.63	-21.28	AVG
5	0.4965	27.03	9.66	36.69	56.06	-19.37	QP
6	0.4965	16.20	9.66	25.86	46.06	-20.20	AVG
7	2.1030	20.94	9.73	30.67	56.00	-25.33	QP
8	2.1030	10.80	9.73	20.53	46.00	-25.47	AVG
9	4.8525	23.57	9.82	33.39	56.00	-22.61	QP
10	4.8525	12.40	9.82	22.22	46.00	-23.78	AVG
11 *	9.2490	31.57	9.96	41.53	60.00	-18.47	QP
12	9.2490	20.90	9.96	30.86	50.00	-19.14	AVG

4.3 ASYMMETRIC MODE CONDUCTED EMISSIONS TEST

4.3.1 LIMITS

Requirements for asymmetric mode conducted emissions from Class A equipment

Table clause	Frequency range MHz	Coupling device	Detector type / Bandwidth	Class A voltage limits dB(μV)	Class A current limits dB(μV)
A11.1	0.15 – 0.5	AAN	Quasi Peak / 9 kHz	97 – 87	n/a
	0.5 – 30			87	
	0.15 – 0.5	AAN	Average / 9 kHz	84 – 74	
	0.5 – 30			74	
A11.2	0.15 – 0.5	CVP and current probe	Quasi Peak / 9 kHz	97 – 87	53 – 43
	0.5 – 30			87	43
	0.15 – 0.5	CVP and current probe	Average / 9 kHz	84 – 74	40 – 30
	0.5 – 30			74	30
A11.3	0.15 – 0.5	Current probe	Quasi Peak / 9 kHz	n/a	53 – 43
	0.5 – 30				43
	0.15 – 0.5	Current probe	Average / 9 kHz		40 – 30
	0.5 – 30				30

The choice of coupling device and measurement procedure is defined in Annex C.

AC mains ports that also have the function of a wired network port shall meet the limits given in Table A.9. The measurement shall cover the entire frequency range.

The application of the voltage and/or current limits is dependent on the measurement procedure used. Refer to Table C.1 for applicability.

Testing is required at only one EUT supply voltage and frequency.

Applicable to ports listed above and intended to connect to cables longer than 3 m.

Requirements for asymmetric mode conducted emissions from Class B equipment

Table clause	Frequency range MHz	Coupling device	Detector type / Bandwidth	Class B voltage limits dB(μV)	Class B current limits dB(μV)
A12.1	0.15 – 0.5	AAN	Quasi Peak / 9 kHz	84 – 74	n/a
	0.5 – 30			74	
	0.15 – 0.5	AAN	Average / 9 kHz	74 – 64	
	0.5 – 30			64	
A12.2	0.15 – 0.5	CVP and current probe	Quasi Peak / 9 kHz	84 – 74	40 – 30
	0.5 – 30			74	30
	0.15 – 0.5	CVP and current probe	Average / 9 kHz	74 – 64	30 – 20
	0.5 – 30			64	20
A12.3	0.15 – 0.5	Current probe	Quasi Peak / 9 kHz	n/a	40 – 30
	0.5 – 30				30
	0.15 – 0.5	Current probe	Average / 9 kHz		30 – 20
	0.5 – 30				20

The choice of coupling device and measurement procedure is defined in Annex C.

Screened ports including TV broadcast receiver tuner ports are measured with a common-mode impedance of 150 Ω. This is typically accomplished with the screen terminated by 150 Ω to earth.

AC mains ports that also have the function of a wired network port shall meet the limits given in Table A.10.

The measurement shall cover the entire frequency range.

The application of the voltage and/or current limits is dependent on the measurement procedure used. Refer to Table C.1 for applicability.

Measurement is required at only one EUT supply voltage and frequency.

Applicable to ports listed above and intended to connect to cables longer than 3 m.

NOTE:

(1) The test result calculated as following:

Measurement Value = Reading Level + Correct Factor

Correct Factor = Insertion Loss + Cable Loss + Attenuator Factor(if use)

Margin Level = Measurement Value – Limit Value

4.3.2 MEASUREMENT INSTRUMENTS LIST

Item	Kind of Equipment	Manufacturer	Type No.	Serial No.	Calibrated until
1	EMI Test Receiver	R&S	ESCI	100382	Mar. 26, 2018
2	LISN	EMCO	3816/2	52765	Mar. 26, 2018
3	50Ω Terminator	SHX	TF2-3G-A	8122901	Mar. 26, 2018
4	TWO-LINE V-NETWORK	R&S	ENV216	101447	Mar. 26, 2018
5	Measurement Software	Farad	EZ-EMC Ver.NB-03A 1-01	N/A	N/A
6	Cable	N/A	RG223	12m	Oct. 19, 2018
7	ISN	FCC	FCC-TLISN -T2-02	20433	Jun. 20, 2018
8	ISN	Teseq GmbH	ISN T8	30833	Aug. 20, 2018

Remark: "N/A" denotes no model name, no serial No. or no calibration specified.
All calibration period of equipment list is one year.

4.3.3 TEST PROCEDURE

- a. The EUT was placed 0.8 meters from the horizontal ground plane with EUT being connected to the power mains through a line impedance stabilization network (LISN). All other support equipment powered from additional LISN(s). The LISN provide 50 Ohm/ 50uH of coupling impedance for the measuring instrument.
- b. Interconnecting cables that hang closer than 40 cm to the ground plane shall be folded back and forth in the center forming a bundle 30 to 40 cm long.
- c. I/O cables that are not connected to a peripheral shall be bundled in the center. The end of the cable may be terminated, if required, using the correct terminating impedance. The overall length shall not exceed 1 m.
- d. For the actual test configuration, please refer to the related Item –EUT Test Photos.
- e. **AAN, CP or CVP** at least 80 cm from nearest part of EUT chassis.

NOTE:

- f. The communication function of EUT was executed and AAN was connected between EUT and associated equipment and the AAN was connected directly to reference ground plane.
Measure the voltage at the measurement port of the AAN
Correct the measured voltage by adding the AAN voltage division factor
Compare the corrected voltage with the limit(**For AAN**)
- g Measure the current with a current probe and compare to the current limit(**For CP**)
- h The current shall be measured with the current probe and the results compared with the current limits.
The voltage measured shall be corrected at each frequency of interest as follows:
- if the current margin with respect to the current limit is ≤ 6 dB, the actual current margin shall be subtracted from the measured voltage;
-if the current margin with respect to the current limit is >6 dB, 6 dB shall be subtracted from the measured voltage.
The adjusted voltage shall be compared with the applicable voltage limit.
Both the measured current and the corrected voltage shall be below the applicable current and voltage limits at all frequencies for the EUT to be deemed compliant with this publication.(**For CVP**)

4.3.4 DEVIATION FROM TEST STANDARD

No deviation

4.3.5 TEST SETUP

a) Cable Type: Balanced Unscreened, Screened or Coaxial

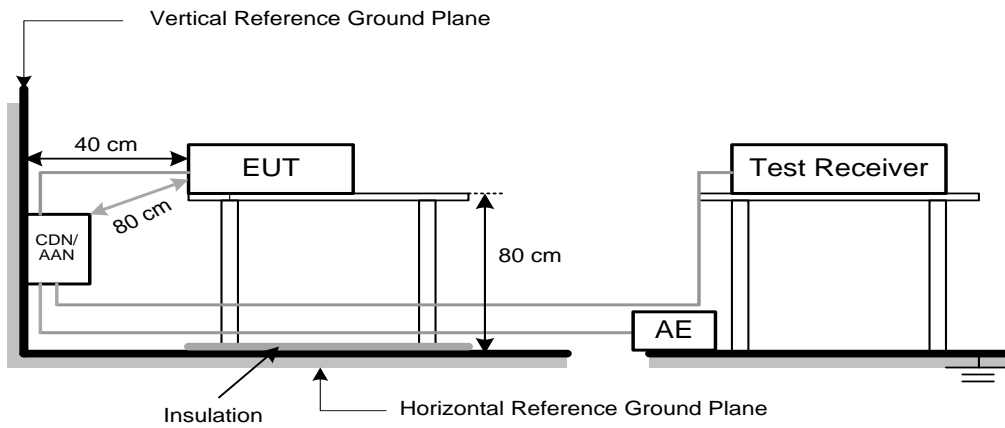

b) Cable Type: Screened or Coaxial

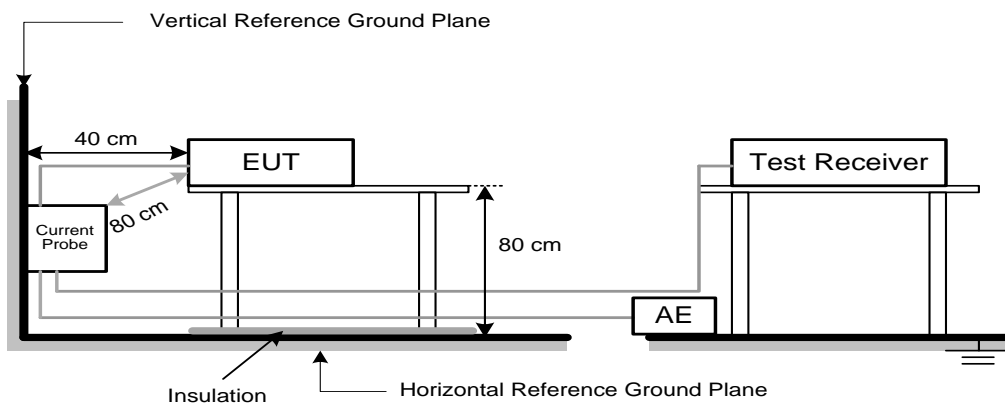

c) Cable Type: Balanced Unscreened, Unbalanced

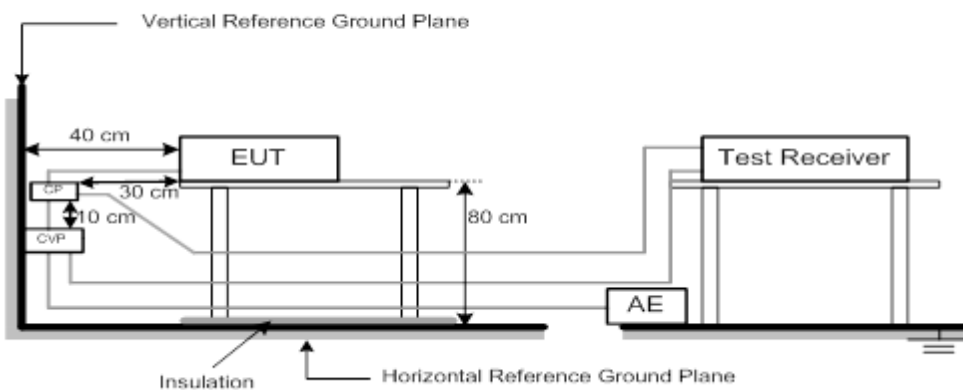

4.3.6 TEST RESULTS

EUT	IP Phone	Model Name	E6G
Temperature	25°C	Relative Humidity	53%
Test Voltage	DC 48V		
Test Mode	PC Port 1Gbps		
Note	PoE		
Test Engineer	Jason Yang		

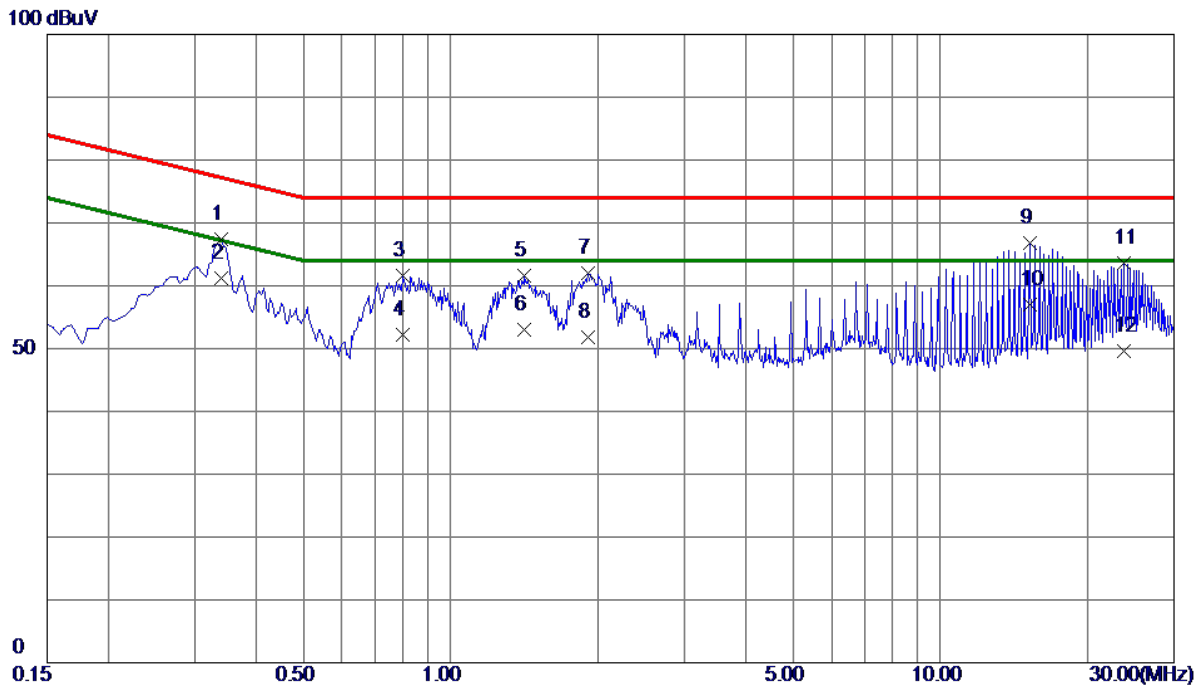

No.	Freq. MHz	Reading Level dBuV	Correct Factor dB	Measure ment dBuV	Limit dBuV	Margin dB	Detector
1	0.3390	57.17	10.20	67.37	77.23	-9.86	QP
2 *	0.3390	51.00	10.20	61.20	67.23	-6.03	AVG
3	0.7980	51.47	10.06	61.53	74.00	-12.47	QP
4	0.7980	42.10	10.06	52.16	64.00	-11.84	AVG
5	1.4144	51.55	10.01	61.56	74.00	-12.44	QP
6	1.4144	42.90	10.01	52.91	64.00	-11.09	AVG
7	1.9095	52.00	9.99	61.99	74.00	-12.01	QP
8	1.9095	41.80	9.99	51.79	64.00	-12.21	AVG
9	15.2205	56.55	10.16	66.71	74.00	-7.29	QP
10	15.2205	46.79	10.16	56.95	64.00	-7.05	AVG
11	23.7119	53.13	10.42	63.55	74.00	-10.45	QP
12	23.7119	39.20	10.42	49.62	64.00	-14.38	AVG

EUT	IP Phone	Model Name	E6G
Temperature	25°C	Relative Humidity	53%
Test Voltage	AC 230V/50Hz		
Test Mode	PC Port 1Gbps		
Note	Adapter		
Test Engineer	Jason Yang		

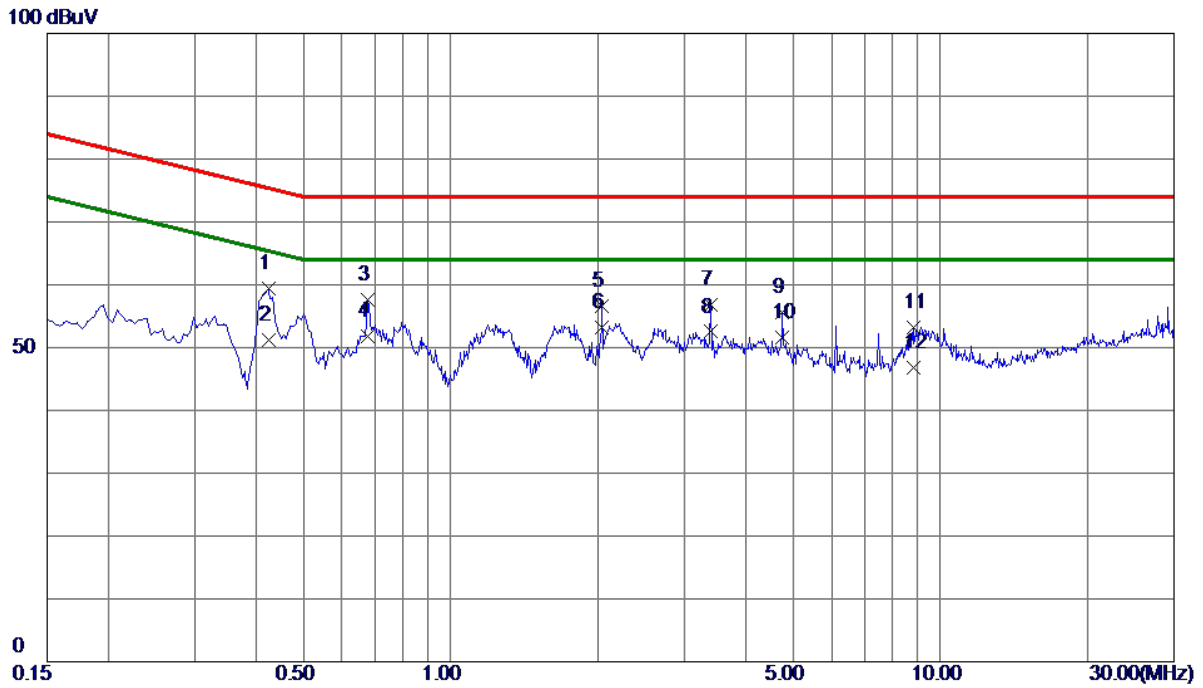

No.	Freq. MHz	Reading Level dBuV	Correct Factor dB	Measure ment dBuV	Limit dBuV	Margin dB	Detector
1	0.4245	49.18	10.16	59.34	75.36	-16.02	QP
2	0.4245	41.10	10.16	51.26	65.36	-14.10	AVG
3	0.6765	47.50	10.08	57.58	74.00	-16.42	QP
4	0.6765	41.71	10.08	51.79	64.00	-12.21	AVG
5	2.0355	46.65	9.99	56.64	74.00	-17.36	QP
6 *	2.0355	43.30	9.99	53.29	64.00	-10.71	AVG
7	3.3945	46.76	10.01	56.77	74.00	-17.23	QP
8	3.3945	42.49	10.01	52.50	64.00	-11.50	AVG
9	4.7490	45.68	10.01	55.69	74.00	-18.31	QP
10	4.7490	41.59	10.01	51.60	64.00	-12.40	AVG
11	8.8215	43.20	10.06	53.26	74.00	-20.74	QP
12	8.8215	36.70	10.06	46.76	64.00	-17.24	AVG

EUT	IP Phone	Model Name	E6G
Temperature	25°C	Relative Humidity	53%
Test Voltage	DC 48V		
Test Mode	PC Port 100Mbps		
Note	PoE		
Test Engineer	Jason Yang		

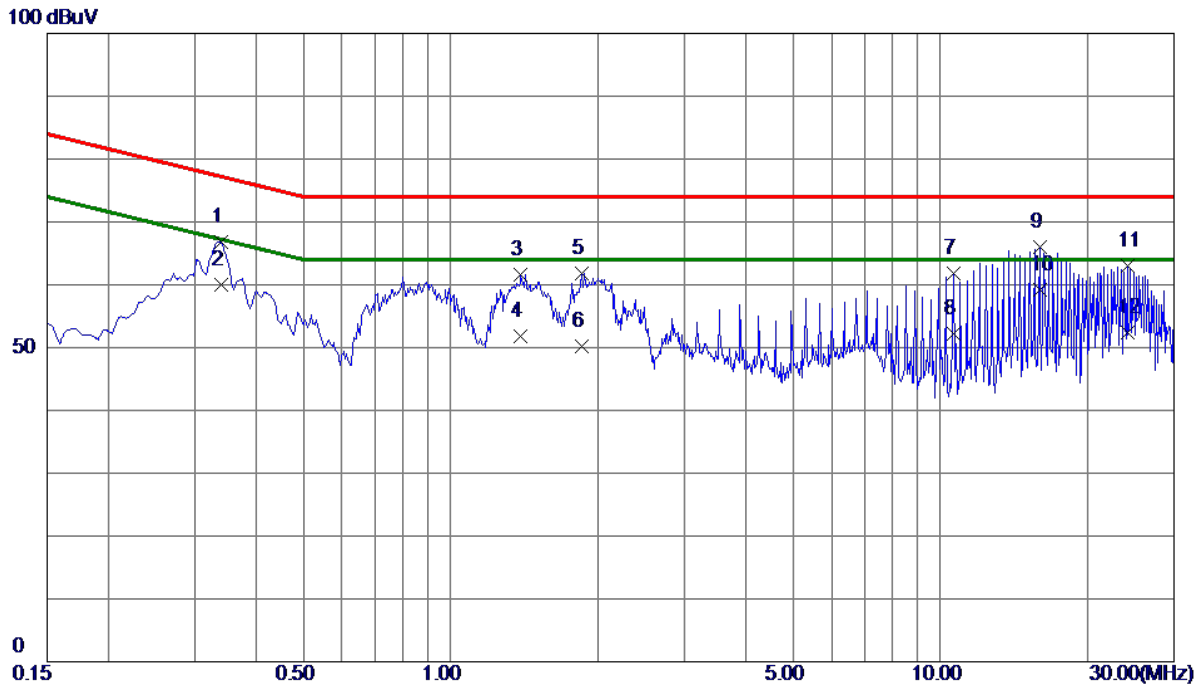

No.	Freq. MHz	Reading Level dBuV	Correct Factor dB	Measure ment dBuV	Limit dBuV	Margin dB	Detector
1	0.3390	56.64	10.20	66.84	77.23	-10.39	QP
2	0.3390	49.80	10.20	60.00	67.23	-7.23	AVG
3	1.3920	51.56	10.01	61.57	74.00	-12.43	QP
4	1.3920	41.70	10.01	51.71	64.00	-12.29	AVG
5	1.8555	51.86	9.99	61.85	74.00	-12.15	QP
6	1.8555	40.21	9.99	50.20	64.00	-13.80	AVG
7	10.6215	51.72	10.08	61.80	74.00	-12.20	QP
8	10.6215	42.20	10.08	52.28	64.00	-11.72	AVG
9	15.9405	55.91	10.18	66.09	74.00	-7.91	QP
10 *	15.9405	49.10	10.18	59.28	64.00	-4.72	AVG
11	24.0810	52.58	10.44	63.02	74.00	-10.98	QP
12	24.0810	41.89	10.44	52.33	64.00	-11.67	AVG

EUT	IP Phone	Model Name	E6G
Temperature	25°C	Relative Humidity	53%
Test Voltage	AC 230V/50Hz		
Test Mode	PC Port 100Mbps		
Note	Adapter		
Test Engineer	Jason Yang		

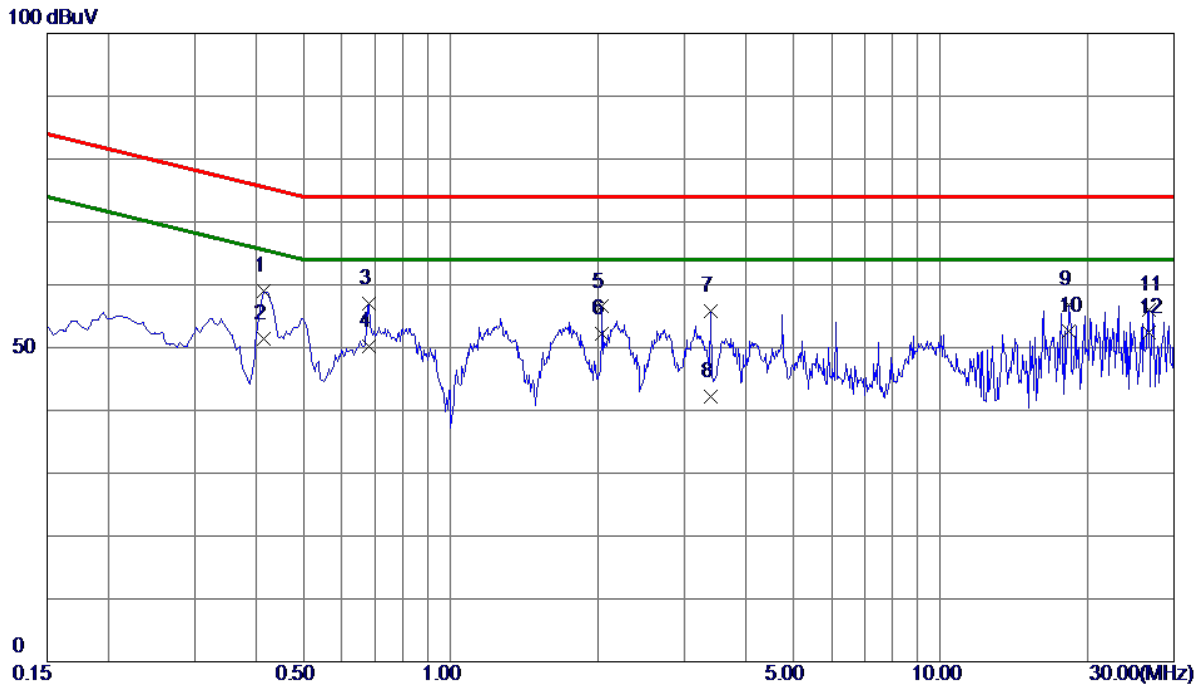

No.	Freq. MHz	Reading Level dBuV	Correct Factor dB	Measure ment dBuV	Limit dBuV	Margin dB	Detector
1	0.4155	48.78	10.16	58.94	75.54	-16.60	QP
2	0.4155	41.21	10.16	51.37	65.54	-14.17	AVG
3	0.6809	46.87	10.08	56.95	74.00	-17.05	QP
4	0.6809	40.21	10.08	50.29	64.00	-13.71	AVG
5	2.0355	46.51	9.99	56.50	74.00	-17.50	QP
6	2.0355	42.20	9.99	52.19	64.00	-11.81	AVG
7	3.3945	45.78	10.01	55.79	74.00	-18.21	QP
8	3.3945	32.19	10.01	42.20	64.00	-21.80	AVG
9	18.2445	46.50	10.24	56.74	74.00	-17.26	QP
10 *	18.2445	42.40	10.24	52.64	64.00	-11.36	AVG
11	26.6100	45.43	10.52	55.95	74.00	-18.05	QP
12	26.6100	41.90	10.52	52.42	64.00	-11.58	AVG

EUT	IP Phone	Model Name	E6G
Temperature	25°C	Relative Humidity	53%
Test Voltage	DC 48V		
Test Mode	PC Port 10Mbps		
Note	PoE		
Test Engineer	Jason Yang		

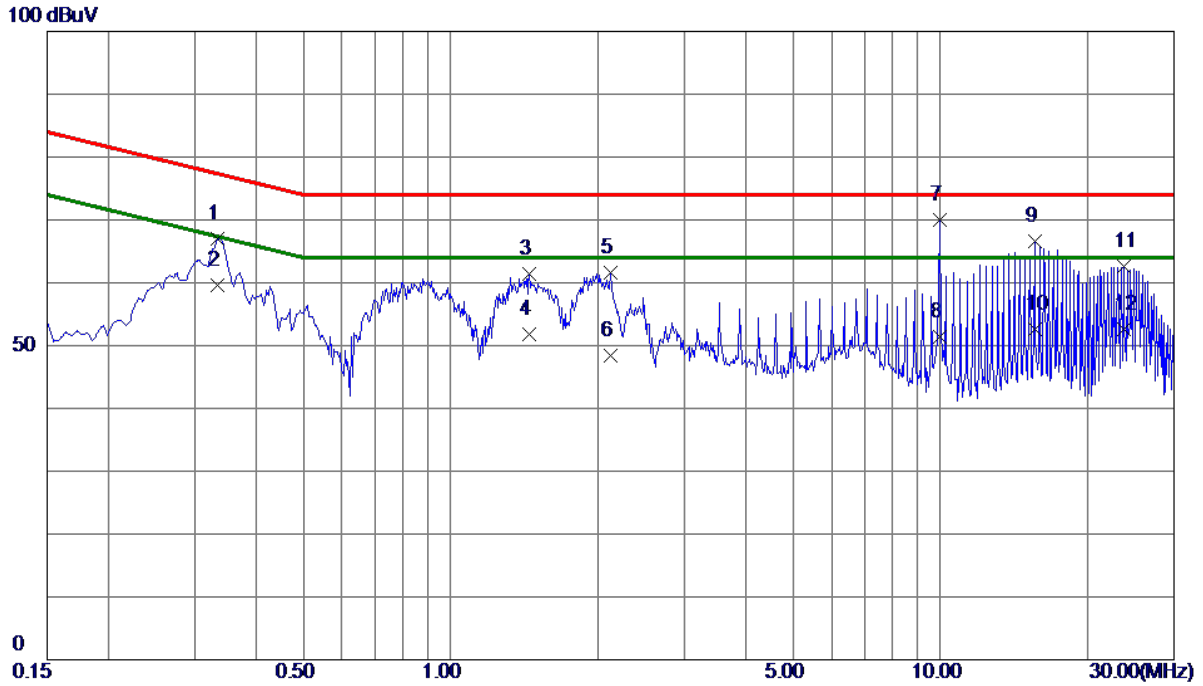

No.	Freq. MHz	Reading Level dBuV	Correct Factor dB	Measure ment dBuV	Limit dBuV	Margin dB	Detector
1	0.3345	56.89	10.20	67.09	77.34	-10.25	QP
2	0.3345	49.40	10.20	59.60	67.34	-7.74	AVG
3	1.4504	51.46	10.01	61.47	74.00	-12.53	QP
4	1.4504	41.80	10.01	51.81	64.00	-12.19	AVG
5	2.1164	51.52	9.99	61.51	74.00	-12.49	QP
6	2.1164	38.40	9.99	48.39	64.00	-15.61	AVG
7 *	9.9960	59.91	10.07	69.98	74.00	-4.02	QP
8	9.9960	41.40	10.07	51.47	64.00	-12.53	AVG
9	15.5760	56.38	10.17	66.55	74.00	-7.45	QP
10	15.5760	42.50	10.17	52.67	64.00	-11.33	AVG
11	23.7255	52.13	10.42	62.55	74.00	-11.45	QP
12	23.7255	42.20	10.42	52.62	64.00	-11.38	AVG

EUT	IP Phone	Model Name	E6G
Temperature	25°C	Relative Humidity	53%
Test Voltage	AC 230V/50Hz		
Test Mode	PC Port 10Mbps		
Note	Adapter		
Test Engineer	Jason Yang		

100 dBuV

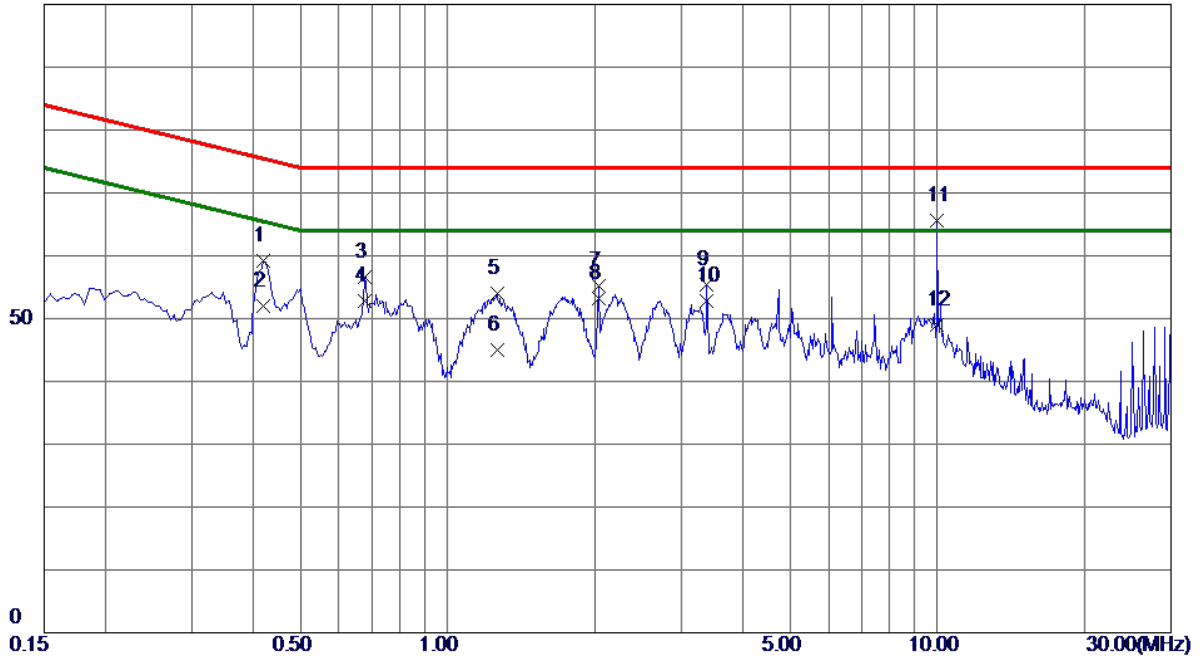

No.	Freq. MHz	Reading Level dBuV	Correct Factor dB	Measure ment dBuV	Limit dBuV	Margin dB	Detector
1	0.4200	49.00	10.16	59.16	75.45	-16.29	QP
2	0.4200	41.80	10.16	51.96	65.45	-13.49	AVG
3	0.6765	46.59	10.08	56.67	74.00	-17.33	QP
4	0.6765	42.71	10.08	52.79	64.00	-11.21	AVG
5	1.2615	44.00	10.01	54.01	74.00	-19.99	QP
6	1.2615	35.01	10.01	45.02	64.00	-18.98	AVG
7	2.0310	45.29	9.99	55.28	74.00	-18.72	QP
8	2.0310	43.20	9.99	53.19	64.00	-10.81	AVG
9	3.3855	45.36	10.01	55.37	74.00	-18.63	QP
10	3.3855	42.79	10.01	52.80	64.00	-11.20	AVG
11 *	9.9960	55.58	10.07	65.65	74.00	-8.35	QP
12	9.9960	39.00	10.07	49.07	64.00	-14.93	AVG

EUT	IP Phone	Model Name	E6G
Temperature	25°C	Relative Humidity	53%
Test Voltage	AC 230V/50Hz		
Test Mode	Internet Port 1Gbps		
Note	Adapter		
Test Engineer	Jason Yang		

100 dBuV

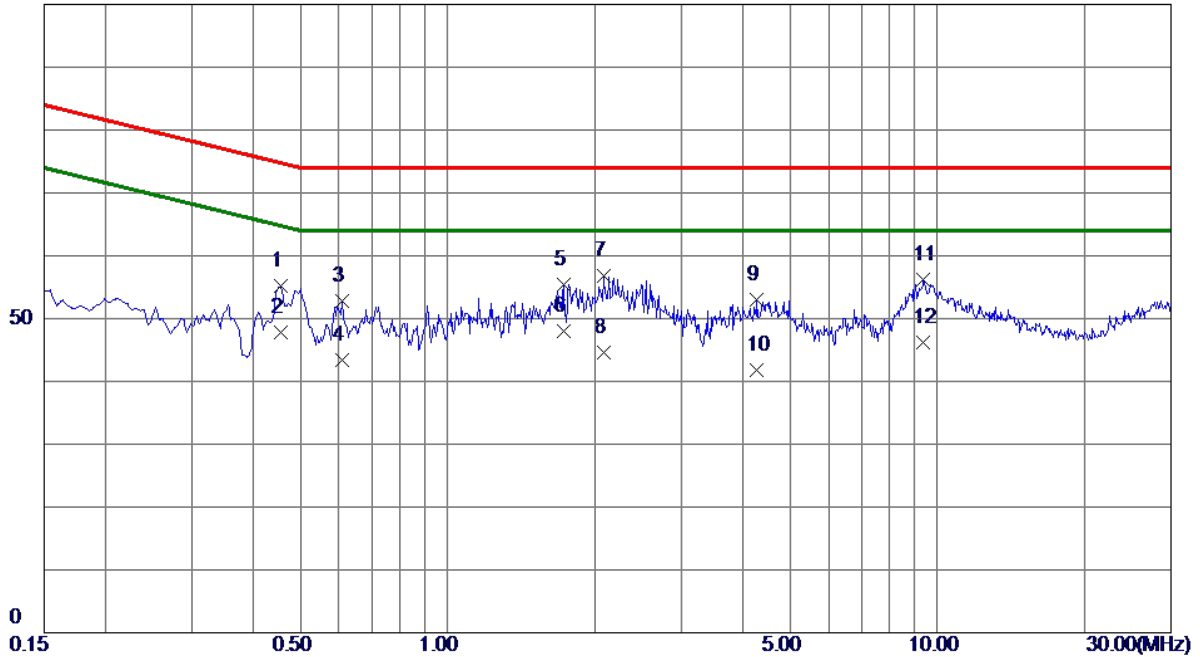

No.	Freq. MHz	Reading Level dBuV	Correct Factor dB	Measure ment dBuV	Limit dBuV	Margin dB	Detector
1	0.4560	45.13	10.14	55.27	74.77	-19.50	QP
2	0.4560	37.60	10.14	47.74	64.77	-17.03	AVG
3	0.6090	42.61	10.10	52.71	74.00	-21.29	QP
4	0.6090	33.39	10.10	43.49	64.00	-20.51	AVG
5	1.7250	45.38	10.00	55.38	74.00	-18.62	QP
6 *	1.7250	38.09	10.00	48.09	64.00	-15.91	AVG
7	2.0805	46.82	9.99	56.81	74.00	-17.19	QP
8	2.0805	34.60	9.99	44.59	64.00	-19.41	AVG
9	4.2765	42.97	10.01	52.98	74.00	-21.02	QP
10	4.2765	31.70	10.01	41.71	64.00	-22.29	AVG
11	9.3569	46.15	10.06	56.21	74.00	-17.79	QP
12	9.3569	36.20	10.06	46.26	64.00	-17.74	AVG

EUT	IP Phone	Model Name	E6G
Temperature	25°C	Relative Humidity	53%
Test Voltage	DC 48V		
Test Mode	Internet Port 100Mbps		
Note	PoE		
Test Engineer	Jason Yang		

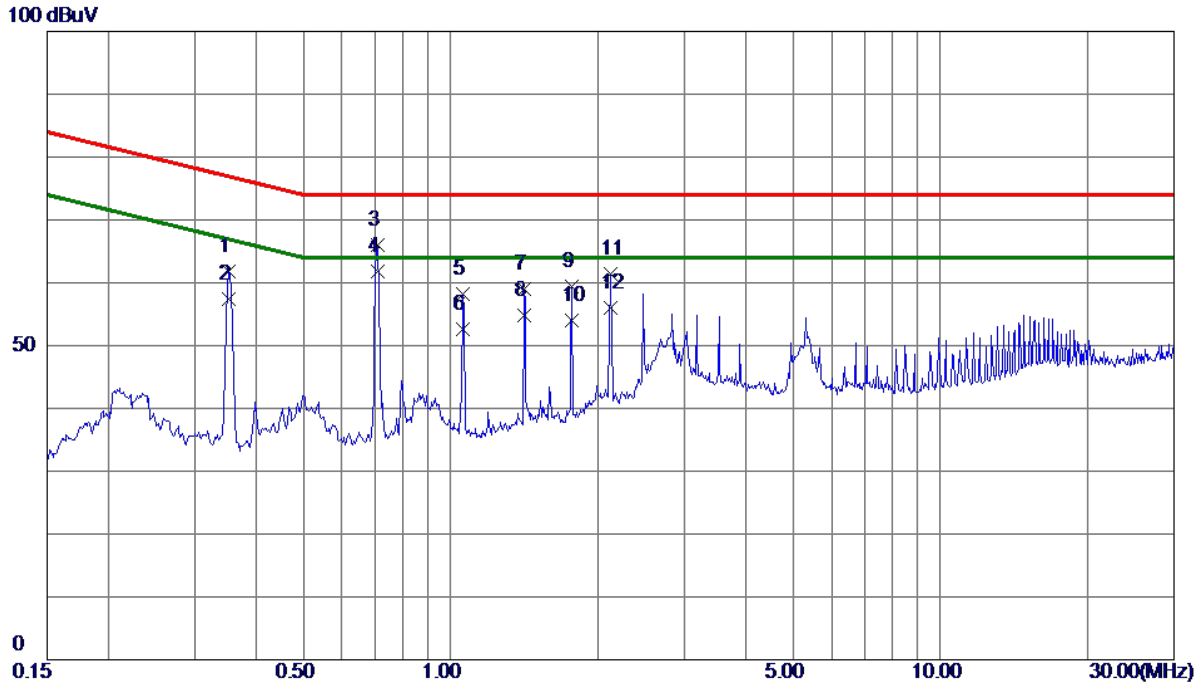

No.	Freq. MHz	Reading Level dBuV	Correct Factor dB	Measure ment dBuV	Limit dBuV	Margin dB	Detector
1	0.3523	52.02	9.81	61.83	76.91	-15.08	QP
2	0.3523	47.61	9.81	57.42	66.91	-9.49	AVG
3	0.7080	56.16	9.74	65.90	74.00	-8.10	QP
4 *	0.7080	52.10	9.74	61.84	64.00	-2.16	AVG
5	1.0611	48.52	9.72	58.24	74.00	-15.76	QP
6	1.0611	42.80	9.72	52.52	64.00	-11.48	AVG
7	1.4144	49.31	9.73	59.04	74.00	-14.96	QP
8	1.4144	45.10	9.73	54.83	64.00	-9.17	AVG
9	1.7677	49.69	9.74	59.43	74.00	-14.57	QP
10	1.7677	44.29	9.74	54.03	64.00	-9.97	AVG
11	2.1210	51.75	9.74	61.49	74.00	-12.51	QP
12	2.1210	46.21	9.74	55.95	64.00	-8.05	AVG

EUT	IP Phone	Model Name	E6G
Temperature	25°C	Relative Humidity	53%
Test Voltage	AC 230V/50Hz		
Test Mode	Internet Port 100Mbps		
Note	Adapter		
Test Engineer	Jason Yang		

100 dBuV

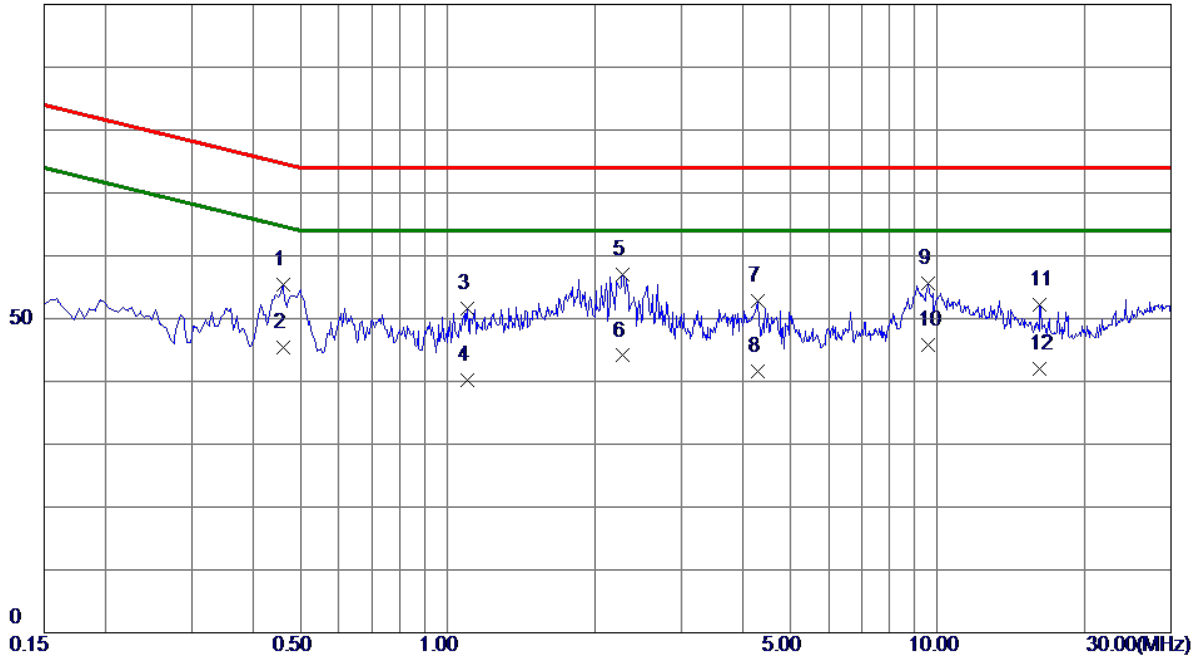

No.	Freq. MHz	Reading Level dBuV	Correct Factor dB	Measure ment dBuV	Limit dBuV	Margin dB	Detector
1	0.4605	45.22	10.14	55.36	74.68	-19.32	QP
2	0.4605	35.30	10.14	45.44	64.68	-19.24	AVG
3	1.0995	41.50	10.02	51.52	74.00	-22.48	QP
4	1.0995	30.10	10.02	40.12	64.00	-23.88	AVG
5 *	2.2785	47.05	9.99	57.04	74.00	-16.96	QP
6	2.2785	34.11	9.99	44.10	64.00	-19.90	AVG
7	4.2900	42.87	10.01	52.88	74.00	-21.12	QP
8	4.2900	31.60	10.01	41.61	64.00	-22.39	AVG
9	9.5685	45.56	10.06	55.62	74.00	-18.38	QP
10	9.5685	35.70	10.06	45.76	64.00	-18.24	AVG
11	16.1700	42.07	10.18	52.25	74.00	-21.75	QP
12	16.1700	31.90	10.18	42.08	64.00	-21.92	AVG

EUT	IP Phone	Model Name	E6G
Temperature	25°C	Relative Humidity	53%
Test Voltage	AC 230V/50Hz		
Test Mode	Internet Port 10Mbps		
Note	Adapter		
Test Engineer	Jason Yang		

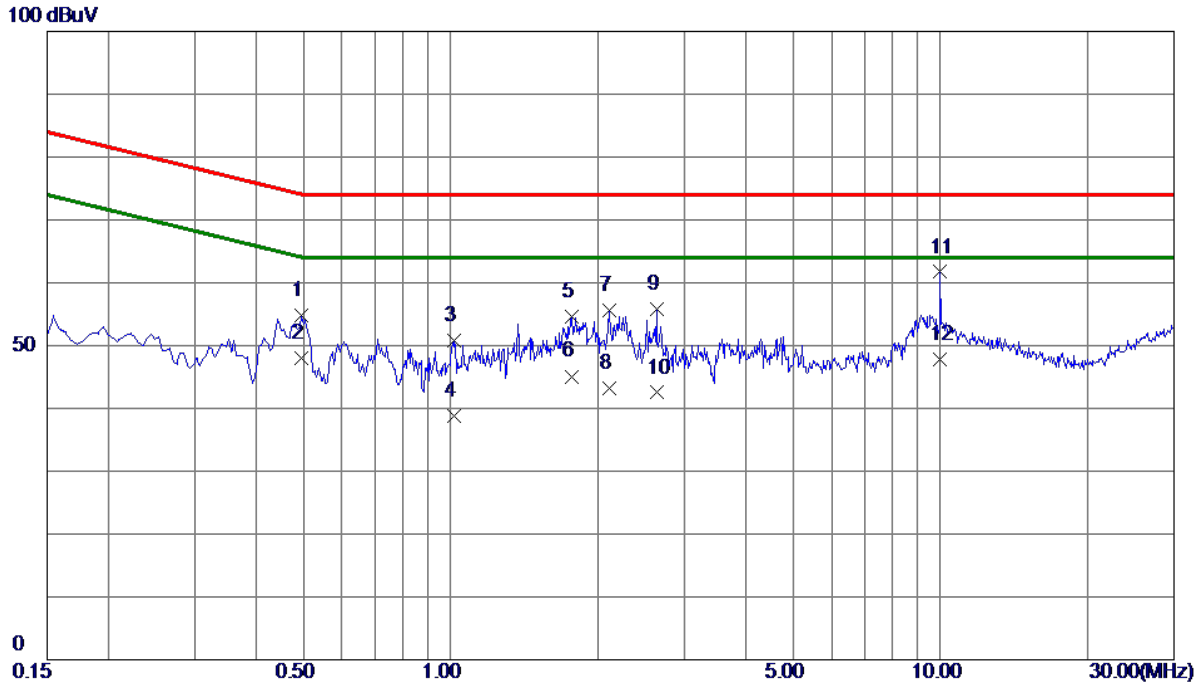

No.	Freq. MHz	Reading Level dBuV	Correct Factor dB	Measure ment dBuV	Limit dBuV	Margin dB	Detector
1	0.4965	44.62	10.12	54.74	74.06	-19.32	QP
2	0.4965	37.90	10.12	48.02	64.06	-16.04	AVG
3	1.0140	40.85	10.02	50.87	74.00	-23.13	QP
4	1.0140	28.80	10.02	38.82	64.00	-25.18	AVG
5	1.7655	44.64	10.00	54.64	74.00	-19.36	QP
6	1.7655	35.10	10.00	45.10	64.00	-18.90	AVG
7	2.1030	45.68	9.99	55.67	74.00	-18.33	QP
8	2.1030	33.20	9.99	43.19	64.00	-20.81	AVG
9	2.6340	45.83	10.00	55.83	74.00	-18.17	QP
10	2.6340	32.50	10.00	42.50	64.00	-21.50	AVG
11 *	10.0004	51.63	10.07	61.70	74.00	-12.30	QP
12	10.0004	37.80	10.07	47.87	64.00	-16.13	AVG

4.4 HARMONIC CURRENT EMISSIONS TEST

4.4.1 LIMITS

EN 61000-3-2						
Equipment Category	Harmonic Order n	Max. Permissible Harmonic Current A	Equipment Category	Harmonic Order n	Max. Permissible Harmonic Current A mA/w	
Class A	Odd Harmonics		Class D	Odd Harmonics only		
	3	2.30		3	2.30	3.4
	5	1.14		5	1.14	1.9
	7	0.77		7	0.77	1.0
	9	0.40		9	0.40	0.5
	11	0.33		11	0.33	0.35
	13	0.21		13	0.21	0.30
	15≤n≤39	0.15 x 15/n		15≤n≤39	0.15 x 15/n	3.85/n
	Even Harmonics					
	2	1.08				
	4	0.43				
	6	0.30				
	8≤n≤40	0.23 x 8/n				

4.4.2 MEASUREMENT INSTRUMENTS LIST

Item	Kind of Equipment	Manufacturer	Type No.	Serial No.	Calibrated until
1	Harmonics and Flicker Analyzer	California Instruments	PACS-1	72344	Aug. 15, 2018
2	3KVA AC Power source	California Instruments	3001ix	56309	Aug. 15, 2018
3	Measurement Software	California	CTS4.0 Version 4.9	N/A	N/A

Remark: "N/A" denotes no model name, no serial No. or no calibration specified.
All calibration period of equipment list is one year.

4.4.3 TEST PROCEDURE

- a. The EUT was placed on the top of a wooden table 0.8 meters above the ground and operated to produce the maximum harmonic components under normal operating conditions.
- b. The classification of EUT is according to of EN 61000-3-2. The EUT is classified as follows:
 - Class A: Balanced three-phase equipment, Household appliances excluding equipment as Class D, Tools excluding portable tools, Dimmers for incandescent lamps, audio equipment, equipment not specified in one of the three other classes.
 - Class B: Portable tools; Arc welding equipment which is not professional equipment.
 - Class C: Lighting equipment.
 - Class D: Equipment having a specified power less than or equal to 600 W of the following types: Personal computers and personal computer monitors and television receivers.
- c. The correspondent test program of test instrument to measure the current harmonics emanated from EUT is chosen. The measure time shall be not less than the time necessary for the EUT to be exercised.

4.4.4 DEVIATION FROM TEST STANDARD

No deviation

4.4.5 TEST SETUP

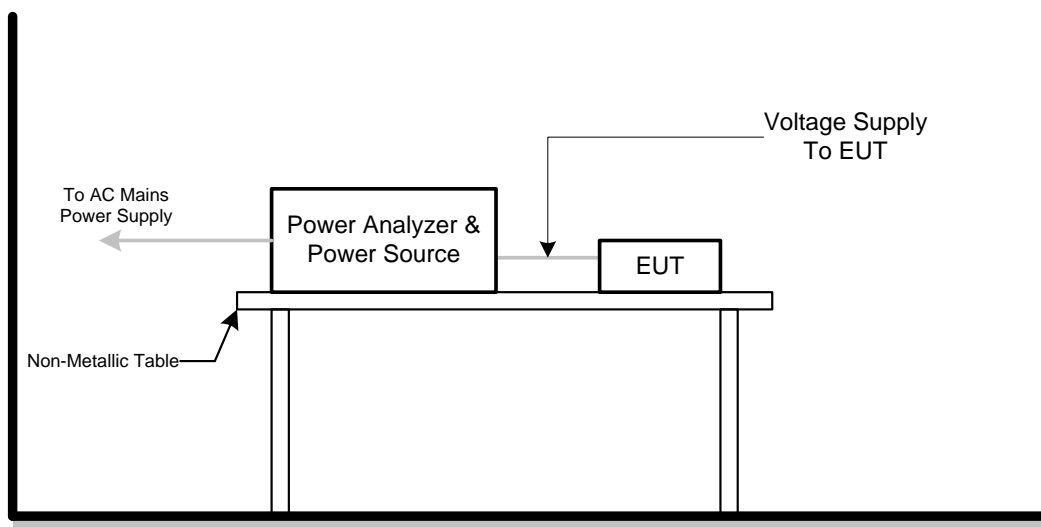

4.4.6 TEST RESULTS

Harmonic - Class A			
EUT	IP Phone	Model Name	E6G
Temperature	25°C	Relative Humidity	55%
Test Voltage	AC 230V/50Hz		
Test Mode	Handfree		

Current & voltage waveforms

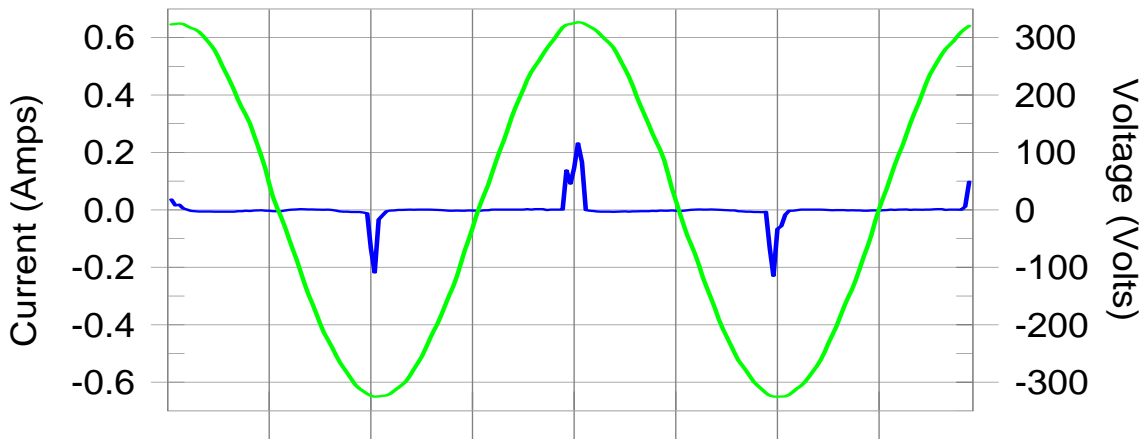

Harmonics and Class A limit line European Limits

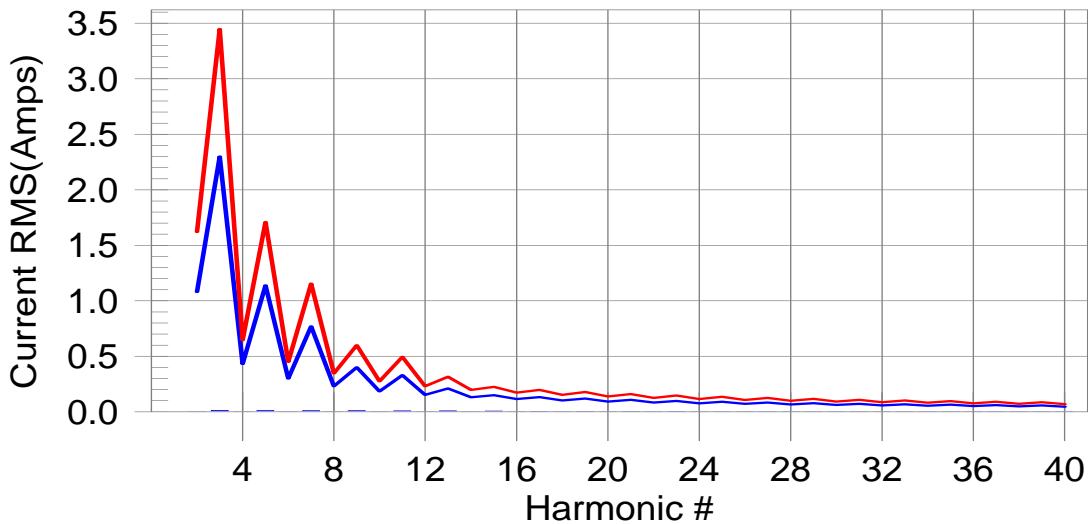

Test result: Pass Worst harmonic was #15 with 3.0% of the limit.

Current Test Result Summary (Run time)			
EUT	IP Phone	Model Name	E6G
Temperature	25°C	Relative Humidity	55%
Test Voltage	AC 230V/50Hz		
Test Mode	Handfree		

Highest parameter values during test:

V_RMS (Volts): 230.00	Frequency(Hz): 50.00
I_Peak (Amps): 0.439	I_RMS (Amps): 0.037
I_Fund (Amps): 0.013	Crest Factor: 12.165
Power (Watts): 2.9	Power Factor: 0.371

Harm#	Harms(avg)	100%Limit	%of Limit	Harms(max)	155%Limit	%of Limit	Status
2	0.001	1.080	N/A	0.002	1.620	N/A	Pass
3	0.011	2.300	0.5	0.013	3.450	0.4	Pass
4	0.001	0.430	N/A	0.002	0.645	N/A	Pass
5	0.011	1.140	1.0	0.012	1.710	0.7	Pass
6	0.001	0.300	N/A	0.002	0.450	N/A	Pass
7	0.010	0.770	1.3	0.011	1.155	0.9	Pass
8	0.001	0.230	N/A	0.001	0.345	N/A	Pass
9	0.009	0.400	2.3	0.010	0.600	1.6	Pass
10	0.001	0.184	N/A	0.002	0.276	N/A	Pass
11	0.008	0.330	2.5	0.009	0.495	1.8	Pass
12	0.001	0.153	N/A	0.001	0.230	N/A	Pass
13	0.007	0.210	3.5	0.008	0.315	2.5	Pass
14	0.001	0.131	N/A	0.001	0.197	N/A	Pass
15	0.006	0.150	4.2	0.007	0.225	3.0	Pass
16	0.001	0.115	N/A	0.001	0.173	N/A	Pass
17	0.005	0.132	3.9	0.006	0.198	2.9	Pass
18	0.001	0.102	N/A	0.001	0.153	N/A	Pass
19	0.004	0.118	N/A	0.005	0.178	N/A	Pass
20	0.001	0.092	N/A	0.001	0.138	N/A	Pass
21	0.003	0.107	N/A	0.004	0.161	N/A	Pass
22	0.001	0.084	N/A	0.001	0.125	N/A	Pass
23	0.002	0.098	N/A	0.003	0.147	N/A	Pass
24	0.001	0.077	N/A	0.001	0.115	N/A	Pass
25	0.002	0.090	N/A	0.002	0.135	N/A	Pass
26	0.001	0.071	N/A	0.001	0.107	N/A	Pass
27	0.001	0.083	N/A	0.001	0.125	N/A	Pass
28	0.001	0.066	N/A	0.001	0.099	N/A	Pass
29	0.001	0.078	N/A	0.001	0.116	N/A	Pass
30	0.001	0.061	N/A	0.001	0.092	N/A	Pass
31	0.000	0.073	N/A	0.001	0.109	N/A	Pass
32	0.000	0.058	N/A	0.001	0.086	N/A	Pass
33	0.000	0.068	N/A	0.000	0.102	N/A	Pass
34	0.000	0.054	N/A	0.001	0.081	N/A	Pass
35	0.000	0.064	N/A	0.000	0.096	N/A	Pass
36	0.000	0.051	N/A	0.000	0.077	N/A	Pass
37	0.000	0.061	N/A	0.000	0.091	N/A	Pass
38	0.000	0.048	N/A	0.000	0.073	N/A	Pass
39	0.000	0.058	N/A	0.000	0.087	N/A	Pass
40	0.000	0.046	N/A	0.000	0.069	N/A	Pass

Voltage Source Verification Data (Run time)			
EUT	IP Phone	Model Name	E6G
Temperature	25°C	Relative Humidity	55%
Test Voltage	AC 230V/50Hz		
Test Mode	Handfree		

Highest parameter values during test:

Voltage (Vrms):230.00	Frequency(Hz): 50.00
I_Peak (Amps):0.439	I_RMS (Amps): 0.037
I_Fund (Amps):0.013	Crest Factor: 12.165
Power (Watts): 2.9	Power Factor: 0.371

Harm#	Harmonics V-rms	Limit V-rms	% of Limit	Status
2	0.126	0.460	27.49	OK
3	0.230	2.069	11.12	OK
4	0.086	0.460	18.66	OK
5	0.215	0.920	23.37	OK
6	0.069	0.460	14.96	OK
7	0.067	0.690	9.67	OK
8	0.178	0.460	38.74	OK
9	0.314	0.460	68.31	OK
10	0.090	0.460	19.58	OK
11	0.124	0.230	53.90	OK
12	0.099	0.230	42.85	OK
13	0.081	0.230	35.05	OK
14	0.048	0.230	20.88	OK
15	0.060	0.230	26.25	OK
16	0.035	0.230	15.41	OK
17	0.025	0.230	10.66	OK
18	0.015	0.230	6.69	OK
19	0.026	0.230	11.45	OK
20	0.014	0.230	6.11	OK
21	0.013	0.230	5.52	OK
22	0.015	0.230	6.56	OK
23	0.016	0.230	7.10	OK
24	0.007	0.230	3.22	OK
25	0.009	0.230	4.11	OK
26	0.006	0.230	2.70	OK
27	0.009	0.230	4.07	OK
28	0.009	0.230	3.81	OK
29	0.007	0.230	3.03	OK
30	0.007	0.230	3.10	OK
31	0.007	0.230	3.22	OK
32	0.007	0.230	3.23	OK
33	0.008	0.230	3.39	OK
34	0.006	0.230	2.40	OK
35	0.006	0.230	2.45	OK
36	0.005	0.230	2.22	OK
37	0.005	0.230	2.32	OK
38	0.004	0.230	1.85	OK
39	0.005	0.230	2.24	OK
40	0.006	0.230	2.79	OK

4.5 VOLTAGE CHANGES, VOLTAGE FLUCTUATIONS AND FLICKER TEST

4.5.1 LIMITS

Tests	Limits	Descriptions
	EN 61000-3-3	
Pst	≤ 1.0 , $T_p = 10$ min.	Short Term Flicker Indicator
Plt	≤ 0.65 , $T_p = 2$ hr.	Long Term Flicker Indicator
dc	$\leq 3.3\%$	Relative Steady-State V-Chang
dmax	$\leq 4\%$	Maximum Relative V-change
d (t)	$\leq 3.3\%$ for > 500 ms	Relative V-change characteristic

4.5.2 MEASUREMENT INSTRUMENTS LIST

Item	Kind of Equipment	Manufacturer	Type No.	Serial No.	Calibrated until
1	Harmonics and Flicker Analyzer	California Instruments	PACS-1	72344	Aug. 15, 2018
2	3KVA AC Power source	California Instruments	3001ix	56309	Aug. 15, 2018
3	Measurement Software	California	CTS4.0 Version 4.9	N/A	N/A

Remark: "N/A" denotes no model name, no serial No. or no calibration specified.

All calibration period of equipment list is one year.

4.5.3 TEST PROCEDURE

- Tests was performed according to the Test Conditions/Assessment of Voltage Fluctuations specified in EN 61000-3-3 depend on which standard adopted for compliance measurement.
- All types of harmonic current and/or voltage fluctuation in this report are assessed by direct measurement using flicker-meter.

4.5.4 DEVIATION FROM TEST STANDARD

No deviation

4.5.5 TESTSETUP

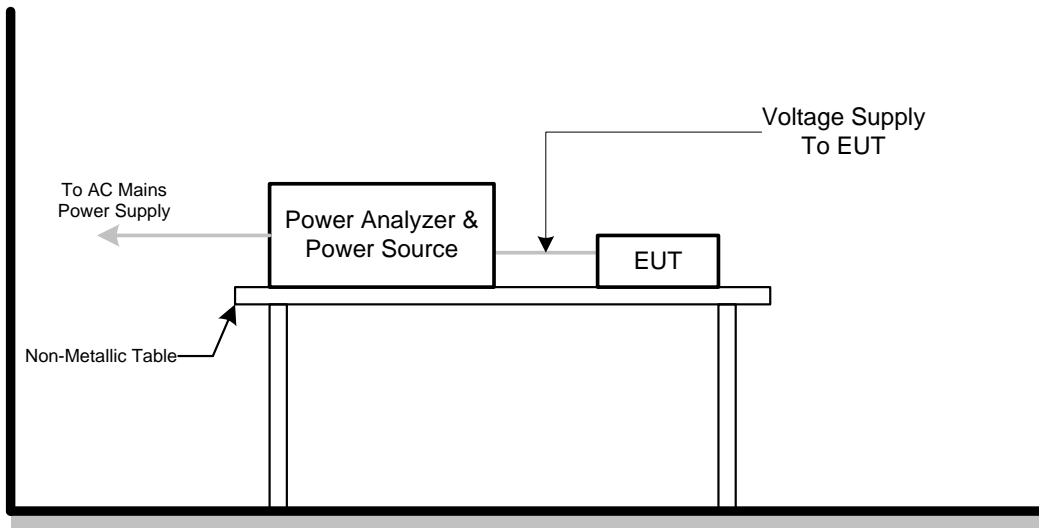

4.5.6 TEST RESULTS

EUT	IP Phone	Model Name	E6G
Temperature	25°C	Relative Humidity	55%
Test Voltage	AC 230V/50Hz		
Test Mode	Handfree		

Psti and limit line

European Limits

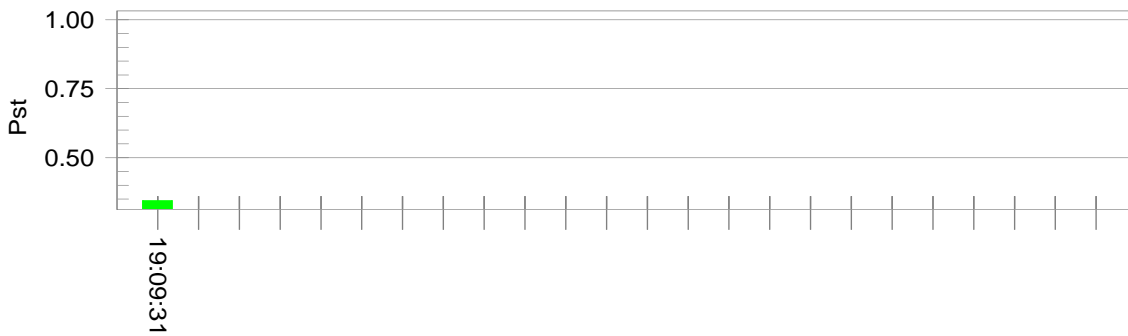

Plt and limit line

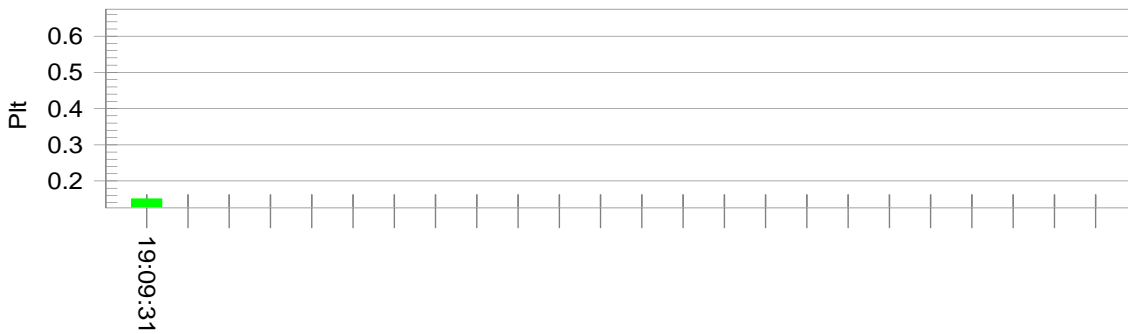

Parameter values recorded during the test:

Vrms at the end of test (Volt):229.86

Highest dt (%): -0.67

T-max (mS): 0

Highest dc (%): -0.20

Highest dmax (%): 0.52

Highest Pst (10 min. period): 0.345

Highest Plt (2 hr. period): 0.151

Test limit (%): N/A N/A

Test limit (mS): 500.0 Pass

Test limit (%): 3.30 Pass

Test limit (%): 4.00 Pass

Test limit: 1.000 Pass

Test limit: 0.650 Pass

5. EMC IMMUNITY TEST

5.1 STANDARD COMPLIANCE/SEVERITY LEVEL/CRITERIA

Tests Standard No.	Test Specification Level / Test Mode	Test Ports	Criteria
Electrostatic discharge EN 61000-4-2 (ESD)	±8 kV air discharge ±4 kV contact discharge (Direct Mode)	Enclosure	B
	±4kV HCP discharge ±4kV VCP discharge (Indirect Mode)	Enclosure	B
Radiated, radio-frequency, electromagnetic field immunity EN 61000-4-3 (RS)	80 MHz to 1000 MHz 3V/m(unmodulated, r.m.s), 1 kHz, 80%, AM modulated	Enclosure	A
Electrical fast transient/burst immunity EN 61000-4-4 (EFT/Burst)	±0.5kV(peak) 5/50ns Tr/Th 5kHz Repetition Frequency (100kHz Repetition Frequency for xDSL equipment)	Signal ports and telecommunication ports (Only applicable to cable length>3 m)	B
	±0.5kV(peak) 5/50ns Tr/Th 5kHz Repetition Frequency	DC Power Ports	B
	±1 kV(peak) 5/50ns Tr/Th 5kHz Repetition Frequency	AC Power Ports	B
Surge immunity EN 61000-4-5 (Surges)	±1 kV(peak) 10/700 Tr/Th μs(NOTE) (without primary protection)	Signal ports and telecommunication ports (applicable only to ports connect directly to outdoor cables)	C
	±4 kV(peak) 10/700 Tr/Th μs(NOTE) (with primary protectors fitted)		C
	±0.5 kV(peak) 1.2/50(8/20) Tr/Th μs	DC Power Ports (applicable only to ports connect directly to outdoor cables)	B
	±1 kV(peak) 1.2/50(8/20) Tr/Th μs (line to line)	AC Power Ports	B
	±2 kV(peak) 1.2/50(8/20) Tr/Th μs (line to earth or ground)		B

Immunity to conducted disturbances, induced by radio-frequency fields EN 61000-4-6 (Injected Current)	0.15 MHz to 80 MHz 3V(unmodulated, r.m.s), 1kHz 80%, AM 150Ω source impedance	Signal ports and telecommunication ports (Only applicable to cable length>3 m)	A
	0.15 MHz to 80 MHz 3V(unmodulated, r.m.s), 1kHz 80%, AM 150Ω source impedance	DC Power Ports	A
	0.15 MHz to 80 MHz 3V(unmodulated, r.m.s), 1kHz 80%, AM 150Ω source impedance	AC Power Ports	A
Power frequency magnetic field immunity EN 61000-4-8 (PFMF)	50 Hz or 60Hz, 1A/m(r.m.s) μs	Enclosure	A
Voltage dips, short interruptions and voltage variations immunity EN 61000-4-11 (Voltage Interruption/Dips)	Voltage reduction > 95% 0.5 period Voltage reduction 30% 25 periods Voltage reduction > 95% 250 periods	AC Power Ports	B C C

Note.

Where the coupling network for the 10/700 μs waveform affects the functioning of high speed data ports, the test shall be carried out using a 1,2/50 (8/20) μs waveform and appropriate coupling network.

5.2 GENERAL PERFORMANCE CRITERIA

According to **EN55024** standard, the general performance criteria as following:

<p>Criterion A</p>	<p>The equipment shall continue to operate as intended without operator intervention. No degradation of performance or loss of function is allowed below a performance level specified by the manufacturer when the equipment is used as intended. The performance level may be replaced by a permissible loss of performance.</p> <p>If the minimum performance level or the permissible performance loss is not specified by the manufacturer, then either of these may be derived from the product description and documentation, and by what the user product description and documentation, and by what the user may reasonably expect from the equipment if used as intended.</p>
<p>Criterion B</p>	<p>After the test, the equipment shall continue to operate as intended without operator intervention. No degradation of performance or loss of function is allowed, after the application of the phenomenon below a performance level specified by the manufacturer, when the equipment is used as intended. The performance level may be replaced by a permissible loss of performance.</p> <p>During the test, degradation of performance is allowed. However, no change of operating state if stored data allowed to persist after the test. If the minimum performance level (or the permissible performance loss) is not specified by the manufacturer, then either of these may be derived from the product description and documentation, and by what the user may reasonably expect from the equipment if used as intended.</p>
<p>Criterion C</p>	<p>Loss of function is allowed, provided the function is self-recoverable, or can be restored by the operation of the controls by the user in accordance with the manufacturer's instructions.</p> <p>Functions, and/or information stored in non-volatile memory, or protected by a battery backup, shall not be lost.</p>

5.3 ELECTROSTATIC DISCHARGE IMMUNITY TEST (ESD)

5.3.1 TEST SPECIFICATION

Basic Standard	EN 61000-4-2
Discharge Impedance	330 ohm / 150 pF
Required Performance	B
Discharge Voltage	Air Discharge: ± 2 kV, ± 4 kV, ± 8 kV (Direct) Contact Discharge: ± 2 kV, ± 4 kV (Indirect)
Polarity	Positive & Negative
Number of Discharge	Air Discharge: min. 20 times at each test point Contact Discharge: min. 200 times in total
Discharge Mode	Single Discharge
Discharge Period	1 second minimum

5.3.2 MEASUREMENT INSTRUMENTS

Item	Kind of Equipment	Manufacturer	Type No.	Serial No.	Calibrated until
1	ESD Generator	TESEQ AG	NSG 437	450	Nov. 01, 2018

Remark: "N/A" denotes no model name, no serial No. or no calibration specified.

All calibration period of equipment list is one year.

5.3.3 TEST PROCEDURE

The test generator necessary to perform direct and indirect application of discharges to the EUT in the following manner:

- a. Contact discharge was applied to conductive surfaces (Direct) and coupling planes (Indirect) of the EUT.

During the test, it was performed with single discharges. For the single discharge time between successive single discharges was at least 1 second. The EUT shall be exposed to at least 200 discharges, 100 each at negative and positive polarity, at a minimum of four test points. One of the test points shall be subjected to at least 50 indirect discharges to the center of the front edge of the horizontal coupling plane. The remaining three test points shall each receive at least 50 direct contact discharges.

If no direct contact test points are available, then at least 200 indirect discharges shall be applied in the indirect mode. Test shall be performed at a maximum repetition rate of one discharge per second.

Vertical Coupling Plane (VCP):

The coupling plane, of dimensions 0.5m x 0.5m, is placed parallel to, and positioned at a distance 0.1m from, the EUT, with the Discharge Electrode touching the coupling plane.

The four faces of the EUT will be performed with electrostatic discharge.

Horizontal Coupling Plane (HCP):

The coupling plane is placed under to the EUT. The generator shall be positioned vertically at a distance of 0.1m from the EUT, with the Discharge Electrode touching the coupling plane.

The four faces of the EUT will be performed with electrostatic discharge.

- b. Air discharges at insulation surfaces of the EUT.

It was at least ten single discharges with positive and negative at the same selected point.

5.3.4 DEVIATION FROM TEST STANDARD

No deviation

5.3.5 TEST SETUP

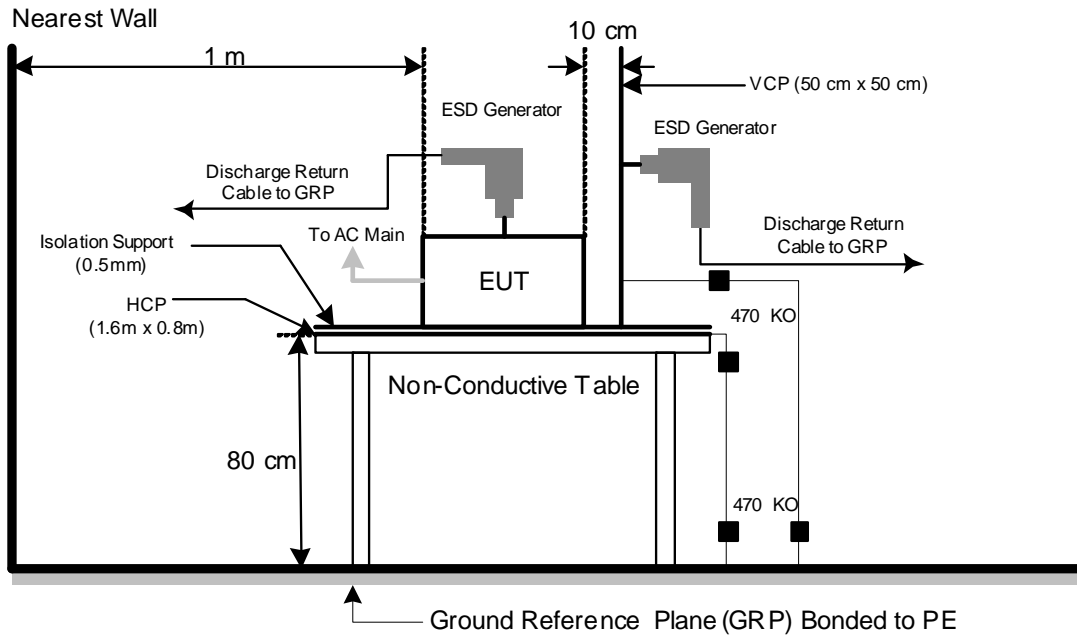

Note:

TABLE-TOP EQUIPMENT

The configuration consisted of a wooden table 0.8 meters high standing on the Ground Reference Plane. The GRP consisted of a sheet of aluminum at least 0.25mm thick, and 2.5 meters square connected to the protective grounding system. A Horizontal Coupling Plane (1.6m x 0.8m) was placed on the table and attached to the GRP by means of a cable with 940k total impedance. The equipment under test was installed in a representative system as described in EN 61000-4-2, and its cables were placed on the HCP and isolated by an insulating support of 0.5mm thickness. A distance of 1-meter minimum was provided between the EUT and the walls of the laboratory and any other metallic structure.

FLOOR-STANDING EQUIPMENT

The equipment under test was installed in a representative system as described in EN 61000-4-2, and its cables were isolated from the Ground Reference Plane by an insulating support of 0.1-meter thickness. The GRP consisted of a sheet of aluminum that is at least 0.25mm thick, and 2.5meters square connected to the protective grounding system and extended at least 0.5 meters from the EUT on all sides.

5.3.6 TEST RESULTS

EUT	IP Phone	Model Name	E6G
Temperature	25°C	Relative Humidity	43%
Test Voltage	AC 230V/50Hz	Pressure	1010hPa
Test Mode	Handfree,Handset,Headphone		

Mode	Air Discharge								Contact Discharge					
	2kV		4kV		8kV		- kV		2kV		4kV		- kV	
Location	P	N	P	N	P	N	P	N	P	N	P	N	P	N
1	A	A	A	A	A	A	-	-	-	-	-	-	-	-
2	A	A	A	A	A	A	-	-	-	-	-	-	-	-
3	A	A	A	A	A	A	-	-	-	-	-	-	-	-
4	A	A	A	A	A	A	-	-	-	-	-	-	-	-
5	A	A	A	A	A	A	-	-	-	-	-	-	-	-
6	A	A	A	A	A	A	-	-	-	-	-	-	-	-
7	A	A	A	A	A	A	-	-	-	-	-	-	-	-
8	A	A	A	A	A	A	-	-	-	-	-	-	-	-
Criteria	B						-		B				-	
Result	A						-		N/A				-	
Judgment	PASS						-		N/A				-	

Mode	HCP Contact Discharge						VCP Contact Discharge							
	2kV		4kV		- kV		2kV		4kV		- kV			
Location	P	N	P	N	P	N	P	N	P	N	P	N		
1	A	A	A	A	-	-	A	A	A	A	-	-		
2	A	A	A	A	-	-	A	A	A	A	-	-		
3	A	A	A	A	-	-	A	A	A	A	-	-		
4	A	A	A	A	-	-	A	A	A	A	-	-		
Criteria	B				-		B				-			
Result	A				-		A				-			
Judgment	PASS						-		PASS				-	

Note:

- 1) P/N denotes the Positive/Negative polarity of the output voltage.
- 2) Test condition:
 Direct/Indirect(HCP/VCP) discharges: Minimum 50 times (Positive/Negative) at eachpoint.
 Air discharges: Minimum 20 times (Positive/Negative) at each point.
- 3) Test location(s) in which discharge (Air and contact discharge) to be applied illustrated by photos shown in next page(s)
- 4) The Indirect (HCP/VCP) discharges description of test point as following:
 1.left side; 2.right side; 3.front side; 4.rear side.
- 5) N/A - denotes test is not applicable in this test report
- 6) Criterion A: No observation of any performance degradation.
- 7) Criterion B: Some degradation of performance is observed but the equipment continues to operate as intended.
- 8) Criterion C: Loss of functionality, but self-recoverable by user, without loss of information or settings.

PHOTO(S) SHOWN THE LOCATION(S) OF ESD EVALUATED

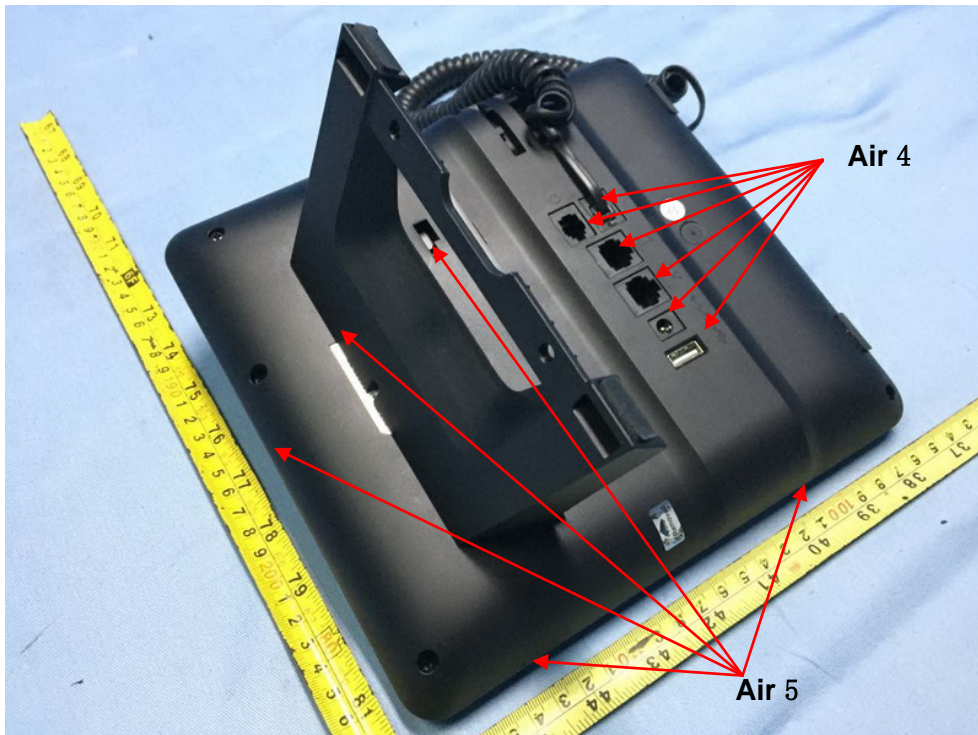
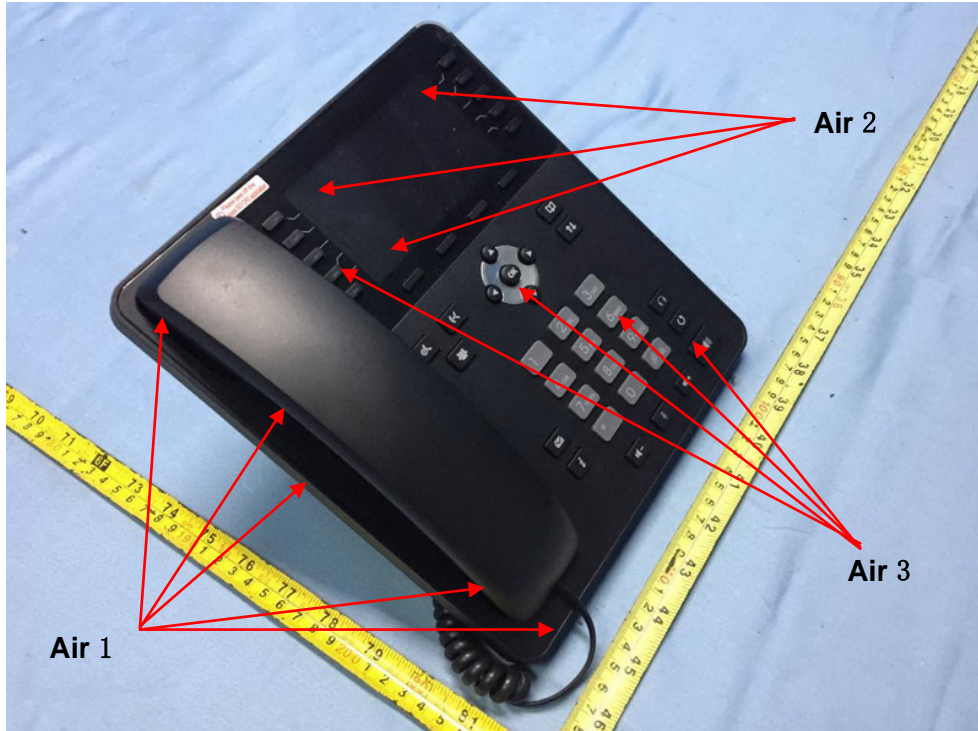

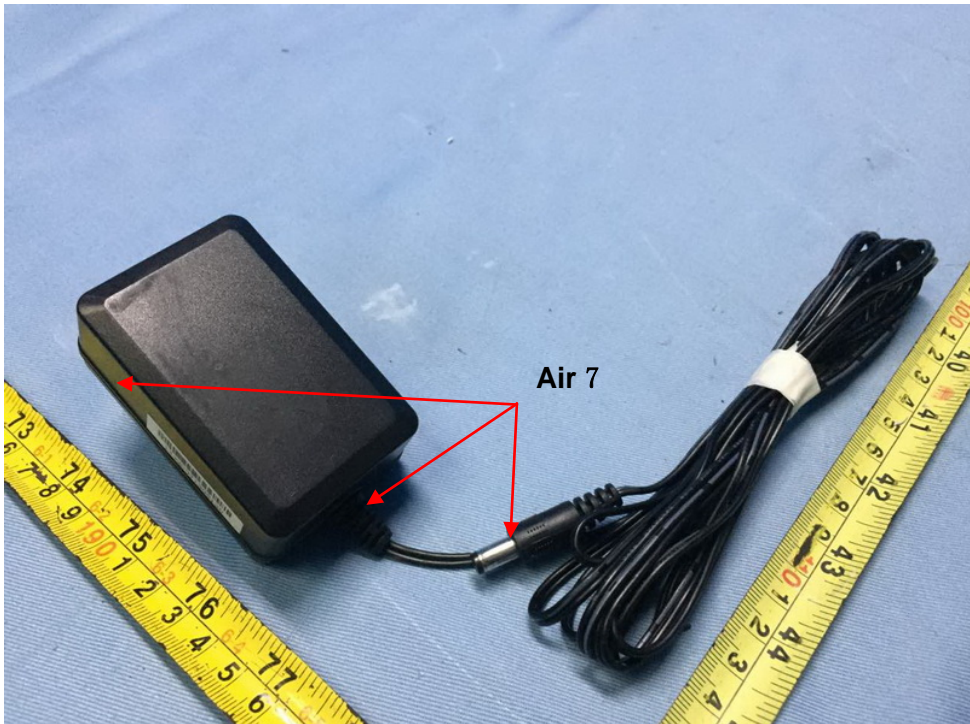

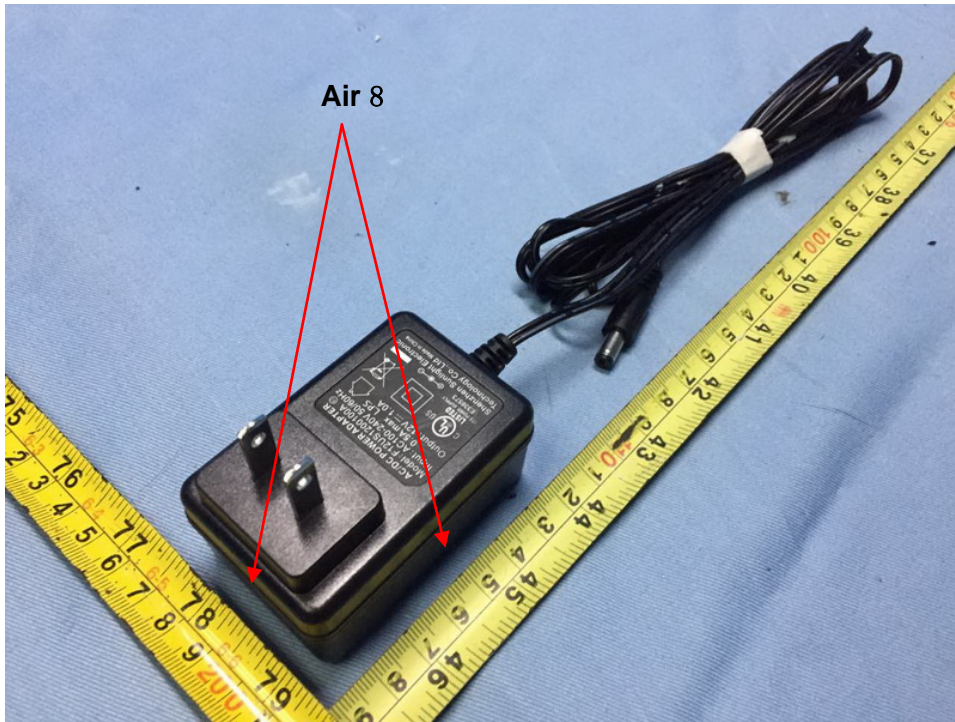

5.4 RADIATED, RADIO-FREQUENCY, ELECTROMAGNETIC FIELD IMMUNITY TEST (RS)

5.4.1 TEST SPECIFICATION

Basic Standard	EN 61000-4-3
Required Performance	A
Frequency Range	80 MHz - 1000 MHz
Field Strength	3 V/m(unmodulated, r.m.s)
Modulation	1 kHz Sine Wave, 80%, AM Modulation
Frequency Step	1% of fundamental
Polarity of Antenna	Horizontal and Vertical
Test Distance	3 m
Antenna Height	1.5 m
Dwell Time	at least 3 seconds

5.4.2 MEASUREMENT INSTRUMENTS

Item	Kind of Equipment	Manufacturer	Type No.	Serial No.	Calibrated until
1	Power amplifier	MILMEGA	80RF1000-250	1064833	Aug. 20, 2020
2	Antenna	ETS	3142C	00047662	Mar. 26, 2018
3	Measurement Software	TOYO	IM5/RS Ver 3.8.050	N/A	N/A
4	MXG Analog Signal Generator	Agilent	N5181A	MY49060710	Aug. 20, 2018
5	Audio Test System	Audio precision	ATS-1ACCESS	ATS1-45376	Mar. 26, 2018
6	Conditioning Amplifier	B&K	_2690__0F2_	2723746	Jul. 03, 2018
7	Free-field 1/2` Microphone	B&K	4190-L-001	2913343	Jun. 21, 2018

Remark: "N/A" denotes no model name, no serial No. or no calibration specified.
All calibration period of equipment list is one year.

5.4.3 TEST PROCEDURE

The EUT and support equipment, which are placed on a table that is 0.8 meter above ground and the testing was performed in a fully-anechoic chamber.

The testing distance from antenna to the EUT was 3 meters.

The other condition as following manner:

- a. The field strength level was 3 V/m(unmodulated, r.m.s).
- b. The frequency range is swept from 80 MHz to 1000 MHz, with the signal 80%amplitude modulated with a 1 kHz sine wave. The rate of sweep did not exceed 1.5×10^{-3} decade/s. Where the frequency range is swept incrementally, the step size was 1% of fundamental.
- c. The dwell time at each frequency shall be not less than the time necessary for the EUT to be able to respond.
- d. The test was performed with the EUT exposed to both vertically and horizontally polarized fields on each of the four sides.

5.4.4 DEVIATION FROM TEST STANDARD

No deviation

5.4.5 TEST SETUP

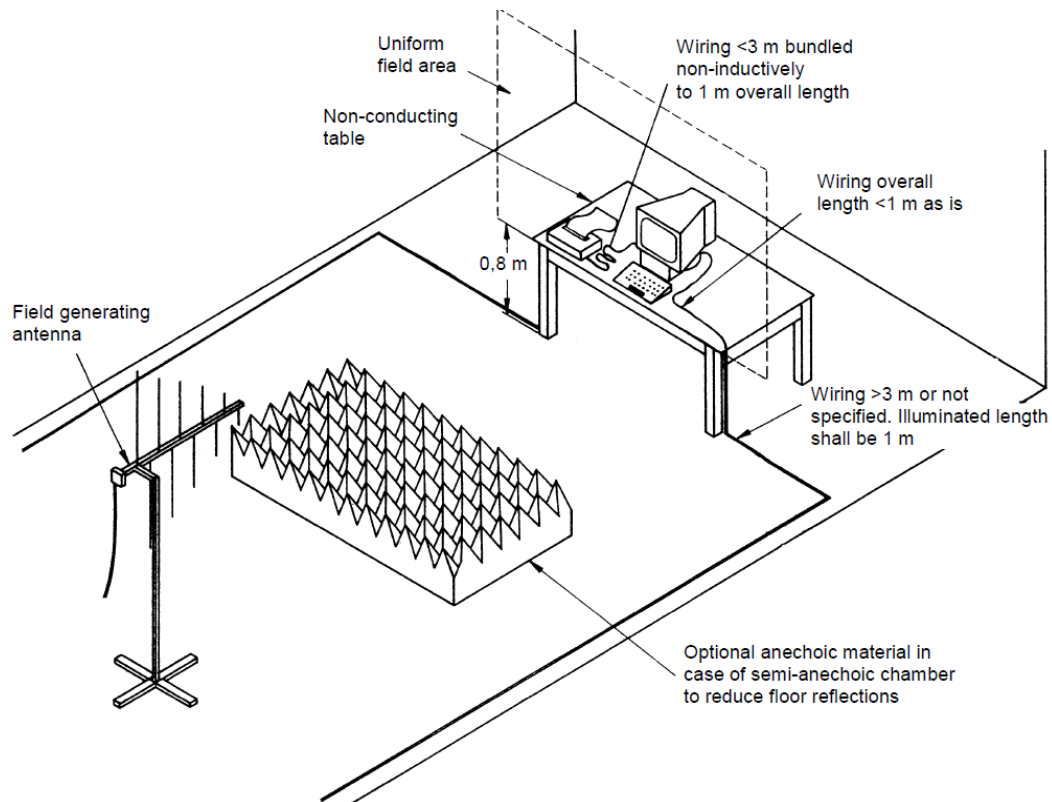

Note:

TABLE-TOP EQUIPMENT

The EUT installed in a representative system as described in EN 61000-4-3 was placed on a non-conductive table 0.8 meters in height. The system under test was connected to the power and signal wire according to relevant installation instructions.

FLOOR-STANDING EQUIPMENT

The EUT installed in a representative system as described in EN 61000-4-3 was placed on a non-conductive wood support 0.1 meters in height. The system under test was connected to the power and signal wire according to relevant installation instructions.

5.4.6 TEST RESULTS

EUT	IP Phone	Model Name	E6G
Temperature	25°C	Relative Humidity	55%
Test Voltage	AC 230V/50Hz		
Test Mode	Handfree,Handset,Headphone		

Frequency Range (MHz)	RF Field Position	R.F. Field Strength	Azimuth	Criterion	Result	Judgment
80 - 1000	H / V	3V (unmodulated, r.m.s) AM Modulated 1000Hz, 80%	0	A	A	PASS
			90			
			180			
			270			

Note:

- 1) P/N denotes the Positive/Negative polarity of the output voltage.
- 2) N/A - denotes test is not applicable in this test report.
- 3) Criterion A: No observation of any performance degradation.
- 4) Criterion B: Some degradation of performance is observed but the equipment continues to operate as intended.
- 5) Criterion C: Loss of functionality, but self-recoverable by user, without loss of information or settings.

EUT	IP Phone	Model Name	E6G
Temperature	25°C	Relative Humidity	55%
Test Voltage	AC 230V/50Hz	Polarization	Vertical
Test Mode	Handset		
Note	Adapter Rear		

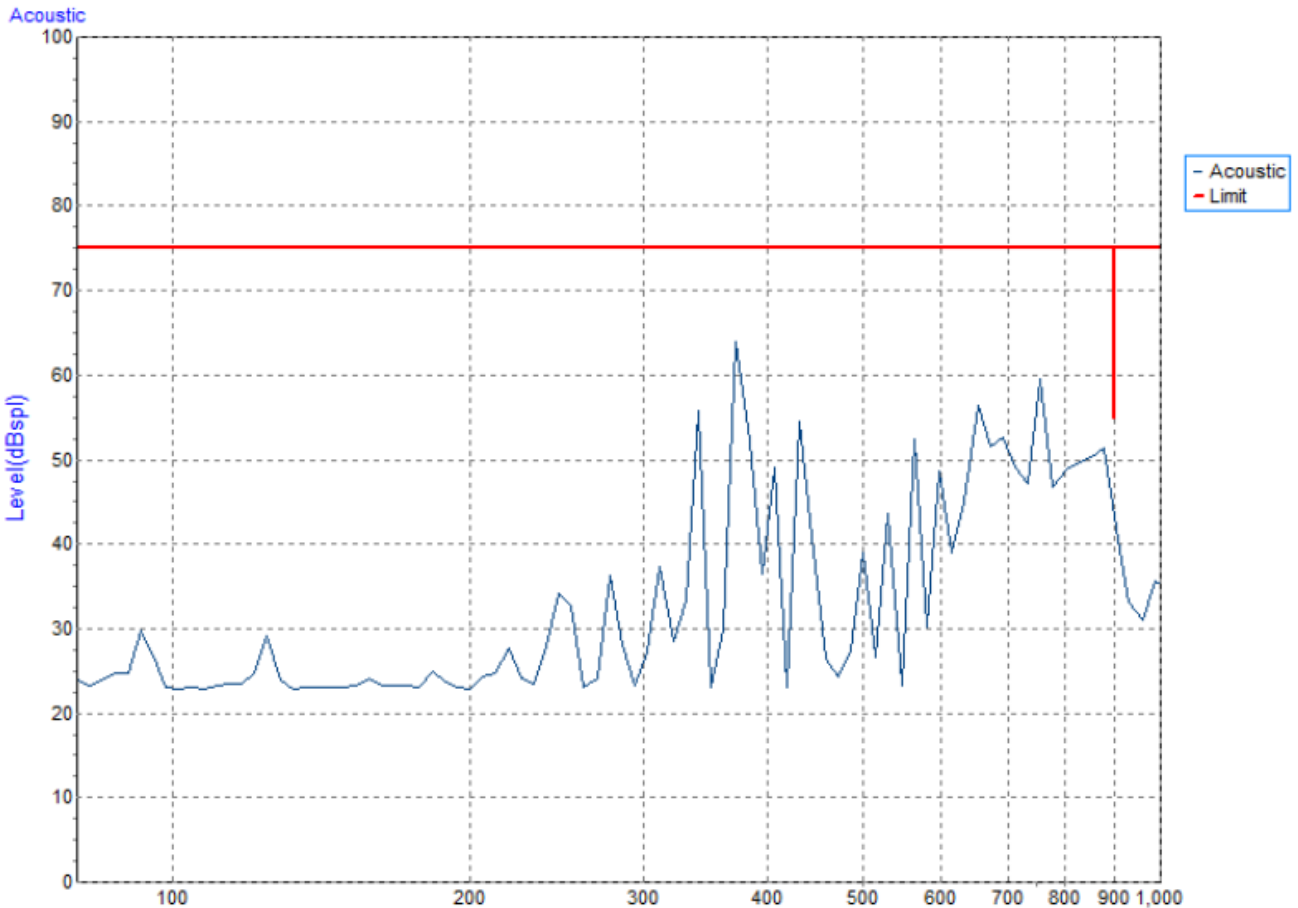

EUT	IP Phone	Model Name	E6G
Temperature	25°C	Relative Humidity	55%
Test Voltage	AC 230V/50Hz	Polarization	Horizontal
Test Mode	Handset		
Note	Adapter Rear		

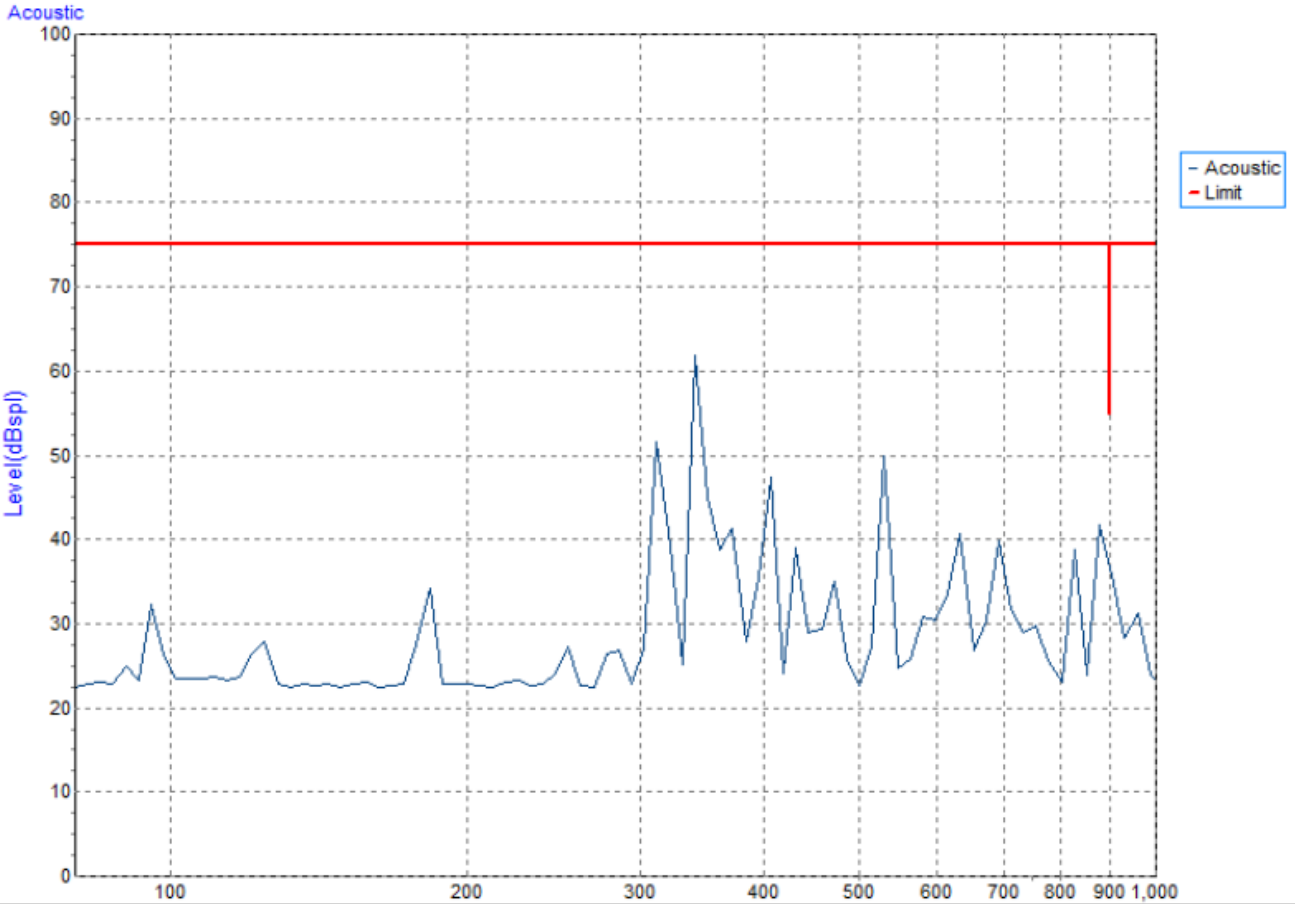

EUT	IP Phone	Model Name	E6G
Temperature	25°C	Relative Humidity	55%
Test Voltage	DC 48V	Polarization	Vertical
Test Mode	Handset		
Note	PoE Rear		

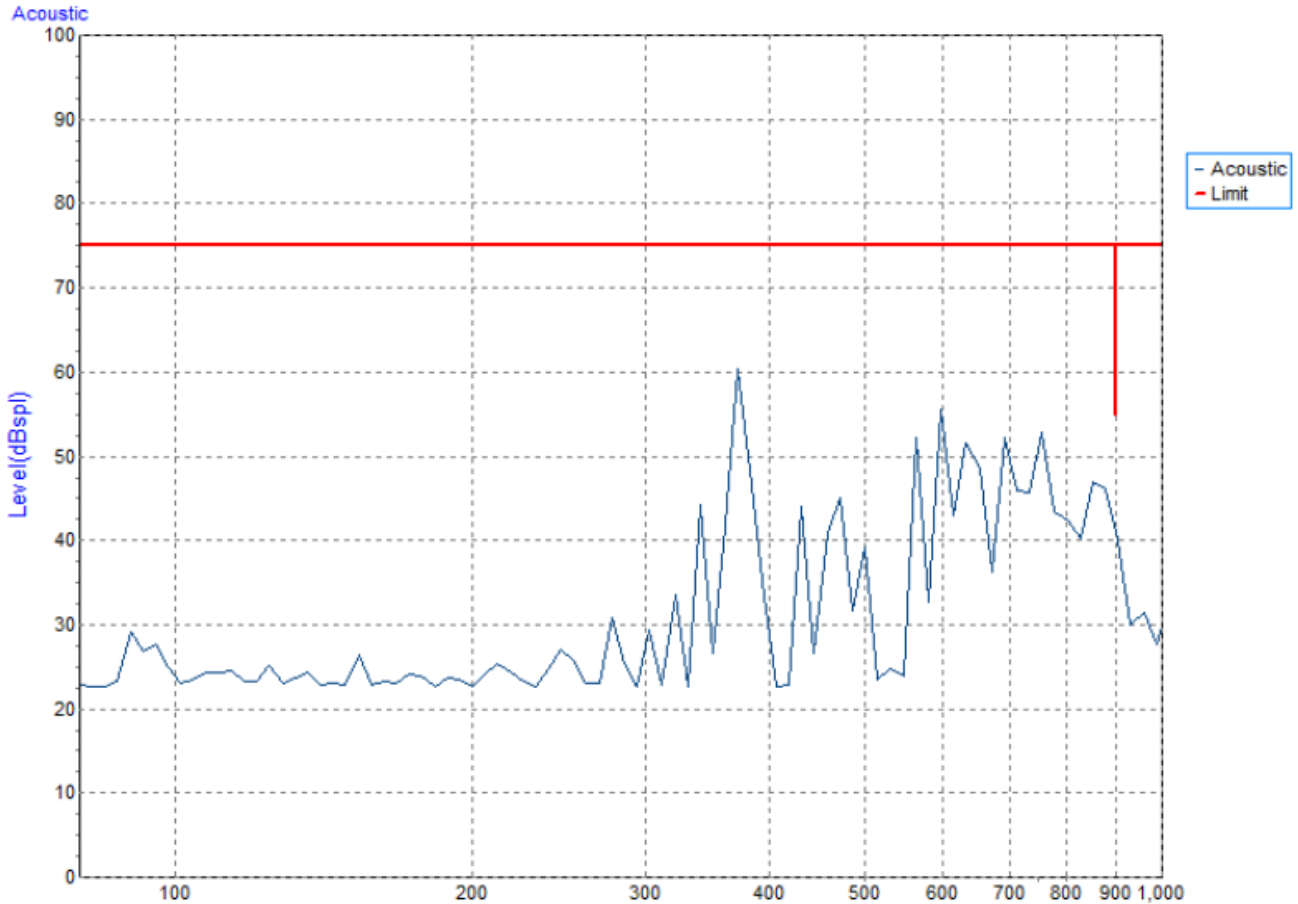

EUT	IP Phone	Model Name	E6G
Temperature	25°C	Relative Humidity	55%
Test Voltage	DC 48V	Polarization	Horizontal
Test Mode	Handset		
Note	PoE Rear		

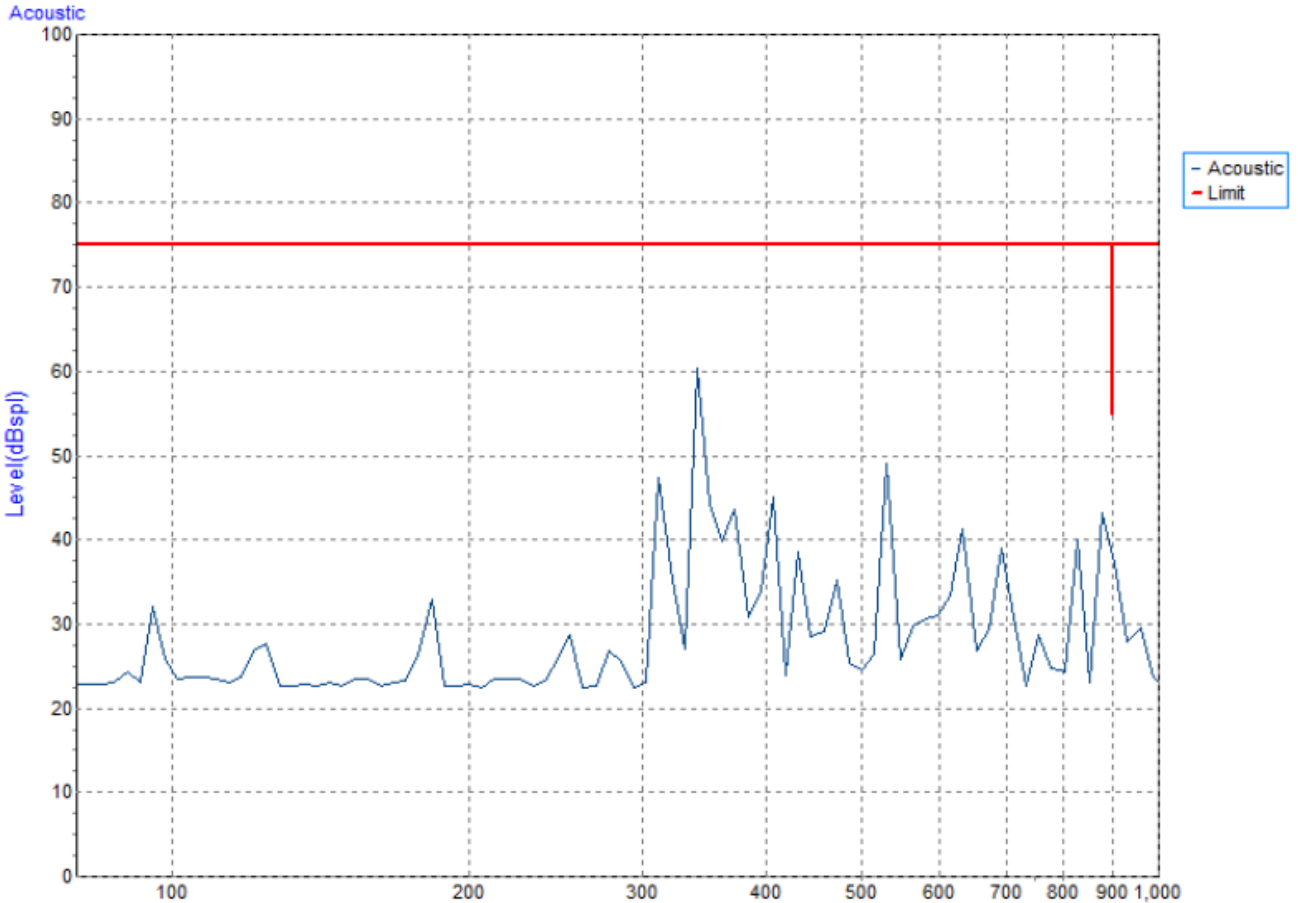

EUT	IP Phone	Model Name	E6G
Temperature	25°C	Relative Humidity	55%
Test Voltage	AC 230V/50Hz	Polarization	Vertical
Test Mode	Handfree		
Note	Adapter Rear		

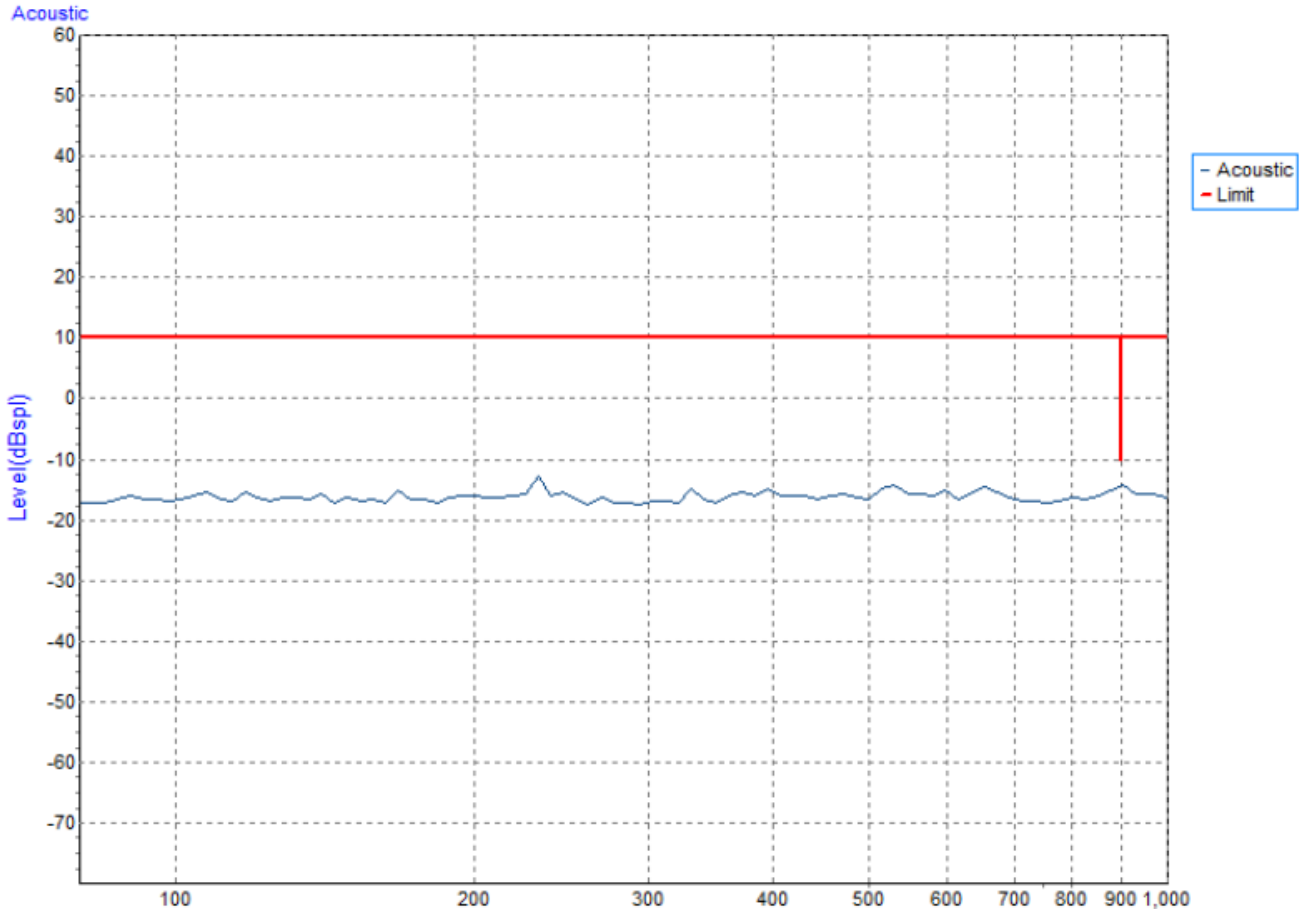

EUT	IP Phone	Model Name	E6G
Temperature	25°C	Relative Humidity	55%
Test Voltage	AC 230V/50Hz	Polarization	Horizontal
Test Mode	Handfree		
Note	Adapter Rear		

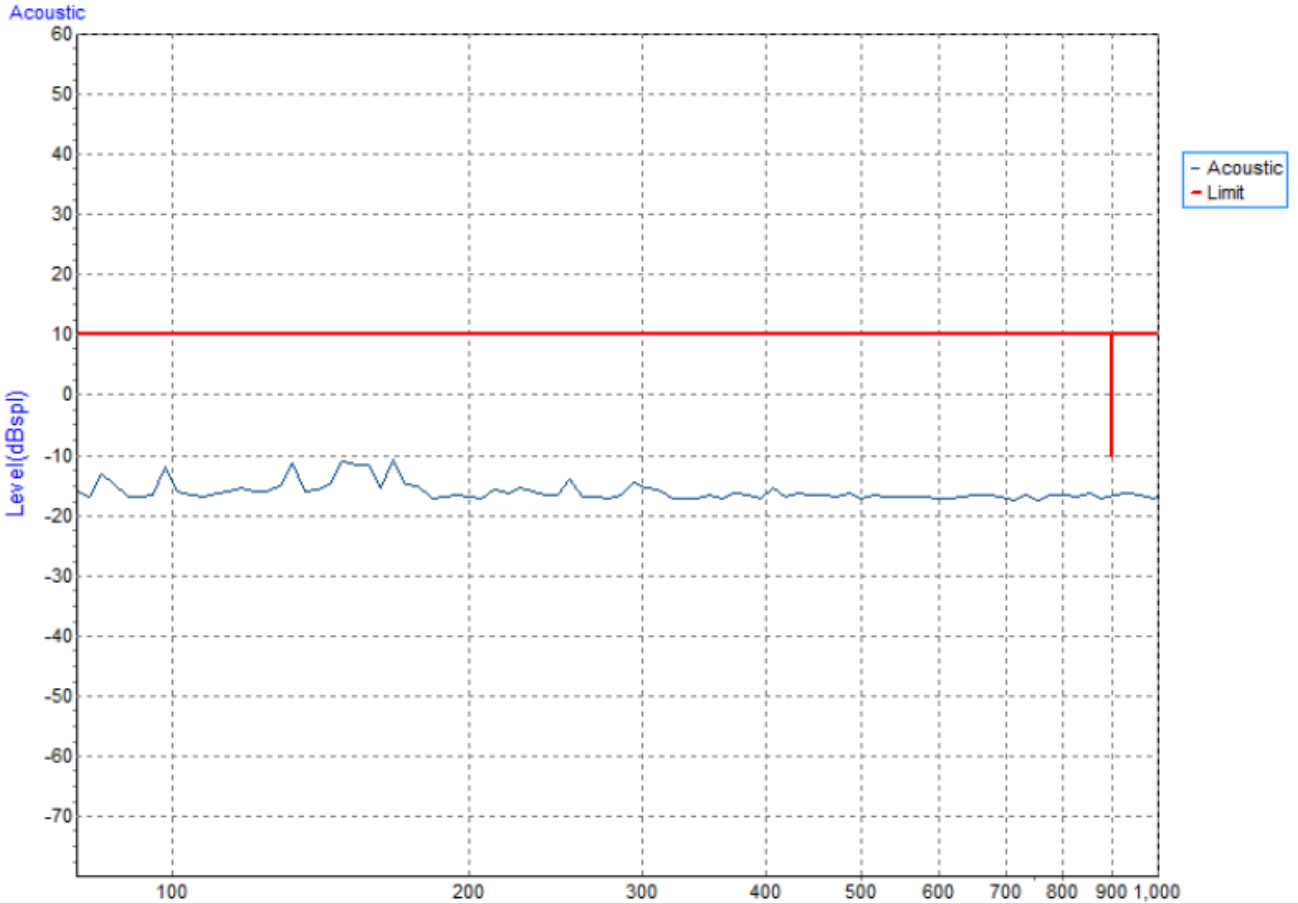

EUT	IP Phone	Model Name	E6G
Temperature	25°C	Relative Humidity	55%
Test Voltage	DC 48V	Polarization	Vertical
Test Mode	Handfree		
Note	PoE Rear		

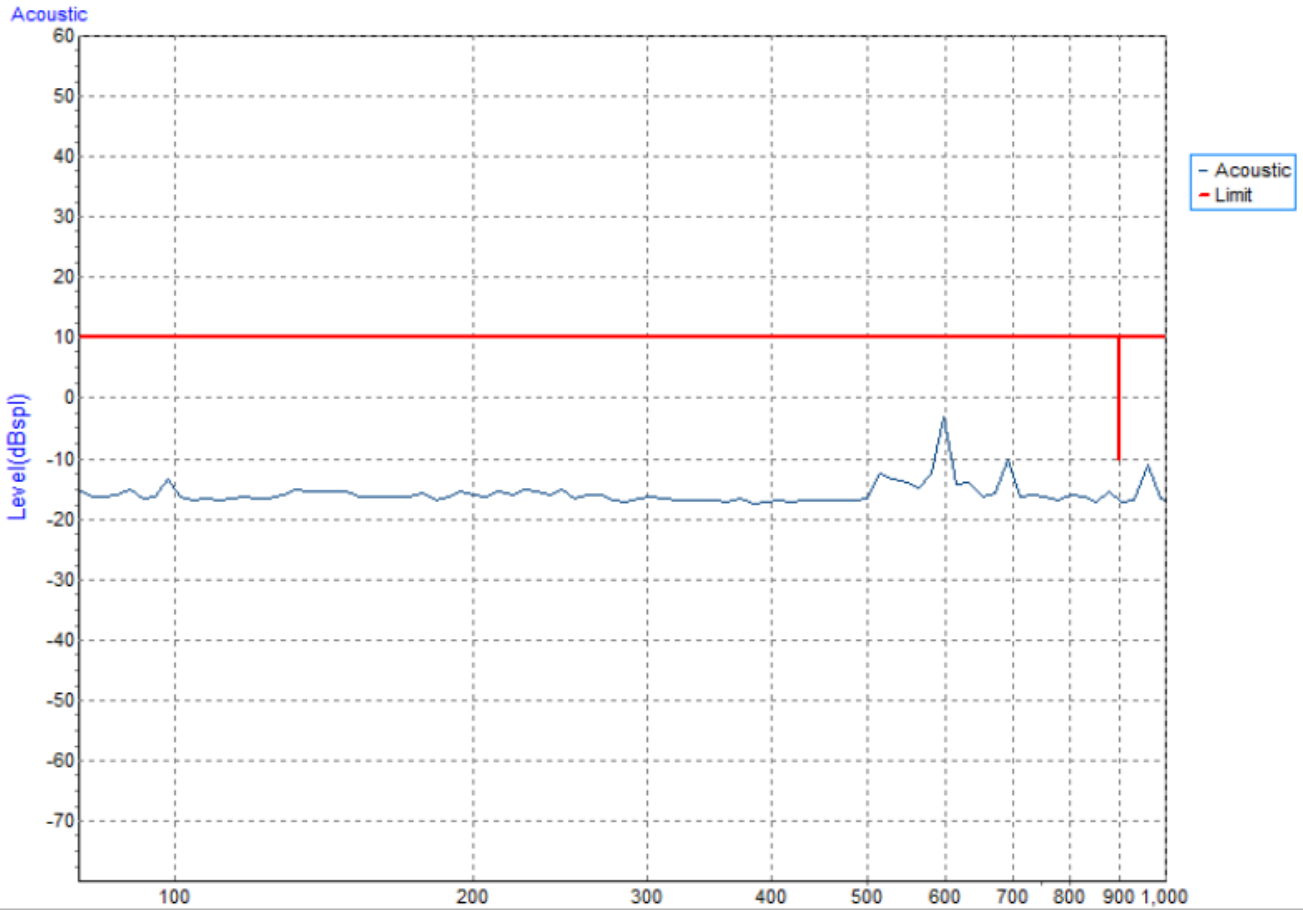

EUT	IP Phone	Model Name	E6G
Temperature	25°C	Relative Humidity	55%
Test Voltage	DC 48V	Polarization	Horizontal
Test Mode	Handfree		
Note	PoE Rear		

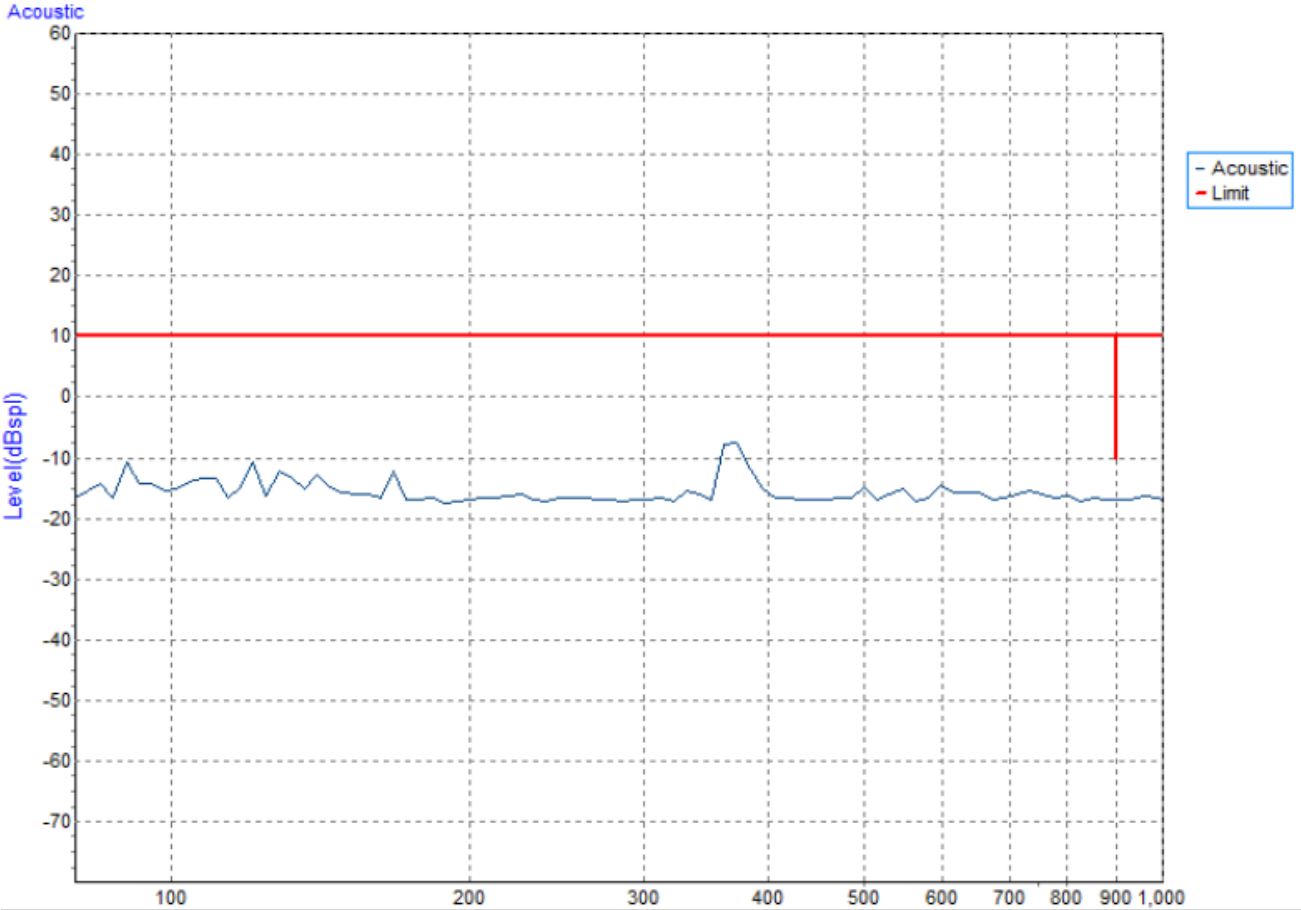

5.5 ELECTRICAL FAST TRANSIENT/BURST IMMUNITY TEST (EFT/BURST)

5.5.1 TEST SPECIFICATION

Basic Standard	EN 61000-4-4
Required Performance	B
Test Voltage	Power Line: ± 1 kV Signal/Control Line: ± 0.5 kV
Polarity	Positive & Negative
Impulse Frequency	5 kHz: except for xDSL equipment 100 kHz: only for single lines of xDSL equipment.
Impulse Wave shape	5/50 ns
Burst Duration	15 ms
Burst Period	300 ms
Test Duration	Not less than 1 min.

5.5.2 MEASUREMENT INSTRUMENTS

Item	Kind of Equipment	Manufacturer	Type No.	Serial No.	Calibrated until
1	Capacitor Clamp	Thermo KeyTek	CCL	0502215	Feb. 24, 2018
2	THE MODULAR SOLUTION FOR 6 KV APPLICATIONS	Teseq	NSG 3060	1423	Aug. 20, 2018
3	Measurement Software	Teseq	Win 3000 Version 1.2.0	N/A	N/A

Remark: "N/A" denotes no model name, no serial No. or no calibration specified.

All calibration period of equipment list is one year.

5.5.3 TEST PROCEDURE

The EUT and support equipment(s) are placed on a table that is 0.8 meter high above a metal ground plane and should be located 0.1 m \pm 0.01m high above the Ground Reference Plane (1m*1m min. and 0.65mm thick min).

The other condition as following manner:

- The length of power cord between the coupling device and the EUT should not exceed 1 meter.
- Both positive and negative polarity discharges were applied.
- The duration time of each test sequential was 1 minute

5.5.4 DEVIATION FROM TEST STANDARD

No deviation

5.5.5 TEST SETUP

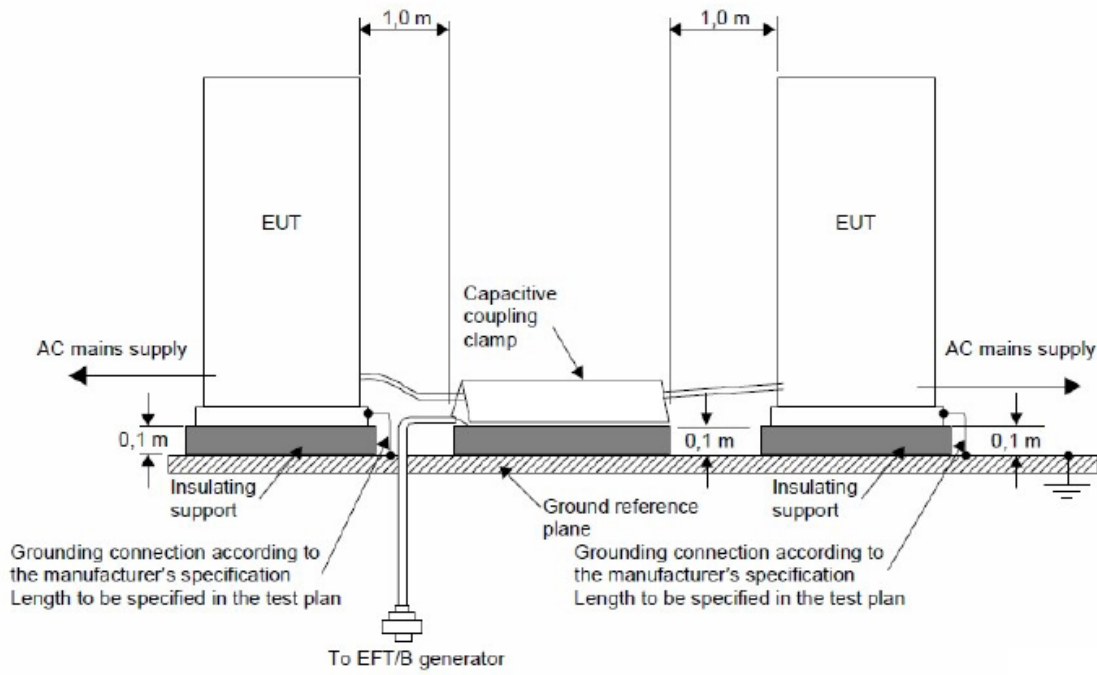
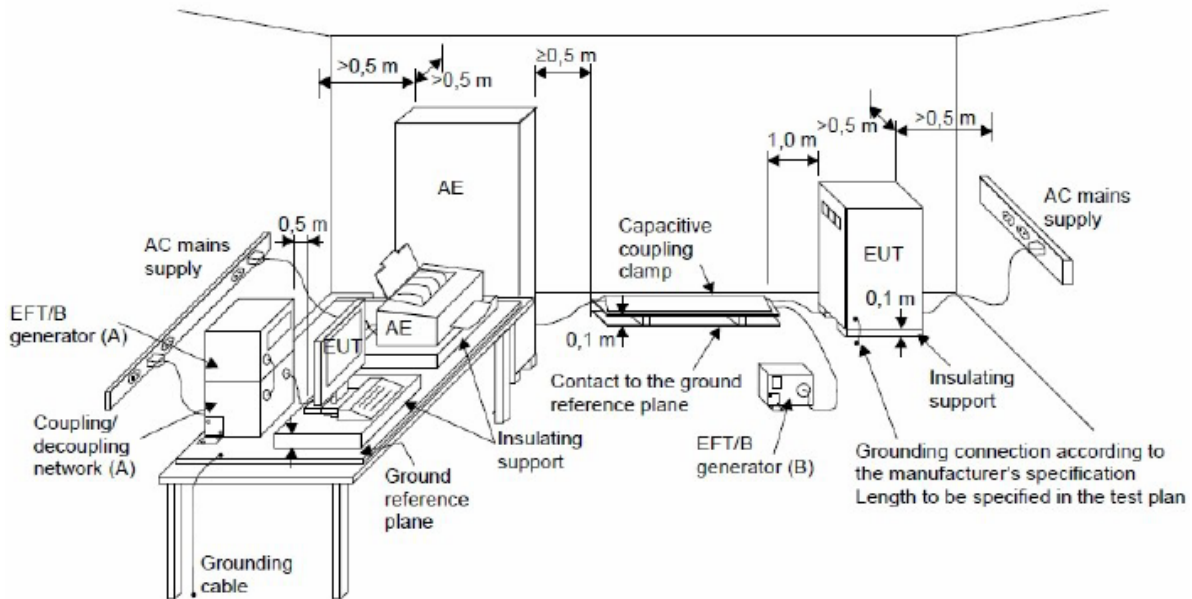

Note:

TABLE-TOP EQUIPMENT

The configuration consisted of a wooden table (0.8m high) standing on the Ground Reference Plane and should be located 0.1 m+/- 0.01m above the Ground Reference Plane. The GRP consisted of a sheet of aluminum (at least 0.25mm thick and 2.5m square) connected to the protective grounding system. A minimum distance of 0.5m was provided between the EUT and the walls of the laboratory or any other metallic structure.

FLOOR-STANDING EQUIPMENT

The EUT installed in a representative system as described in EN 61000-4-4 and its cables were isolated from the Ground Reference Plane by an insulating support that is 0.1-meter thick. The GRP consisted of a sheet of aluminum (at least 0.25mm thick and 2.5m square) connected to the protective grounding system.

5.5.6 TEST RESULTS

EUT	IP Phone	Model Name	E6G
Temperature	25°C	Relative Humidity	51%
Test Voltage	AC 230V/50Hz		
Test Mode	Handfree,Handset,Headphone		

EUT Ports Tested		Polarity	Repetition Frequency	Test Level 1kV	Criterion	Result	Judgment
AC Power Port	Line (L)	+	5 kHz	A	B	A	PASS
		-	5 kHz	A			
	Neutral (N)	+	5 kHz	A	B	A	PASS
		-	5 kHz	A			
	Ground (PE)	+	5 kHz	N/A	B	N/A	PASS
		-	5 kHz	N/A			

EUT Ports Tested		Polarity	Repetition Frequency	Test Level 0.5 kV	Criterion	Result	Judgment
Signal/Data/ Control Port	PC Port	+	5 kHz	A	B	A	PASS
		-	5 kHz	A			
Signal/Data/ Control Port	Internet Port	+	5 kHz	A	B	A	PASS
		-	5 kHz	A			

Note:

- 1) P/N denotes the Positive/Negative polarity of the output voltage.
- 2) N/A - denotes test is not applicable in this test report
- 3) Criterion A: No observation of any performance degradation.
- 4) Criterion B: Some degradation of performance is observed but the equipment continues to operate as intended.
- 5) Criterion C: Loss of functionality, but self-recoverable by user, without loss of information or settings.

5.6 SURGE IMMUNITY TEST

5.6.1 TEST SPECIFICATION

Basic Standard	EN 61000-4-5
Required Performance	B
Wave-Shape	Combination Wave for power lines 1.2/50 us Open Circuit Voltage 8 /20 us Short Circuit Current
Test Voltage	Power Line: ± 0.5 kV, ± 1 kV
Surge Input/Output	L-N
Generator Source Impedance	2 ohm between networks
Polarity	Positive/Negative
Phase Angle:	AC Port: $0^\circ/90^\circ/180^\circ/270^\circ$
Pulse Repetition Rate	1 time / min. (maximum)
Number of Tests	5 positive and 5 negative at selected points

5.6.2 MEASUREMENT INSTRUMENTS

Item	Kind of Equipment	Manufacturer	Type No.	Serial No.	Calibrated until
1	THE MODULAR SOLUTION FOR 6 KV APPLICATIONS	Teseq	NSG 3060	1423	Aug. 20, 2018
2	Measurement Software	Teseq	Win 3000 Version 1.2.0	N/A	N/A

Remark: "N/A" denotes no model name, no serial No. or no calibration specified.
All calibration period of equipment list is one year.

5.6.3 TEST PROCEDURE

a. For EUT power supply:

The surge is to be applied to the EUT power supply terminals via the capacitive coupling network. Decoupling networks are required in order to avoid possible adverse effects on equipment not under test that may be powered by the same lines, and to provide sufficient decoupling impedance to the surge wave. The power cord between the EUT and the coupling/decoupling networks shall be 2meters in length (or shorter).

b. For test applied to unshielded unsymmetrically operated interconnection lines of EUT :

The surge is applied to the lines via the capacitive coupling. The coupling /decoupling networks shall not influence the specified functional conditions of the EUT. The interconnection line between the EUT and the coupling/decoupling networks shall be 2 meters in length (or shorter).

c. For test applied to unshielded symmetrically operated interconnection /telecommunication lines of EUT :

The surge is applied to the lines via gas arrestors coupling. Test levels below the ignition point of the coupling arrester cannot be specified. The interconnection line between the EUT and the coupling/decoupling networks shall be 2 meters in length (or shorter).

5.6.4 DEVIATION FROM TEST STANDARD

No deviation

5.6.5 TEST SETUP

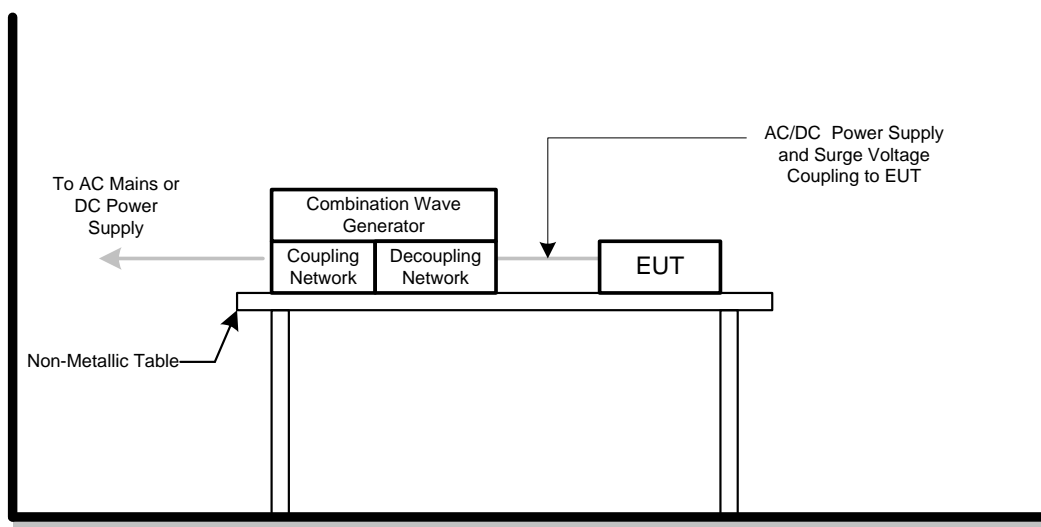

5.6.6 TEST RESULTS

EUT	IP Phone	Model Name	E6G
Temperature	25°C	Relative Humidity	55%
Test Voltage	AC 230V/50Hz		
Test Mode	Handfree,Handset,Headphone		

Wave Form EUT Ports Tested		1.2/50(8/20)Tr/Thµs						Criterion	Result	Judgment
		Polarity	Phase	Voltage						
				0.5kV	1kV	-- kV	-- kV			
AC	L – N (2 ohm)	+/-	0°	A	A	-	-	B	A	PASS
		+/-	90°	A	A	-	-			
		+/-	180°	A	A	-	-			
		+/-	270°	A	A	-	-			

Note:

- 1) Polarity and Numbers of Impulses: 5 Pst / Ngst at each tested mode
- 2) N/A - denotes test is not applicable in this Test Report
- 3) Criterion A: No observation of any performance degradation.
- 4) Criterion B: Some degradation of performance is observed but the equipment continues to operate as intended.
- 5) Criterion C: Loss of functionality, but self-recoverable by user, without loss of information or settings.

5.7 IMMUNITY TO CONDUCTED DISTURBANCES, INDUCED BY RADIO-FREQUENCY FIELDS TEST (CS)

5.7.1 TEST SPECIFICATION

Basic Standard	EN 61000-4-6
Required Performance	A
Frequency Range	0.15 MHz - 80 MHz
Field Strength	3 V (unmodulated, r.m.s.)
Modulation	1 kHz Sine Wave, 80%, AM Modulation
Frequency Step	1% of fundamental
Dwell Time	at least 3 seconds

5.7.2 MEASUREMENT INSTRUMENTS

Item	Kind of Equipment	Manufacturer	Type No.	Serial No.	Calibrated until
1	Power CDN	FCC	FCC-801-M2/M3-16A	100270	Mar. 26, 2018
2	Power Amplifier	Teseq	CBA230M-080	T43748	Mar. 26, 2018
3	Signal Generator	HP	8648A	3636A02964	Mar. 26, 2018
4	Measurement Software	Farad	EZ-CS(V2.0 .1.2)	N/A	N/A
5	Signal Line CDN	FCC	F-090407-1004-1	100518	Mar. 26, 2018
6	Audio Test System	Audio precision	ATS-1ACC ESS	ATS1-45376	Mar. 26, 2018
7	Conditioning Amplifier	B&K	_2690__0F2_	2723746	Jul. 03, 2018
8	Free-field 1/2` Microphone	B&K	4190-L-001	2913343	Jun. 21, 2018

Remark: "N/A" denotes no model name, no serial No. or no calibration specified.
All calibration period of equipment list is one year.

5.7.3 TEST PROCEDURE

The EUT and support equipment, are placed on a table that is 0.8 meter above a metal ground plane measured 1m*1m min. and 0.65mm thick min.

The other condition as following manner:

- The field strength level was 3 V (unmodulated, r.m.s.)
- The frequency range is swept from 150 kHz to 80 MHz, with the signal 80% amplitude modulated with a 1 kHz sine wave. The rate of sweep did not exceed 1.5×10^{-3} decade/s. Where the frequency range is swept incrementally, the step size was 1% of fundamental.
- The dwell time at each frequency shall be not less than the time necessary for the EUT to be able to respond.

5.7.4 DEVIATION FROM TEST STANDARD

No deviation

5.7.5 TEST SETUP

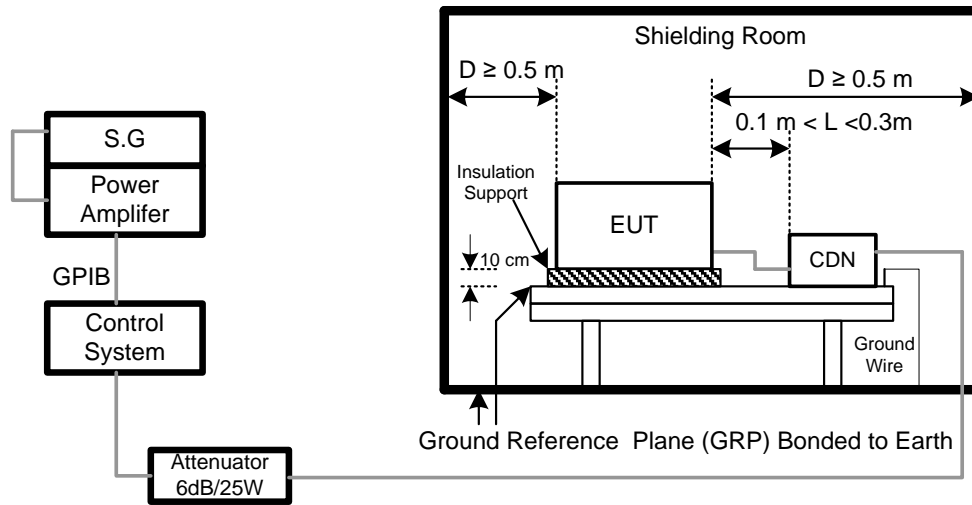

NOTE:

FLOOR-STANDING EQUIPMENT

The equipment to be tested is placed on an insulating support of 0.1 meters height above a ground reference plane. All relevant cables shall be provided with the appropriate coupling and decoupling devices at a distance between 0.1 meters and 0.3 meters from the projected geometry of the EUT on the ground reference plane.

5.7.6 TEST RESULTS

EUT	IP Phone	Model Name	E6G
Temperature	25°C	Relative Humidity	57%
Test Voltage	AC 230V/50Hz		
Test Mode	Handfree,Handset,Headphone		

Test Ports (Mode)	Freq.Range (MHz)	Field Strength	Criteria	Results	Judgment
Input/ Output AC.PowerPort	0.15 ---80	3V(unmodulated, r.m.s) AM Modulated 1000Hz, 80%	A	A	PASS
Input/ Output DC. PowerPort	0.15 --- 80		A	N/A	N/A
Signal Line (PC Port)	0.15 --- 80		A	A	PASS
Signal Line (Internet Port)	0.15 --- 80		A	A	PASS

Note:

- 1). N/A - denotes test is not applicable in this test report.
- 2) Criterion A: No observation of any performance degradation.
- 3) Criterion B: Some degradation of performance is observed but the equipment continues to operate as intended.
- 4) Criterion C: Loss of functionality, but self-recoverable by user, without loss of information or settings.

EUT	IP Phone	Model Name	E6G
Temperature	25°C	Relative Humidity	55%
Test Voltage	AC 230V/50Hz		
Test Mode	Handset		
Note	Adapter, Internet Port, CDN T8		

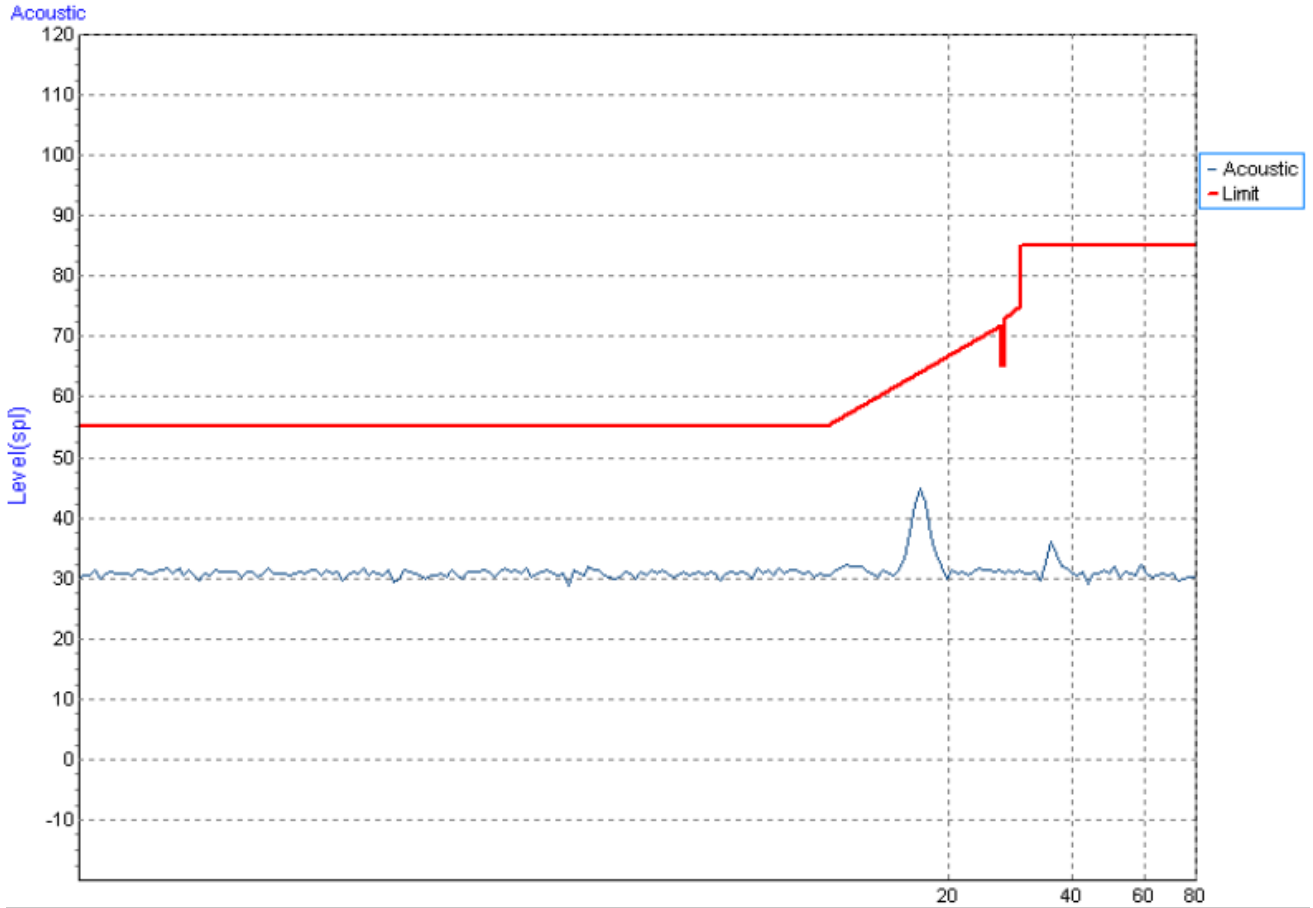

EUT	IP Phone	Model Name	E6G
Temperature	25°C	Relative Humidity	55%
Test Voltage	AC 230V/50Hz		
Test Mode	Handset		
Note	Adapter CDN M2		

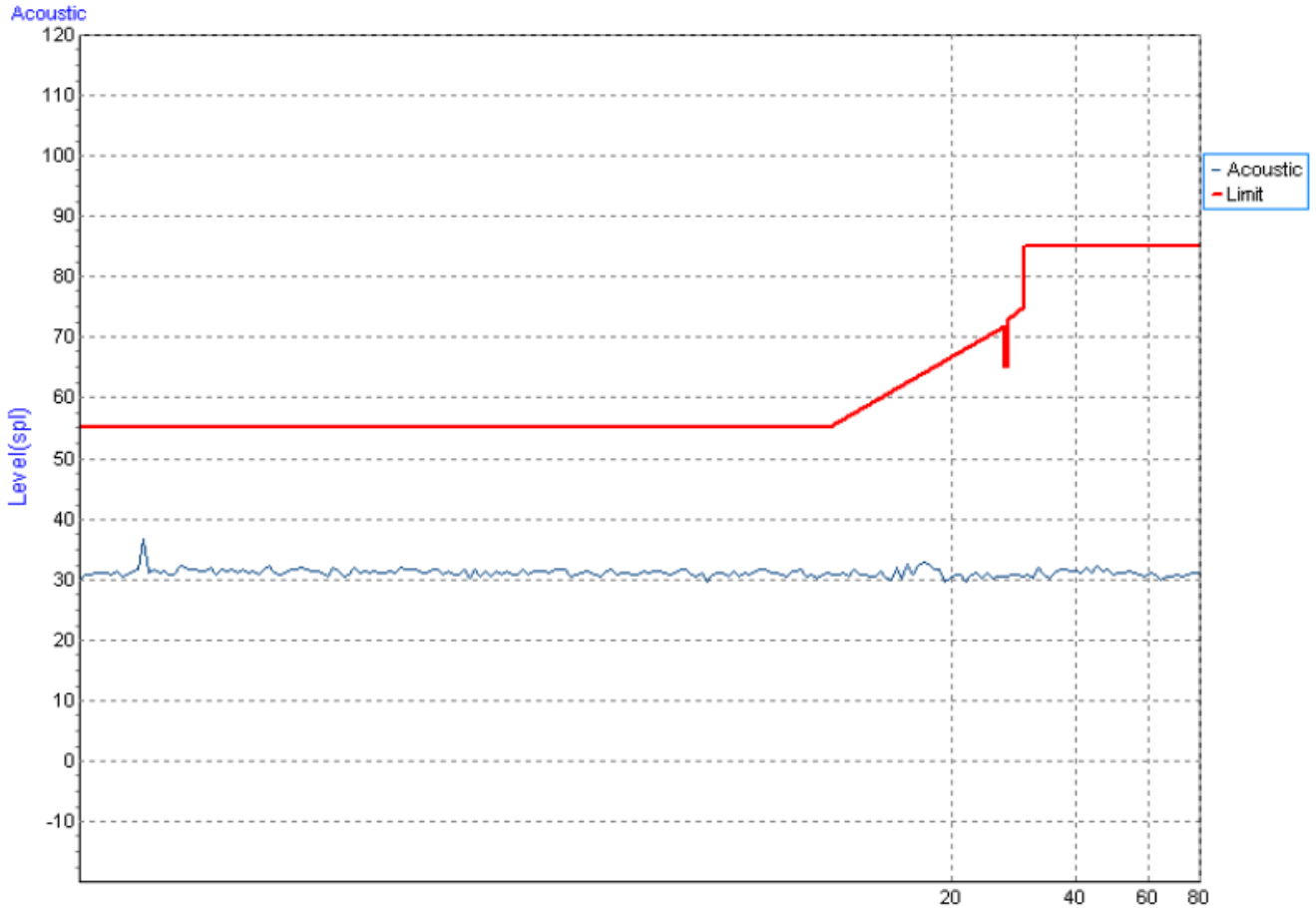

EUT	IP Phone	Model Name	E6G
Temperature	25°C	Relative Humidity	55%
Test Voltage	AC 230V/50Hz		
Test Mode	Handset		
Note	Adapter, PC Port, CDN T8		

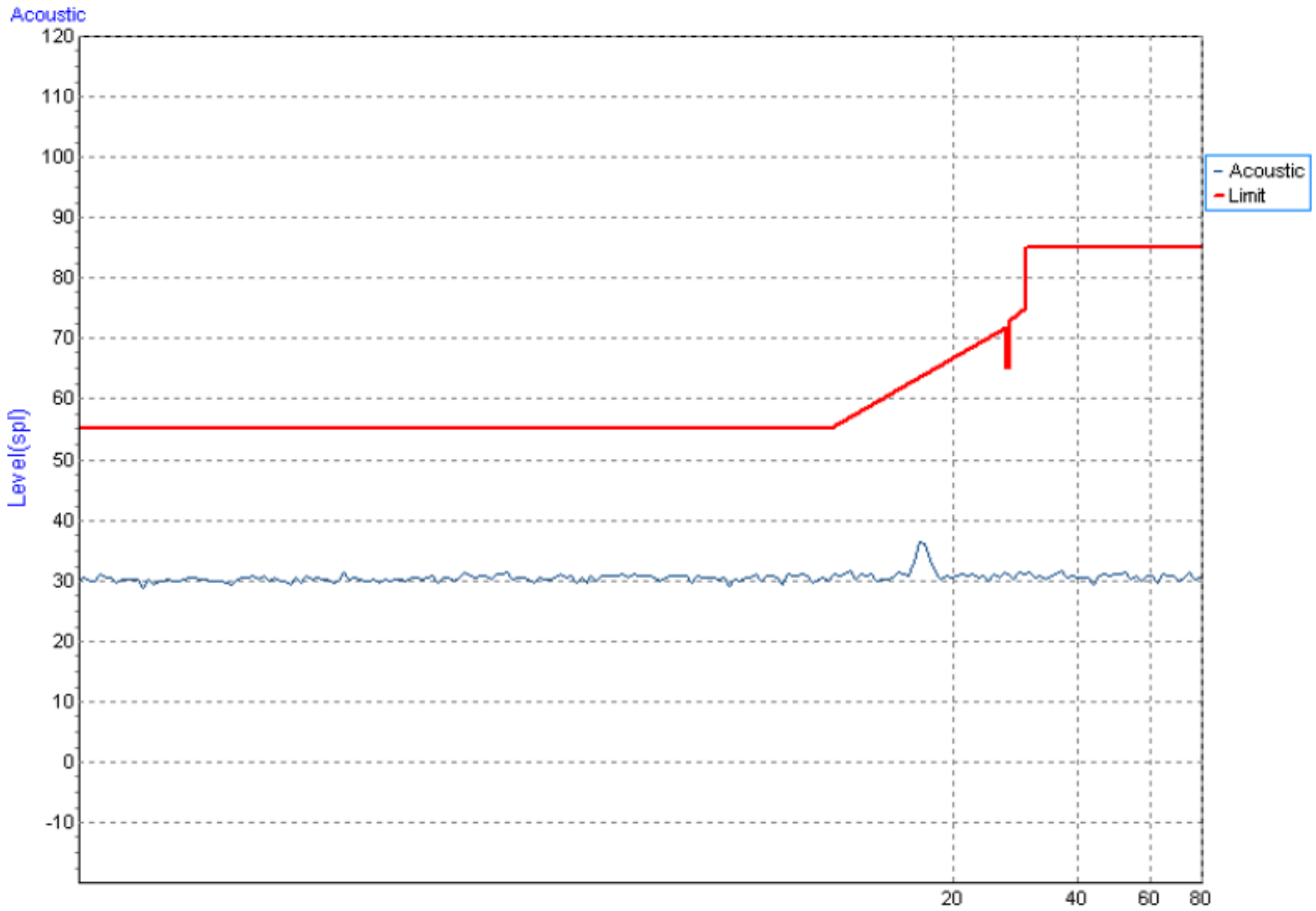

EUT	IP Phone	Model Name	E6G
Temperature	25°C	Relative Humidity	55%
Test Voltage	DC 48V		
Test Mode	Handset		
Note	PoE, Internet Port, CDN T8		

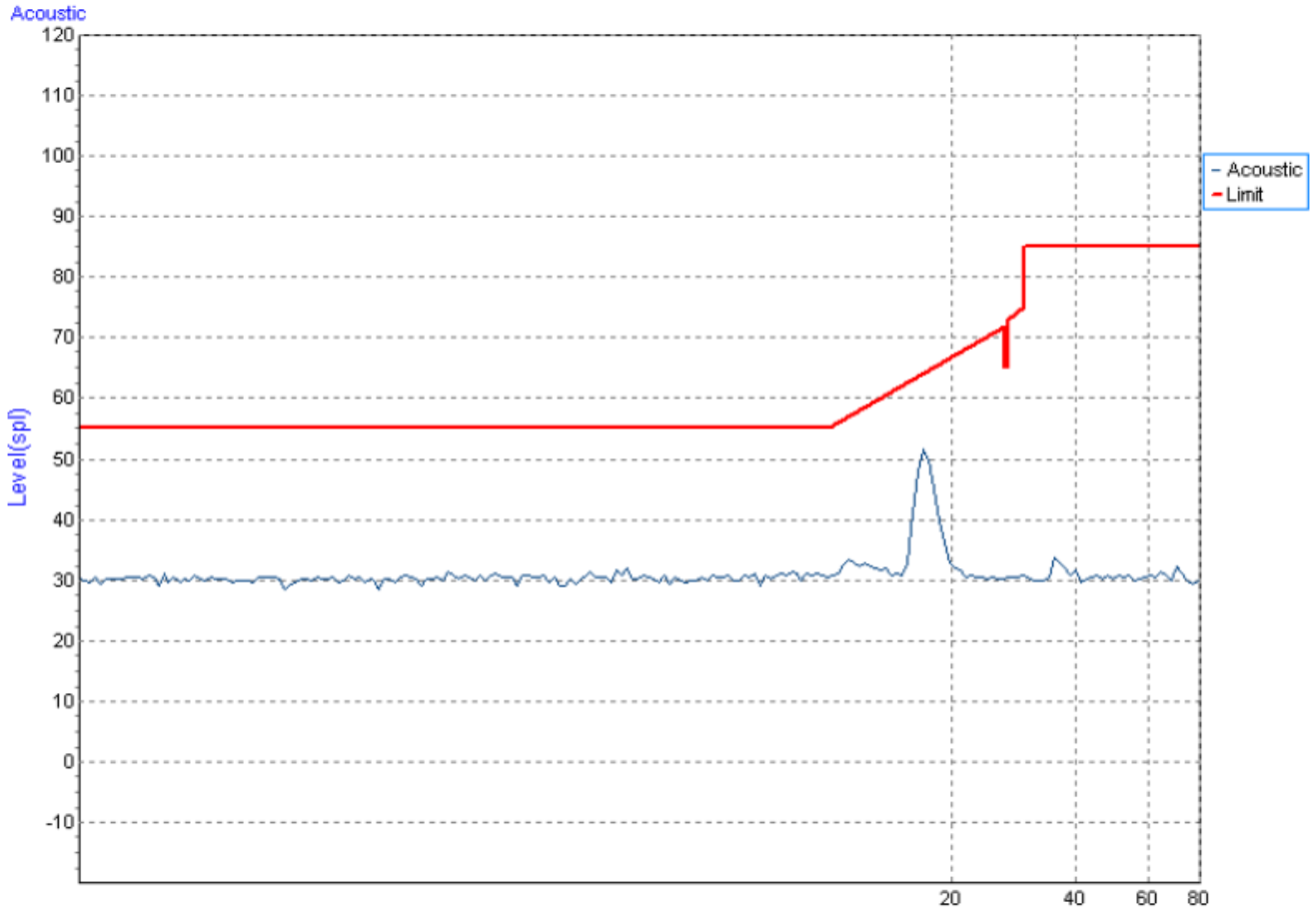

EUT	IP Phone	Model Name	E6G
Temperature	25°C	Relative Humidity	55%
Test Voltage	DC 48V		
Test Mode	Handset		
Note	PoE, PC Port, CDN T8		

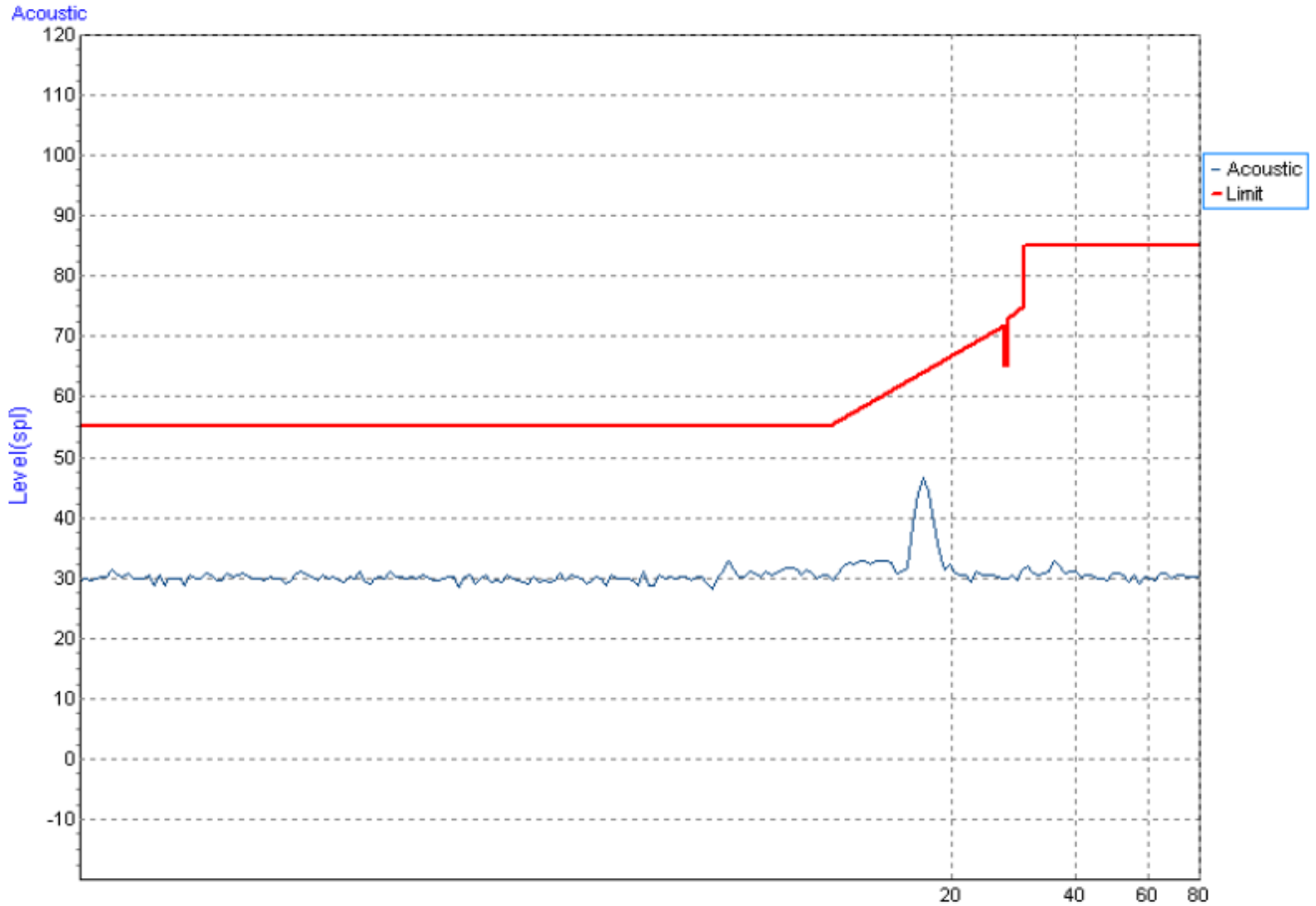

EUT	IP Phone	Model Name	E6G
Temperature	25°C	Relative Humidity	55%
Test Voltage	AC 230V/50Hz		
Test Mode	Handfree		
Note	Adapter, Internet Port, CDN T8		

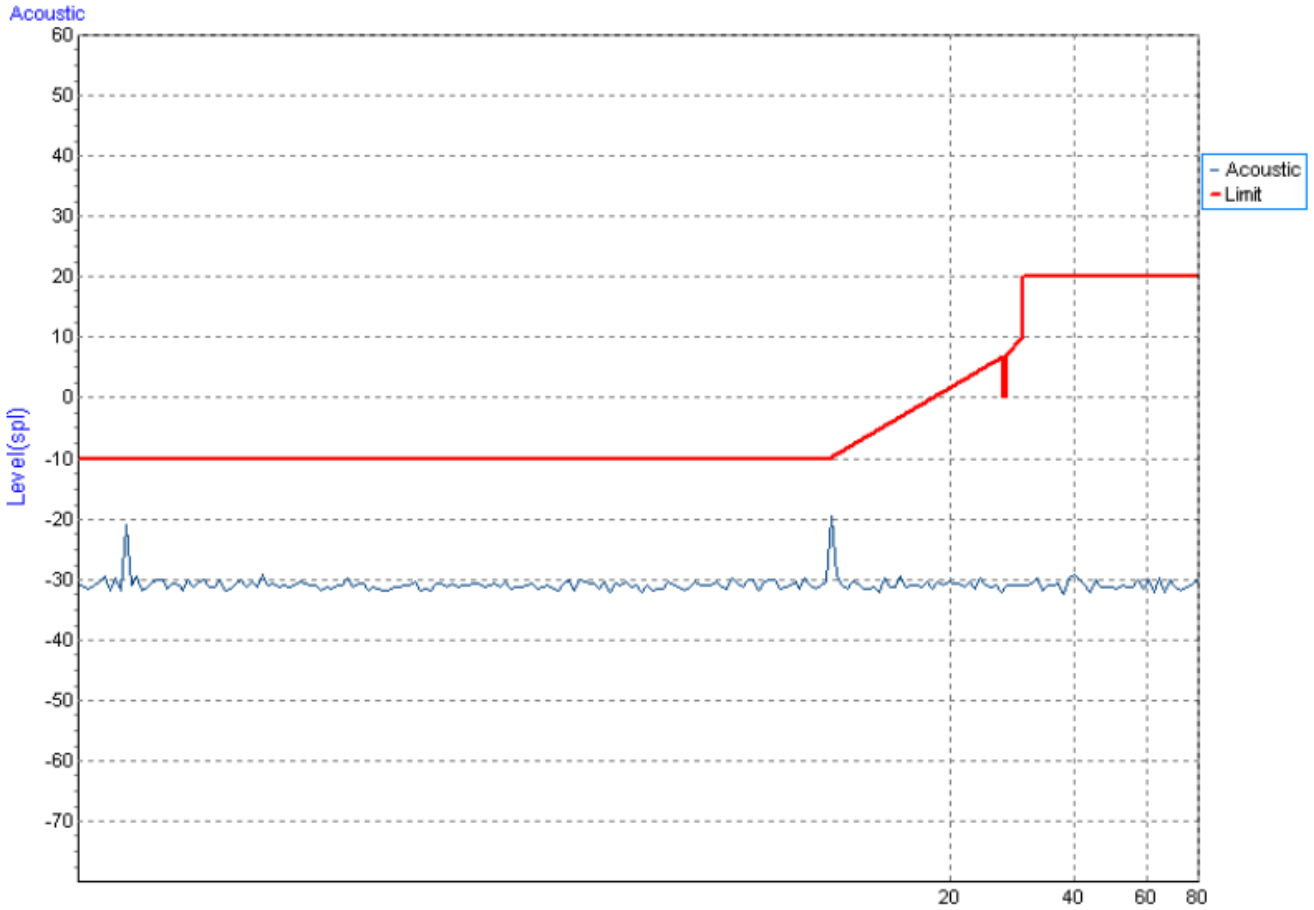

EUT	IP Phone	Model Name	E6G
Temperature	25°C	Relative Humidity	55%
Test Voltage	AC 230V/50Hz		
Test Mode	Handfree		
Note	Adapter, CDN M2		

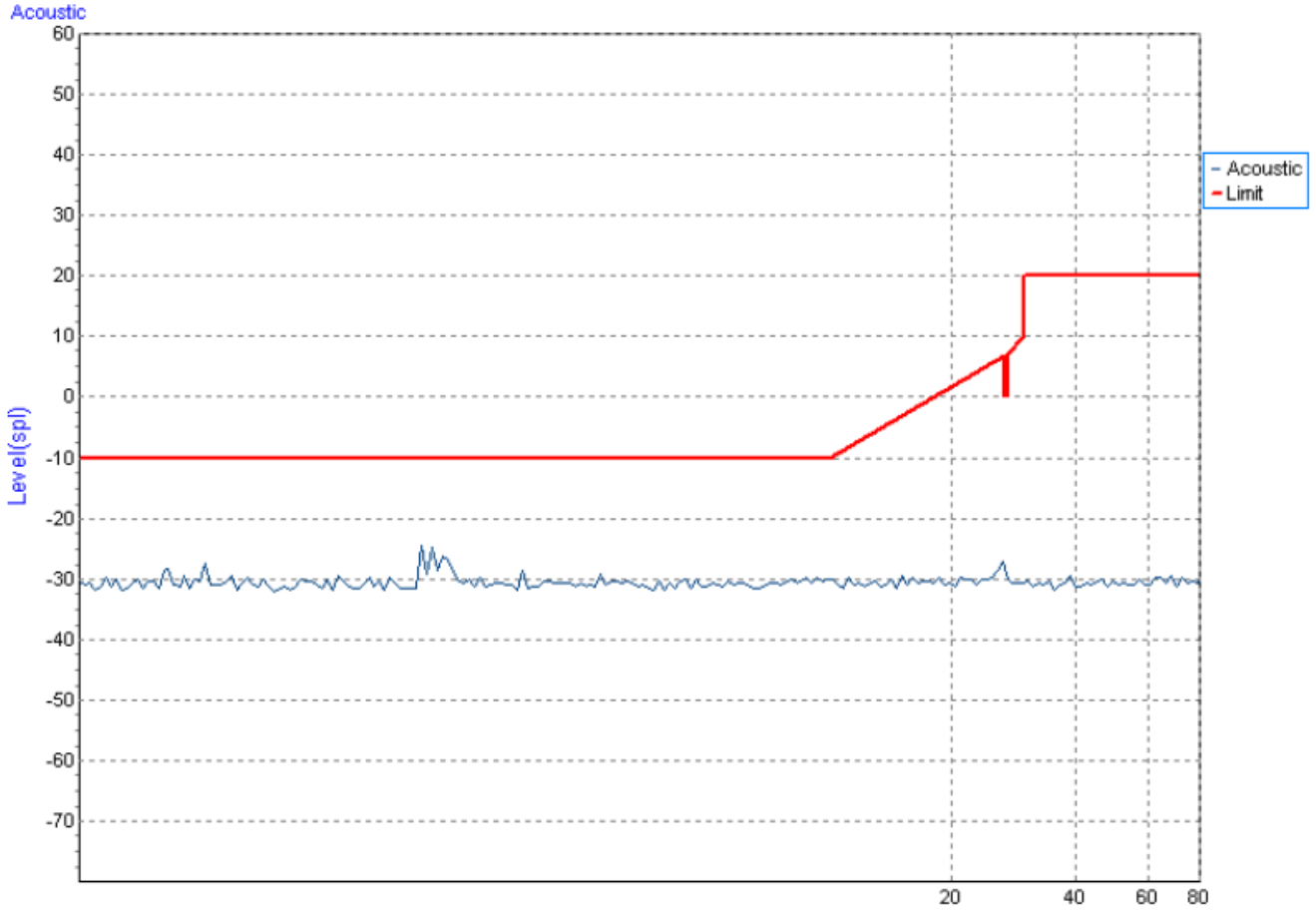

EUT	IP Phone	Model Name	E6G
Temperature	25°C	Relative Humidity	55%
Test Voltage	AC 230V/50Hz		
Test Mode	Handfree		
Note	Adapter, PC Port, CDN T8		

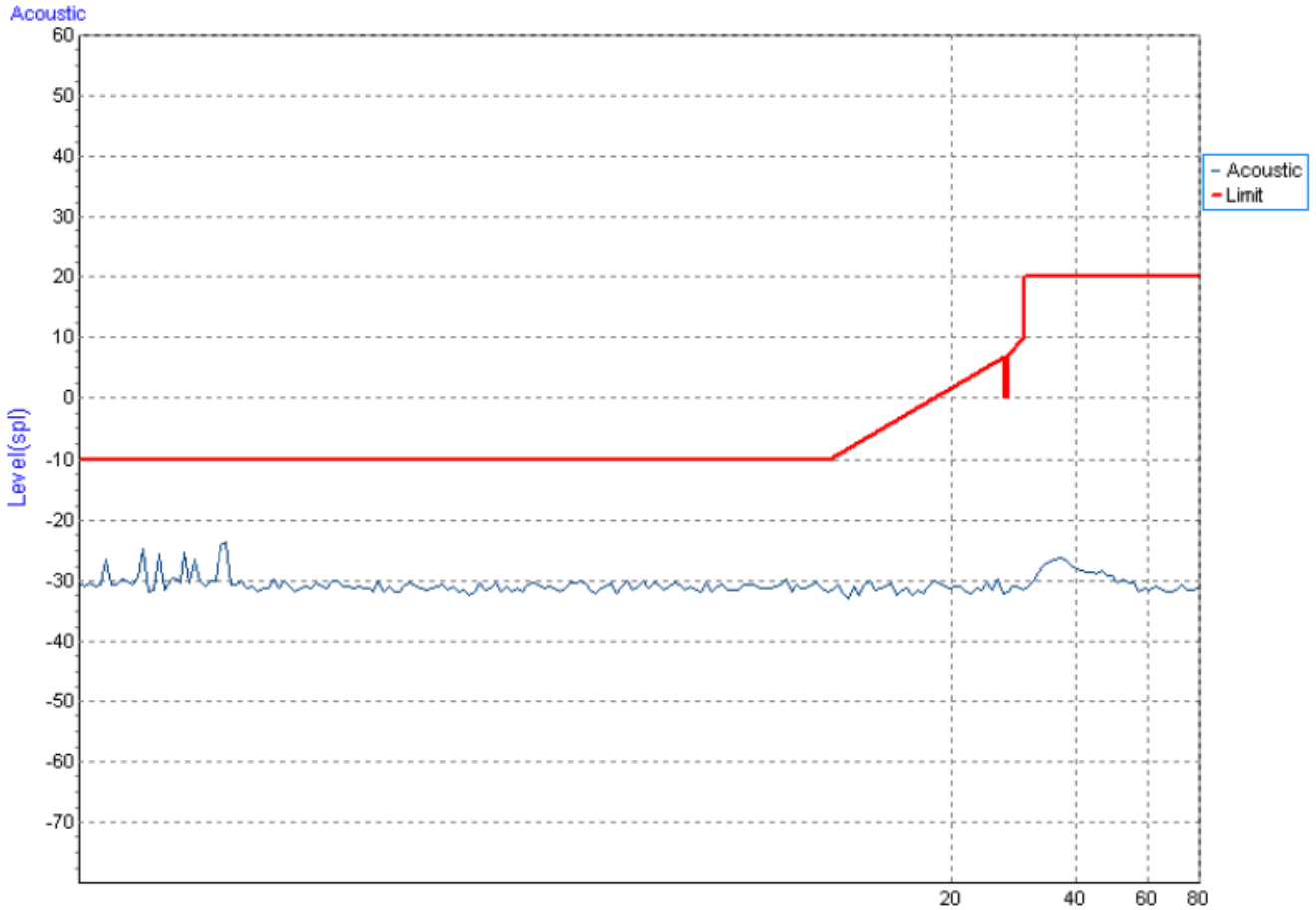

EUT	IP Phone	Model Name	E6G
Temperature	25°C	Relative Humidity	55%
Test Voltage	DC 48V		
Test Mode	Handfree		
Note	PoE, Internet Port, CDN T8		

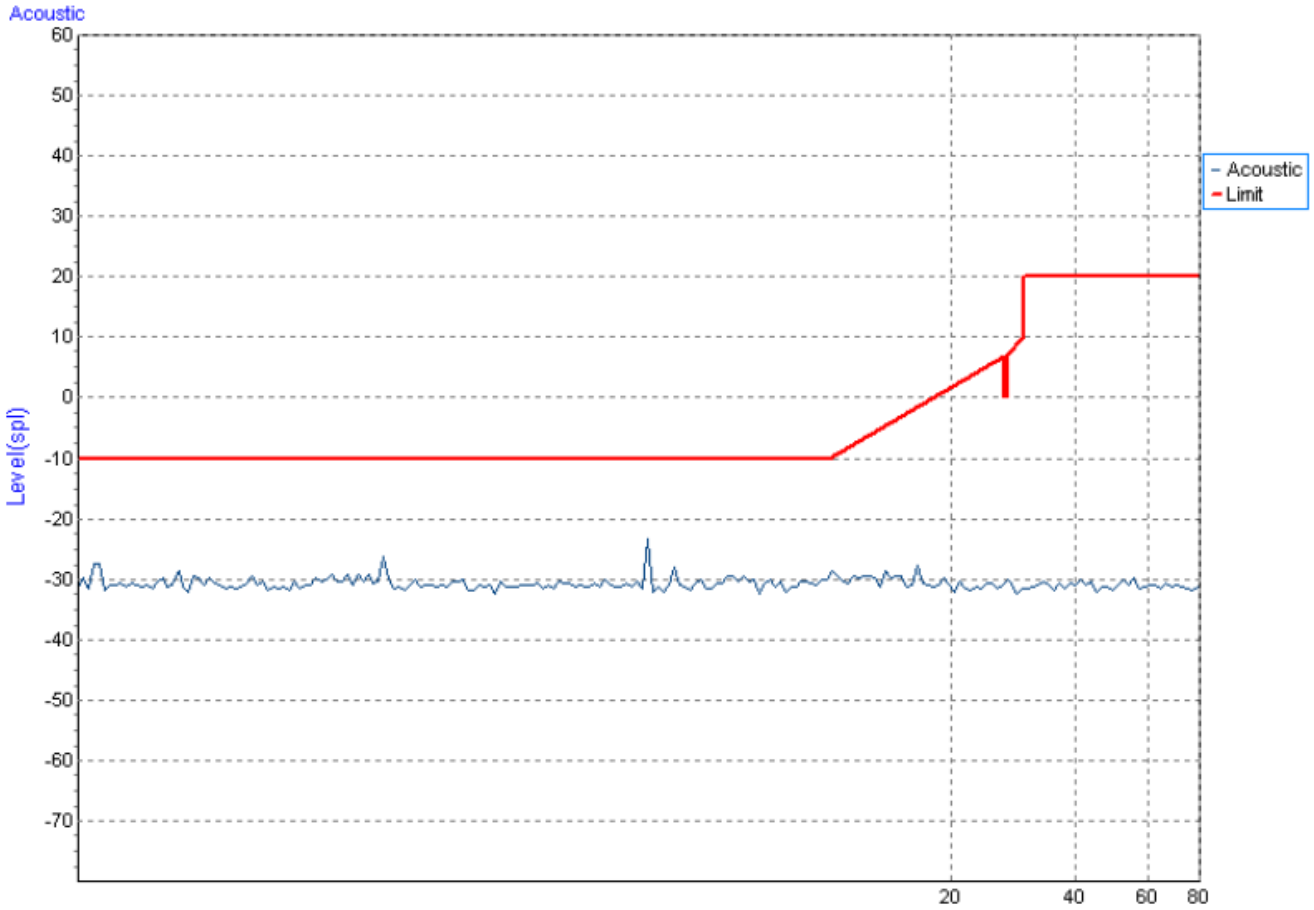

EUT	IP Phone	Model Name	E6G
Temperature	25°C	Relative Humidity	55%
Test Voltage	DC 48V		
Test Mode	Handfree		
Note	PoE, PC Port, CDN T8		

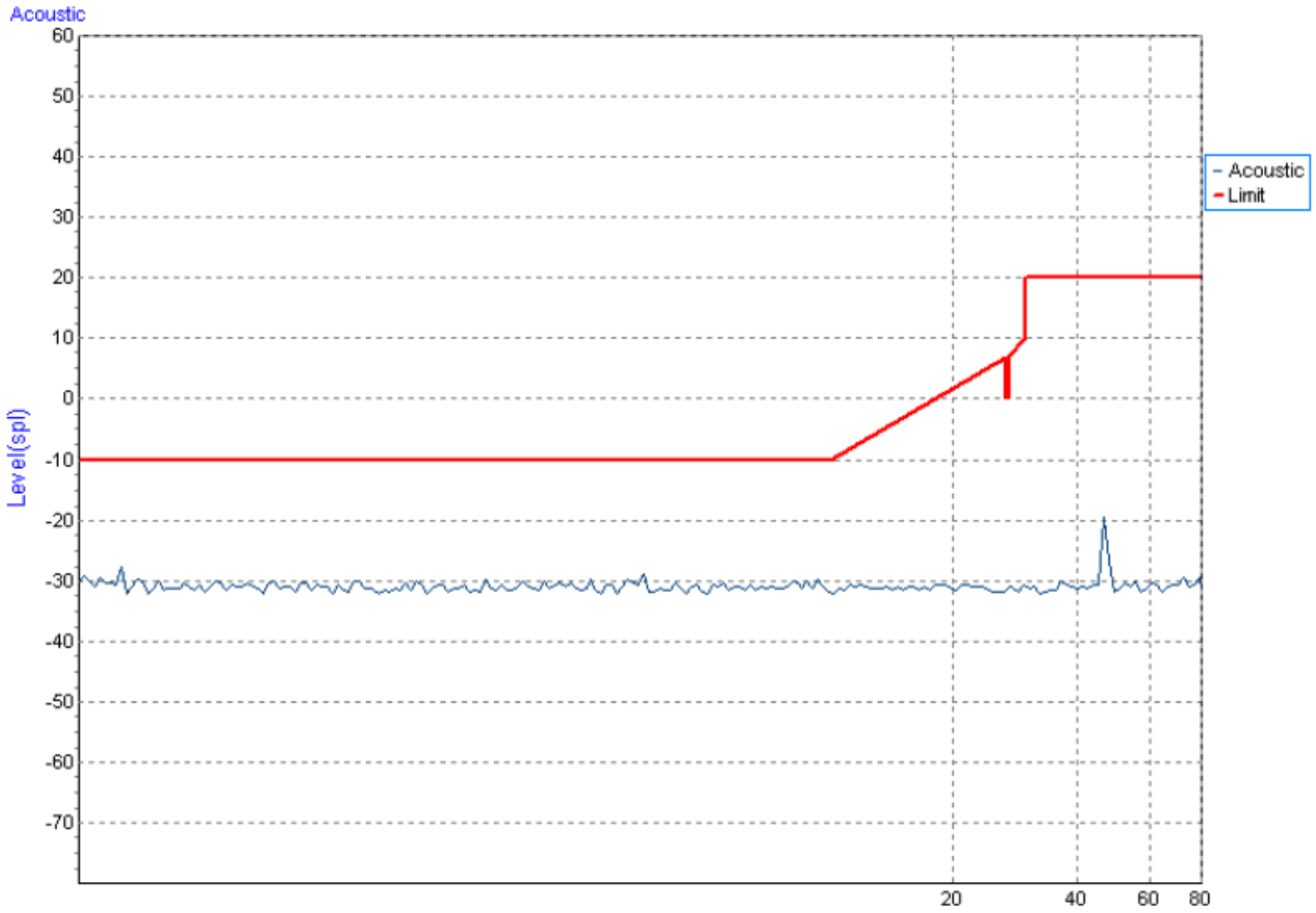

5.8 POWER FREQUENCY MAGNETIC FIELD IMMUNITY TEST (PFMF)

5.8.1 TEST SPECIFICATION

Basic Standard	EN 61000-4-8
Required Performance	A
Frequency Range	50/60 Hz
Field Strength	1 A/m
Observation Time	1 minute
Inductance Coil	Rectangular type, 1mx1m

5.8.2 MEASUREMENT INSTRUMENTS

Item	Kind of Equipment	Manufacturer	Type No.	Serial No.	Calibrated until
1	Magnetic Field test Generator	FCC	F-1000-4-8-G-125A	04032	Mar. 26, 2018
2	Magnetic Field immunity loop	Thermo KeyTek	F-1000-4-8/9/10-L-1M	04024	Mar. 26, 2018

Remark: "N/A" denotes no model name, no serial No. or no calibration specified.
All calibration period of equipment list is one year.

5.8.3 TEST PROCEDURE

The EUT and support equipment, are placed on a table that is 0.8 meter above a metal ground plane measured 1m*1m min. and 0.65mm thick min.

The other condition as following manner:

- a. The equipment cabinets shall be connected to the safety earth directly on the GRP via the earth terminal of the EUT.
- b. The cables supplied or recommended by the equipment manufacturer shall be used. 1 meter of all cables used shall be exposed to the magnetic field.

5.8.4 DEVIATION FROM TEST STANDARD

No deviation

5.8.5 TEST SETUP

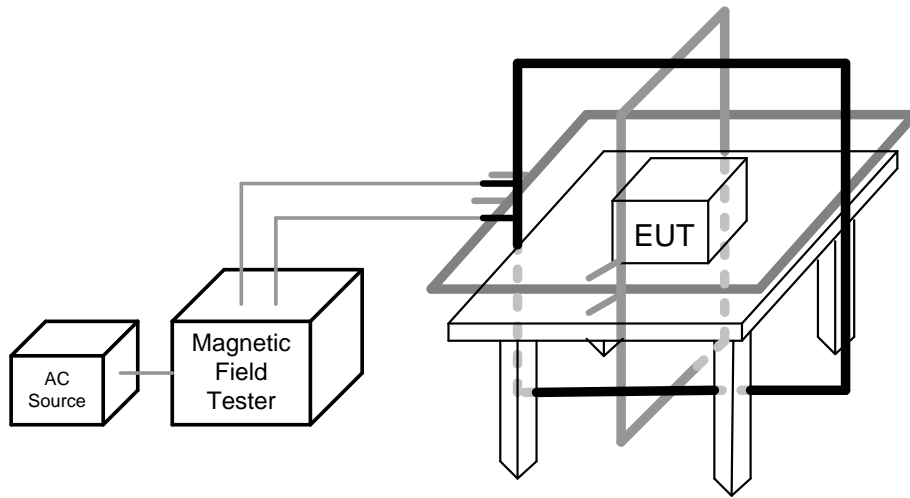

Note:

TABLE-TOP EQUIPMENT

The equipment shall be subjected to the test magnetic field by using the induction coil of standard dimension (1 m x 1 m). The induction coil shall then be rotated by 90 degrees in order to expose the EUT to the test field with different orientations.

FLOOR-STANDING EQUIPMENT

The equipment shall be subjected to the test magnetic field by using induction coils of suitable dimensions. The test shall be repeated by moving and shifting the induction coils, in order to test the whole volume of the EUT for each orthogonal direction. The test shall be repeated with the coil shifted to different positions along the side of the EUT, in steps corresponding to 50 percent of the shortest side of the coil. The induction coil shall then be rotated by 90 degrees in order to expose the EUT to the test field with different orientations.

5.8.6 TEST RESULTS

EUT	IP Phone	Model Name	E6G
Temperature	25°C	Relative Humidity	55%
Test Voltage	AC 230V/50Hz		
Test Mode	Handfree,Handset,Headphone		

50Hz

Test Mode	Test Level	Antenna aspect	Duration (s)	Criteria	Results	Judgment
Enclosure	1 A/m	X	60	A	A	PASS
Enclosure	1 A/m	Y	60	A	A	PASS
Enclosure	1 A/m	Z	60	A	A	PASS

60Hz

Test Mode	Test Level	Antenna aspect	Duration (s)	Criteria	Results	Judgment
Enclosure	1 A/m	X	60	A	A	PASS
Enclosure	1 A/m	Y	60	A	A	PASS
Enclosure	1 A/m	Z	60	A	A	PASS

Note:

- 1). N/A - denotes test is not applicable in this test report.
- 2) Criterion A: No observation of any performance degradation.
- 3) Criterion B: Some degradation of performance is observed but the equipment continues to operate as intended.
- 4) Criterion C: Loss of functionality, but self-recoverable by user, without loss of information or settings.

5.9 VOLTAGE DIPS, SHORT INTERRUPTIONS AND VOLTAGE VARIATIONS IMMUNITY TEST

5.9.1 TEST SPECIFICATION

Basic Standard	EN 61000-4-11
Required Performance	B (For >95% Voltage Dips) C (For 30% Voltage Dips) C (For >95% Voltage Interruptions)
Test Duration Time	Minimum three test events in sequence
Interval between Event	Minimum ten seconds
Phase Angle	0°/180°
Test Cycle	3 times

5.9.2 MEASUREMENT INSTRUMENTS

Item	Kind of Equipment	Manufacturer	Type No.	Serial No.	Calibrated until
1	THE MODULAR SOLUTION FOR 6 KV APPLICATIONS	Teseq	NSG 3060	1423	Aug. 20, 2018
2	Measurement Software	Teseq	Win 3000 Version 1.2.0	N/A	N/A

Remark: "N/A" denotes no model name, no serial No. or no calibration specified.

All calibration period of equipment list is one year.

5.9.3 TEST PROCEDURE

The EUT shall be tested for each selected combination of test levels and duration with a sequence of three dips/interruptions with intervals of 10 s minimum (between each test event). Each representative mode of operation shall be tested. Abrupt changes in supply voltage shall occur at zero crossings of the voltage waveform.

5.9.4 DEVIATION FROM TEST STANDARD

No deviation

5.9.5 TEST SETUP

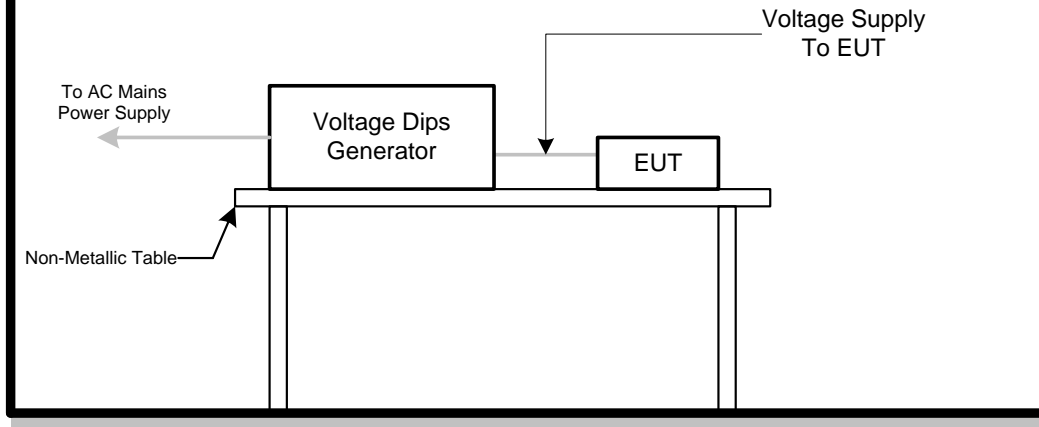

5.9.6 TEST RESULTS

EUT	IP Phone	Model Name	E6G
Temperature	25°C	Relative Humidity	55%
Test Voltage	AC 230V/50Hz		
Test Mode	Handfree,Handset,Headphone		

AC 100V/50Hz				
Voltage Reduction	Periods	Criteria	Results	Judgment
Voltage dip > 95%	0.5	B	A	PASS
Voltage dip 30%	25	C	A	PASS
Interruption > 95%	250	C	C	PASS

AC 230V/50Hz				
Voltage Reduction	Periods	Criteria	Results	Judgment
Voltage dip > 95%	0.5	B	A	PASS
Voltage dip 30%	25	C	A	PASS
Interruption > 95%	250	C	C	PASS

AC 240V/50Hz				
Voltage Reduction	Periods	Criteria	Results	Judgment
Voltage dip > 95%	0.5	B	A	PASS
Voltage dip 30%	25	C	A	PASS
Interruption > 95%	250	C	C	PASS

Note:

- 1). N/A - denotes test is not applicable in this test report.
- 2) Criterion A: No observation of any performance degradation.
- 3) Criterion B: Some degradation of performance is observed but the equipment continues to operate as intended.
- 4) Criterion C: Loss of functionality, but self-recoverable by user, without loss of information or settings.

6. EUT TEST PHOTO

Radiated emissions up to 1 GHz - Adapter

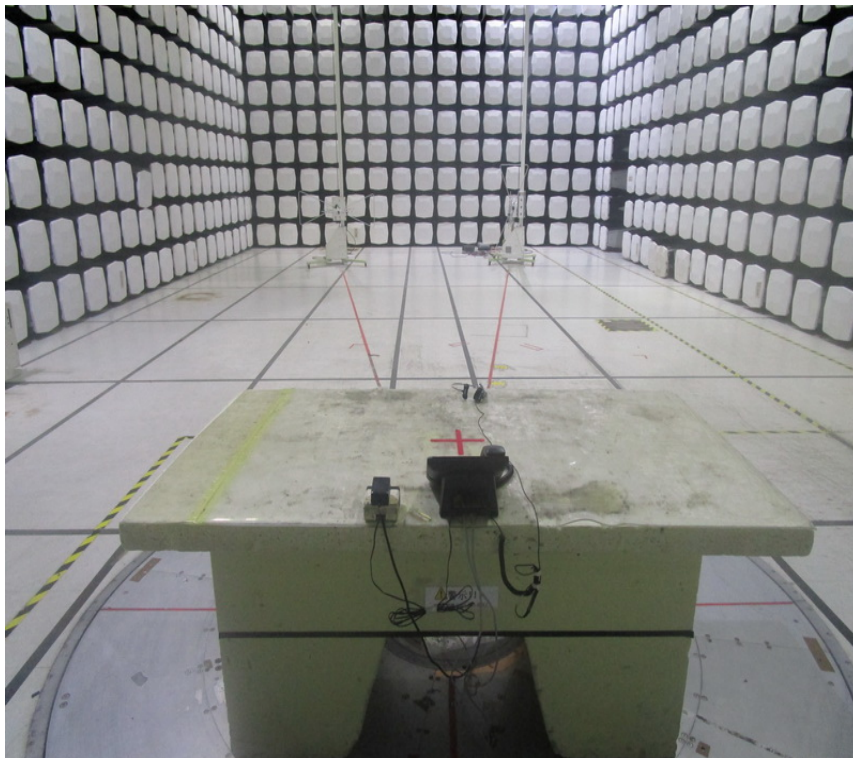
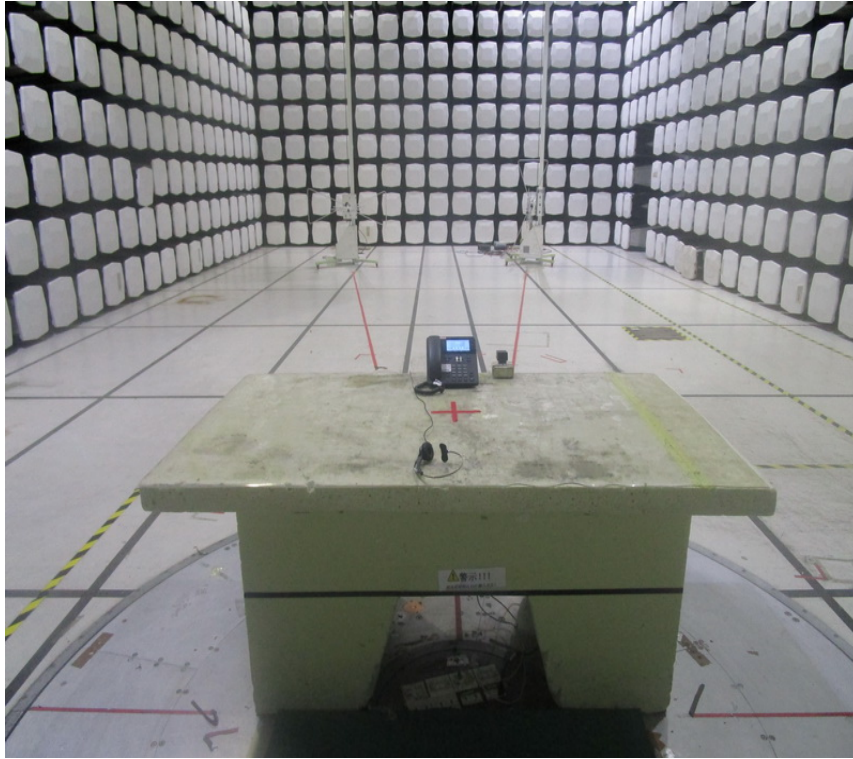

Radiated emissions up to 1 GHz - PoE

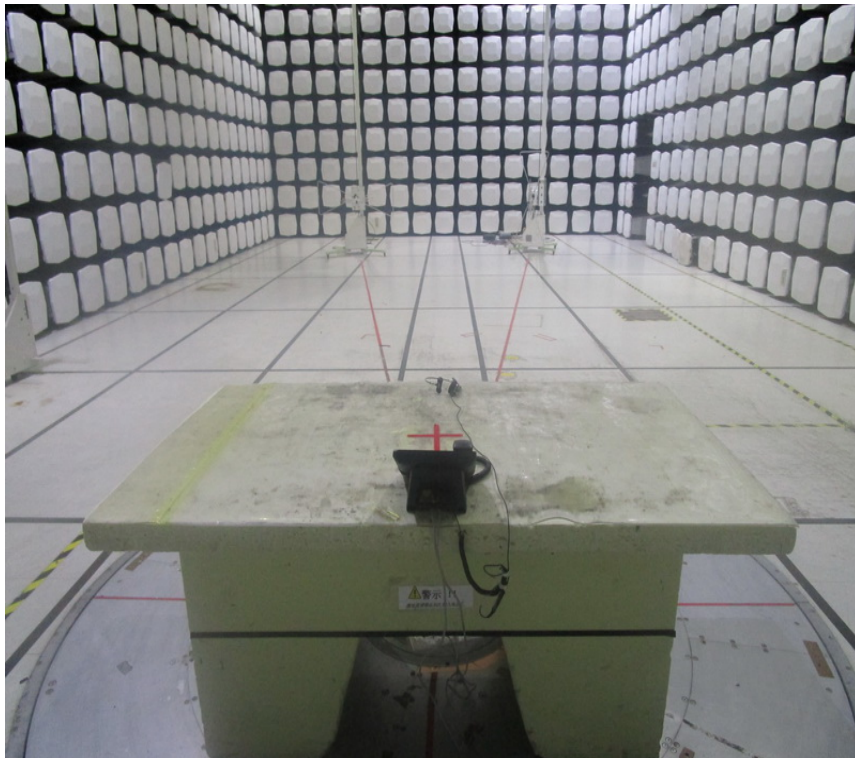
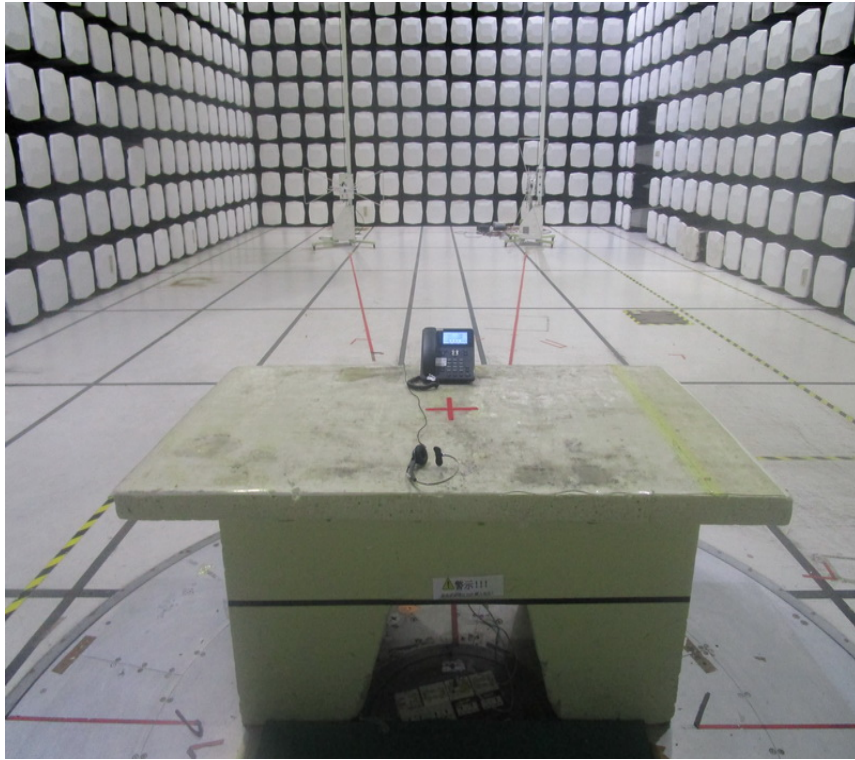

Radiated emissions above 1 GHz - Adapter

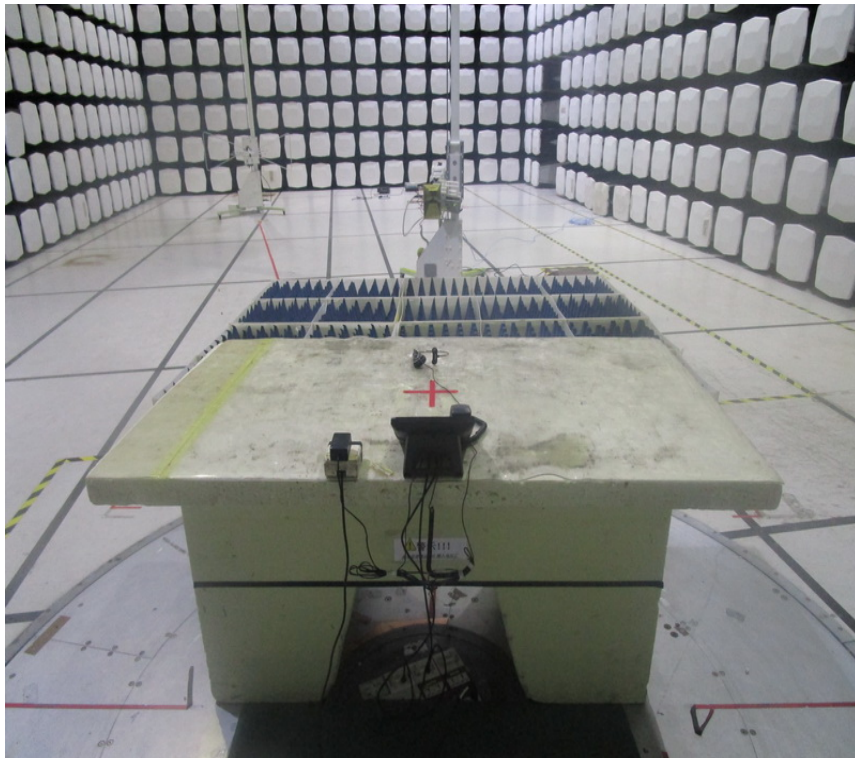
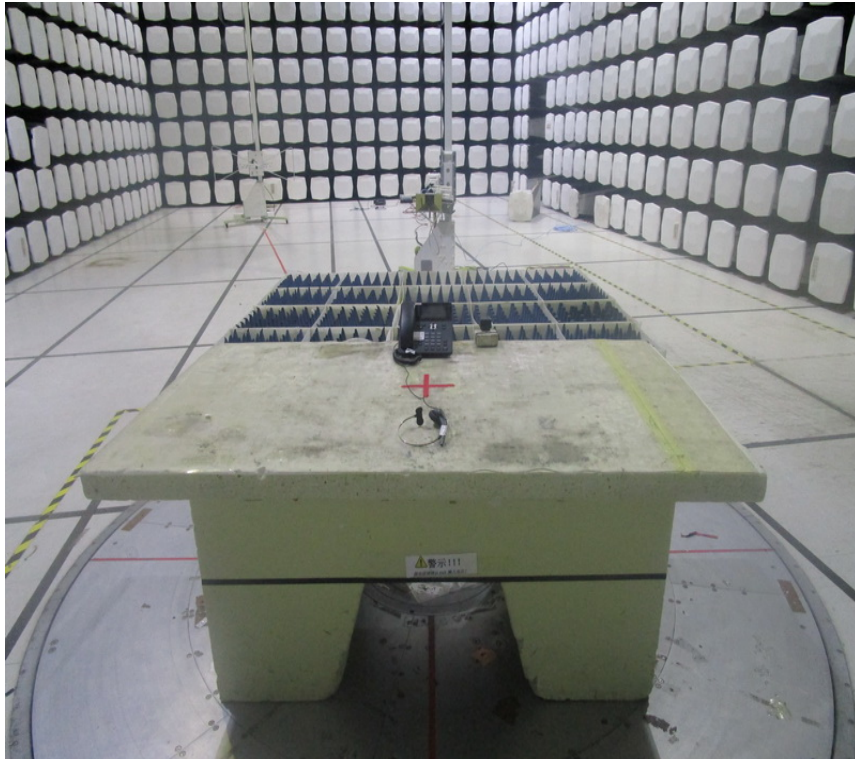

Radiated emissions above 1 GHz - PoE

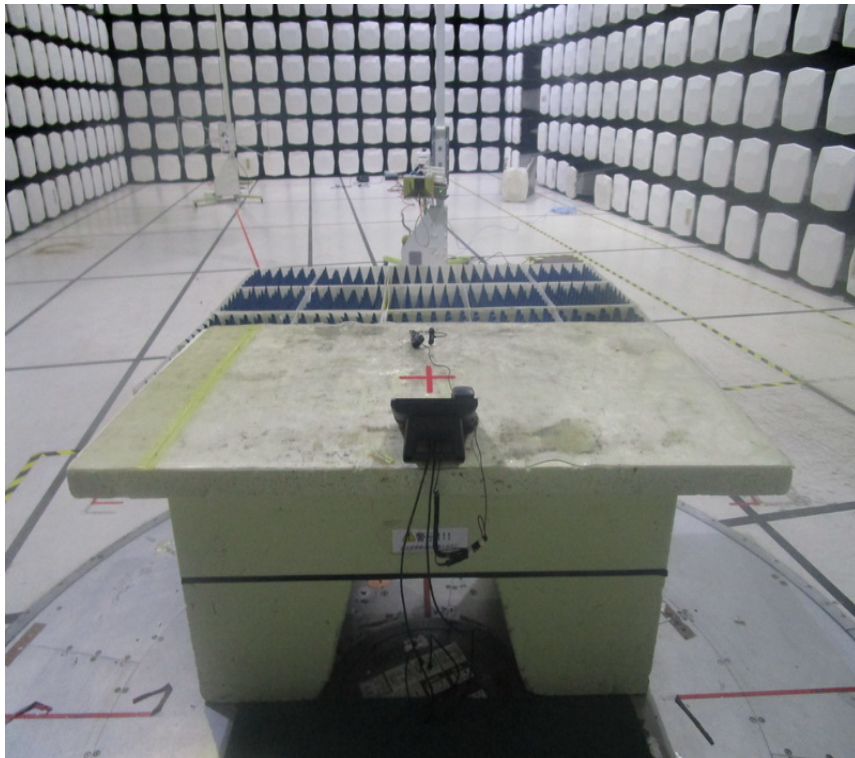
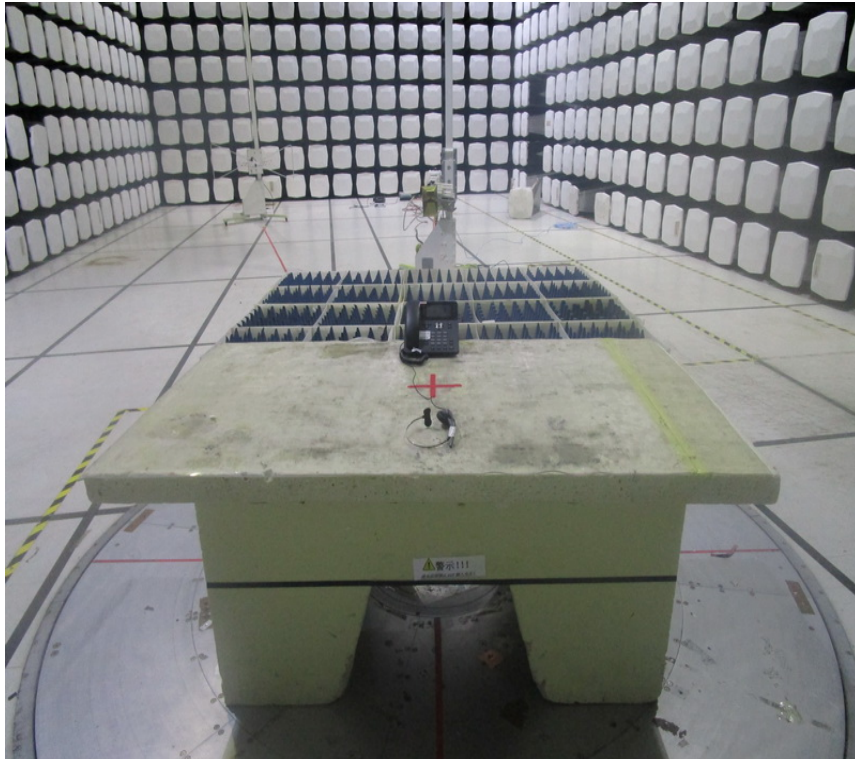

Conducted emissions AC mains power port

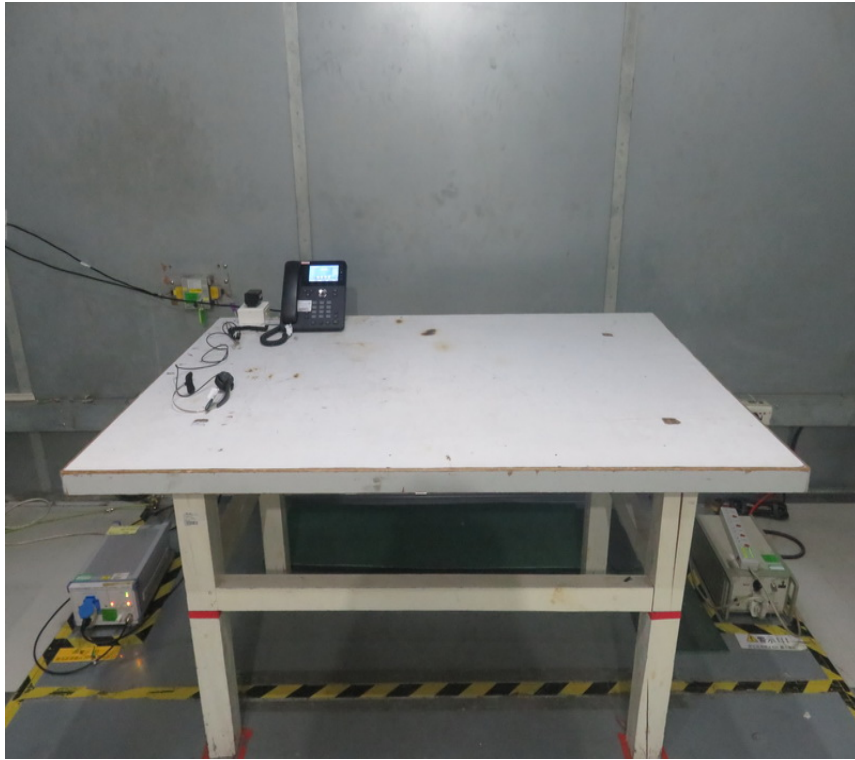

Asymmetric mode conducted emissions_AAN - Adapter

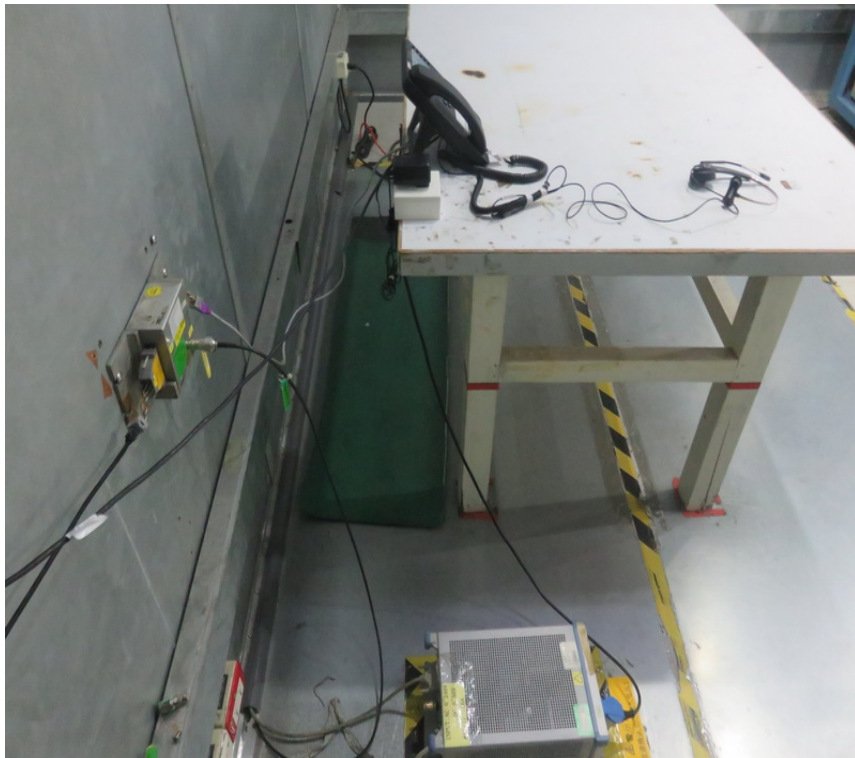
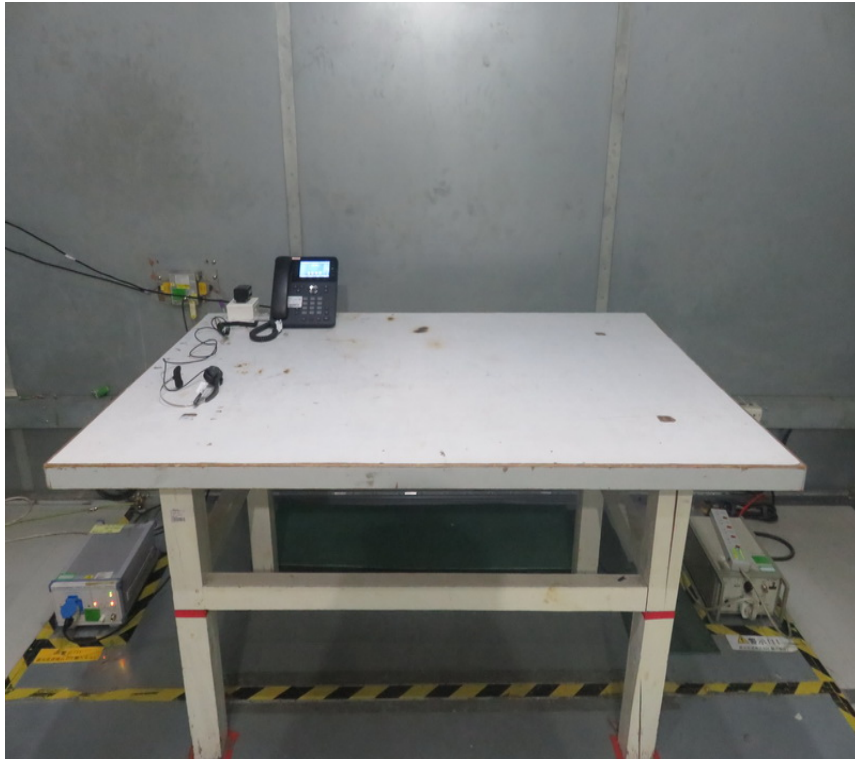

Asymmetric mode conducted emissions_AAN - PoE

