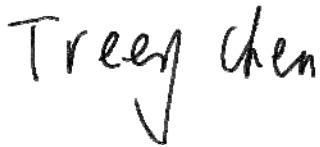

EMC Test Report

Project No. : 1610C140
Equipment : IP Phone
Test Model : F4G
Applicant : Fanvil Technology Co.Ltd
Address : 3F, Block A, Gaoxinqi Building, Anhua Industrial Park,
Qianjin 1st Rd. 35th Dist., Bao'An, Shenzhen, 518101,
China

Date of Receipt : Oct. 18, 2016
Date of Test : Oct. 18, 2016 ~ Jan. 03, 2017
Issued Date : Jan. 05, 2017
Tested by : BTL Inc.

Testing Engineer : 

(Terry Chen)

Technical Manager : 

(Bill Zhang)

Authorized Signatory : 

(Steven Lu)

B T L I N C .

No.3, Jinshagang 1st Road, Shixia, Dalang Town, Dongguan,
Guangdong, China.

TEL: +86-769-8318-3000 FAX: +86-769-8319-6000



Declaration

BTL represents to the client that testing is done in accordance with standard procedures as applicable and that test instruments used has been calibrated with standards traceable to international standard(s) and/or national standard(s).

BTL's reports apply only to the specific samples tested under conditions. It is manufacture's responsibility to ensure that additional production units of this model are manufactured with the identical electrical and mechanical components. **BTL** shall have no liability for any declarations, inferences or generalizations drawn by the client or others from **BTL** issued reports.

BTL's report must not be used by the client to claim product certification, approval, or endorsement by NVLAP, NIST, or any agency of the Federal Government.

This report is the confidential property of the client. As a mutual protection to the clients, the public and **BTL-self**, extracts from the test report shall not be reproduced except in full with **BTL's** authorized written approval.

BTL's laboratory quality assurance procedures are in compliance with the **ISO Guide 17025** requirements, and accredited by the conformity assessment authorities listed in this test report.

Limitation

For the use of the authority's logo is limited unless the Test Standard(s)/Scope(s)/Item(s) mentioned in this test report is (are) included in the conformity assessment authorities acceptance respective.

Table of Contents**Page**

REPORT ISSUED HISTORY	6
1 . CERTIFICATION	7
2 . SUMMARY OF TEST RESULTS	8
2.1 TEST FACILITY	10
2.2 MEASUREMENT UNCERTAINTY	10
3 . GENERAL INFORMATION	12
3.1 GENERAL DESCRIPTION OF EUT	12
3.2 DESCRIPTION OF TEST MODES	13
3.3 EUT OPERATING CONDITIONS	15
3.4 BLOCK DIAGRAM SHOWING THE CONFIGURATION OF SYSTEM TESTED	15
3.5 DESCRIPTION OF SUPPORT UNITS	17
4 . EMC EMISSION TEST	18
4.1 RADIATED EMISSION	18
4.1.1 LIMITS	18
4.1.2 MEASUREMENT INSTRUMENTS LIST	20
4.1.3 TEST PROCEDURE	21
4.1.4 DEVIATION FROM TEST STANDARD	22
4.1.5 TEST SETUP	22
4.1.6 MEASUREMENT DISTANCE	23
4.1.7 TEST RESULTS (UP TO 1 GHZ)	24
4.1.8 TEST RESULTS (ABOVE 1 GHZ)	36
4.2 CONDUCTED EMISSION MEASUREMENT AT AC MAINS POWER PORTS	48
4.2.1 LIMITS	48
4.2.2 MEASUREMENT INSTRUMENTS LIST	48
4.2.3 TEST PROCEDURE	49
4.2.4 DEVIATION FROM TEST STANDARD	49
4.2.5 TEST SETUP	49
4.2.6 TEST RESULTS	50
4.3 ASYMMETRIC MODE CONDUCTED EMISSIONS TEST	56
4.3.1 LIMITS	56
4.3.2 MEASUREMENT INSTRUMENTS LIST	57
4.3.3 TEST PROCEDURE	57
4.3.4 DEVIATION FROM TEST STANDARD	57
4.3.5 TEST SETUP	58
4.3.6 TEST RESULTS	59
4.4 HARMONIC CURRENT EMISSIONS TEST	67
4.4.1 LIMITS	67
4.4.2 MEASUREMENT INSTRUMENTS LIST	67

Table of Contents	Page
4.4.3 TEST PROCEDURE	68
4.4.4 DEVIATION FROM TEST STANDARD	68
4.4.5 TEST SETUP	68
4.4.6 TEST RESULTS	69
4.5 VOLTAGE CHANGES, VOLTAGE FLUCTUATIONS AND FLICKER TEST	72
4.5.1 LIMITS	72
4.5.2 MEASUREMENT INSTRUMENTS LIST	72
4.5.3 TEST PROCEDURE	72
4.5.4 DEVIATION FROM TEST STANDARD	72
4.5.5 TESTSETUP	73
4.5.6 TEST RESULTS	74
5 . EMC IMMUNITY TEST	75
5.1 STANDARD COMPLIANCE/SEVERITY LEVEL/CRITERIA	75
5.2 GENERAL PERFORMANCE CRITERIA	77
5.3 ELECTROSTATIC DISCHARGE IMMUNITY TEST (ESD)	78
5.3.1 TEST SPECIFICATION	78
5.3.2 MEASUREMENT INSTRUMENTS	78
5.3.3 TEST PROCEDURE	78
5.3.4 DEVIATION FROM TEST STANDARD	79
5.3.5 TEST SETUP	79
5.3.6 TEST RESULTS	80
5.4 RADIATED, RADIO-FREQUENCY, ELECTROMAGNETIC FIELD IMMUNITY TEST (RS)	84
5.4.1 TEST SPECIFICATION	84
5.4.2 MEASUREMENT INSTRUMENTS	84
5.4.3 TEST PROCEDURE	84
5.4.4 DEVIATION FROM TEST STANDARD	84
5.4.5 TEST SETUP	85
5.4.6 TEST RESULTS	86
5.5 ELECTRICAL FAST TRANSIENT/BURST IMMUNITY TEST (EFT/BURST)	87
5.5.1 TEST SPECIFICATION	87
5.5.2 MEASUREMENT INSTRUMENTS	87
5.5.3 TEST PROCEDURE	87
5.5.4 DEVIATION FROM TEST STANDARD	87
5.5.5 TEST SETUP	88
5.5.6 TEST RESULTS	89
5.6 SURGE IMMUNITY TEST	90
5.6.1 TEST SPECIFICATION	90
5.6.2 MEASUREMENT INSTRUMENTS	90
5.6.3 TEST PROCEDURE	91
5.6.4 DEVIATION FROM TEST STANDARD	92

Table of Contents	Page
5.6.5 TEST SETUP	92
5.6.6 TEST RESULTS	93
5.7 IMMUNITY TO CONDUCTED DISTURBANCES, INDUCED BY	
RADIO-FREQUENCY FIELDS TEST (CS)	94
5.7.1 TEST SPECIFICATION	94
5.7.2 MEASUREMENT INSTRUMENTS	94
5.7.3 TEST PROCEDURE	94
5.7.4 DEVIATION FROM TEST STANDARD	94
5.7.5 TEST SETUP	95
5.7.6 TEST RESULTS	96
5.8 POWER FREQUENCY MAGNETIC FIELD IMMUNITY TEST (PFMF)	97
5.8.1 TEST SPECIFICATION	97
5.8.2 MEASUREMENT INSTRUMENTS	97
5.8.3 TEST PROCEDURE	97
5.8.4 DEVIATION FROM TEST STANDARD	97
5.8.5 TEST SETUP	98
5.8.6 TEST RESULTS	99
5.9 VOLTAGE DIPS, SHORT INTERRUPTIONS AND VOLTAGE VARIATIONS	
IMMUNITY TEST	100
5.9.1 TEST SPECIFICATION	100
5.9.2 MEASUREMENT INSTRUMENTS	100
5.9.3 TEST PROCEDURE	100
5.9.4 DEVIATION FROM TEST STANDARD	100
5.9.5 TEST SETUP	101
5.9.6 TEST RESULTS	102

REPORT ISSUED HISTORY

Issued No.	Description	Issued Date
BTL-EMC-1-1610C140	Original Issue.	Jan. 05, 2017

1. CERTIFICATION

Equipment : IP Phone
Brand Name : Fanvil
Test Model : F4G
Applicant : Fanvil Technology Co.Ltd
Date of Test : Oct. 18, 2016 ~ Jan. 03, 2017
Test Sample : Engineering Sample
Standard(s) : EN 55032: 2012+AC:2013 Class B
EN 61000-3-2: 2014 Class A
EN 61000-3-3: 2013
EN 55024: 2010+A1:2015
EN 61000-4-2: 2009
EN 61000-4-3: 2006+A1:2008+A2:2010
EN 61000-4-4: 2012
EN 61000-4-5: 2014
EN 61000-4-6: 2014+AC : 2015
EN 61000-4-8: 2010
EN 61000-4-11: 2004

The above equipment has been tested and found compliance with the requirement of the relative standards by BTL Inc.

The test data, data evaluation, and equipment configuration contained in our test report (Ref No. BTL-EMC-1-1610C140) were obtained utilizing the test procedures, test instruments, test sites that has been accredited by the Authority of TAF according to the ISO-17025 quality assessment standard and technical standard(s).

2. SUMMARY OF TEST RESULTS

Test procedures according to the technical standards:

Emission					
Standard(s)	Test Item	Limit	Judgment	Remark	
EN 55032: 2012+AC:2013	Radiated emissions up to 1 GHz	Class B	PASS	-----	
	Radiated emissions above 1 GHz	Class B	PASS	NOTE (2)	
	Radiated emissions from FM receivers	-----	N/A	NOTE (1) NOTE (6)	
	Conducted emissions AC mains power port	Class B	PASS	NOTE (7)	
	Asymmetric mode conducted emissions	AAN	-----	PASS	NOTE (1) NOTE (8)
		Current Probe	-----	N/A	
		CVP	-----	N/A	
Conducted differential voltage emissions	-----	N/A	NOTE (1) NOTE (9)		

Standard	Test Item	Limit	Judgment	Remark
EN 61000-3-2:2014	Harmonic current emissions	Class A	PASS	NOTE (3)
EN 61000-3-3:2013	Voltage changes, voltage fluctuations and flicker		PASS	

Immunity EN 55024: 2010+A1:2015				
Section(s)	Test Item	Performance Criterion	Judgment	Remark
EN 61000-4-2:2009	Electrostatic discharge immunity	B	PASS	
EN 61000-4-3: 2006+A1:2008+A2:2010	Radiated, radio-frequency, electromagnetic field immunity	A	PASS	
EN 61000-4-4:2012	Electrical fast transient/burst immunity	B	PASS	
EN 61000-4-5:2014	Surge immunity	B/C	PASS	NOTE (4)
EN 61000-4-6: 2014+AC :2015	Immunity to conducted disturbances, induced by radio-frequency fields	A	PASS	
EN 61000-4-8:2010	Power frequency magnetic field immunity	A	PASS	
EN 61000-4-11:2004	Voltage dips, short interruptions and voltage variations immunity	B / C / C	PASS	NOTE (5)

NOTE:

- (1) "N/A" denotes test is not applicable to this device.
- (2) The EUT's max operating frequency is 166 MHz which does exceed 108 MHz, so the test will be performed.
- (3) If the power consumption is less than 75W, there is no limit applied.
- (4) Performance Criterion C for signal ports and telecommunication ports.
Performance Criterion B for input d.c. power port and a.c. power ports.
- (5) Voltage Dips: >95% reduction – Performance Criterion B
Voltage Dips: 30% reduction – Performance Criterion C
Voltage Interruptions: >95% reduction – Performance Criterion C
- (6) If the EUT has FM function the test will be performed.
- (7) If the EUT has AC power mains port the test will be performed.
- (8)

Cable Type	Number of pairs	Measurement type	Procedures
Balanced Unscreened	1 (2 wire) :2 (4 wire): 3 (6 wire) :4 (8 wire)	Voltage	AAN
Balanced Unscreened	See a)	Voltage and Current	CP+CVP
Screened or Coaxial	n/a	Voltage	AAN
Screened or Coaxial	n/a	Voltage or Current	CP or CVP
Unbalanced cables	n/a	Voltage and Current	CP+CVP

Ports connected to cables with more than 4 balanced pairs or where the port is unable to function correctly when connected through an AAN.

- (9) If the EUT has tuner port the test will be performed.
- (10)The requirement followed by the client's specification.

2.1 TEST FACILITY

The test facilities used to collect the test data in this report is at the location of No.3, Jinshagang 1st Road, Shixia, Dalang Town, Dongguan, Guangdong, China.

2.2 MEASUREMENT UNCERTAINTY

Where relevant, the following measurement uncertainty levels have been estimated for tests performed on the EUT as specified in CISPR 16-4-2, The BTL measurement uncertainty is less than the CISPR 16-4-2 U_{CISPR} requirement.

The reported uncertainty of measurement $y \pm U$, where expanded uncertainty U is based on a standard uncertainty multiplied by a coverage factor of $k=2$, providing a level of confidence of approximately **95%**.

A. Conducted emissions AC mains power port measurement:

Test Site	Method	Measurement Frequency Range	U, (dB)
DG-C01	CISPR	150 kHz ~ 30MHz	3.16

B. Conducted disturbance at telecommunication port measurement:

Test Site	Method	Measurement Frequency Range	U, (dB)
DG-C01	CISPR	ISN 50...40dB	3.76
		ISN 65...50dB	3.76
		ISN 75...60dB	3.76
		Capacitive Voltage Probe	3.04
		RF Current Probe	2.58

C. Radiated emissions up to 1 GHz measurement:

Test Site	Method	Measurement Frequency Range	Ant. H / V	U, (dB)
DG-CB08 (10m)	CISPR	30MHz ~ 200MHz	V	4.66
		30MHz ~ 200MHz	H	4.64
		200MHz ~ 1,000MHz	V	4.88
		200MHz ~ 1,000MHz	H	4.86

D. Radiated emissions above 1 GHz measurement:

Test Site	Method	Measurement Frequency Range	U, (dB)
DG-CB08 (3m)	CISPR	1 ~ 6 GHz	4.26
		6 ~ 18 GHz	5.30

E. Harmonic current emissions / Voltage changes, voltage fluctuations and flicker measurement:

Test Site	Method	Measurement Frequency Range	U, (dB)
DG-C01	EN 61000-3-2	Voltage	0.774
	EN 61000-3-3	Current	0.782

F. Immunity Measurement:

Test Site	Method	Measurement Frequency Range	U, (dB)
DG-SR02	EN 61000-4-2	Voltage(2kV/4kV/6kV/8kV/15kV/25kV/30kV)	1.0%
		Peak Current	6.0%
		30/60ns Current	6.0%
		Rise time	6.4%
DG-CB05	EN 61000-4-3	80MHz~1GHz	2.175 dB
		1GHz~6GHz	2.175 dB
DG-SR05	EN 61000-4-4	Impulse Voltage	4.0 %
		Impulse Rise Time	4.5 %
		Impulse duration Time	4.0 %
DG-SR05	EN 61000-4-5	Impulse Voltage	4.0 %
		Impulse Rise Time	4.5 %
		Impulse duration Time	4.0 %
DG-CB06	EN 61000-4-6	CDN: 150kHz~230MHz	2.509 dB
		EM Clamp: 150kHz~230MHz	3.094 dB
DG-SR05	EN 61000-4-8	Magnetic Field Level	3 %
DG-SR05	EN 61000-4-11	Impulse Amplitude	4 %
		Timing	3 %

Note: Unless specifically mentioned, the uncertainty of measurement has not been taken into account to declare the compliance or non-compliance to the specification.

3. GENERAL INFORMATION

3.1 GENERAL DESCRIPTION OF EUT

Equipment	IP Phone
Brand Name	Fanvil
Test Model	F4G
Model Difference	N/A
Power Source	1# DC voltage supplied from AC/DC adapter. Manufacturer: SHENZHEN FRECOM ELECTRONICS CO.,LTD. Model: F05L5-050100SPAVL.P.S. 2# PoE supplied.
Power Rating	1# I/P: 100-240V~ 50/60Hz 0.2A O/P:5V---1A 2# PoE 48V

Note:

1. For a more detailed features description, please refer to the manufacturer's specifications or the user's manual.

3.2 DESCRIPTION OF TEST MODES

To investigate the maximum EMI emission characteristics generates from EUT, the test system was pre-scanning tested base on the consideration of following EUT operation mode or test configuration mode which possible have effect on EMI emission level. Each of these EUT operation mode(s) or test configuration mode(s) mentioned above was evaluated respectively.

Pretest Mode	Description
Mode 1	Adapter Supply:Handfree
Mode 2	Adapter Supply:Handset
Mode 3	Adapter Supply:Earphone
Mode 4	PoE Supply:Handfree
Mode 5	PoE Supply:Handset
Mode 6	PoE Supply:Earphone
Mode 7	Adapter Supply:WAN 100Mbps
Mode 8	Adapter Supply:WAN 10Mbps
Mode 9	Adapter Supply:LAN 100Mbps
Mode 10	Adapter Supply:LAN 10Mbps
Mode 11	PoE Supply:WAN 100Mbps
Mode 12	PoE Supply:WAN 10Mbps
Mode 13	PoE Supply:LAN 100Mbps
Mode 14	PoE Supply:LAN 10Mbps

For Radiated Test	
Final Test Mode	Description
Mode 1	Adapter Supply:Handfree
Mode 2	Adapter Supply:Handset
Mode 3	Adapter Supply:Earphone
Mode 4	PoE Supply:Handfree
Mode 5	PoE Supply:Handset
Mode 6	PoE Supply:Earphone

For Conducted Test	
Final Test Mode	Description
Mode 1	Adapter Supply:Handfree
Mode 2	Adapter Supply:Handset
Mode 3	Adapter Supply:Earphone
Mode 4	PoE Supply:Handfree
Mode 5	PoE Supply:Handset
Mode 6	PoE Supply:Earphone

For ISN Test	
Final Test Mode	Description
Mode 7	Adapter Supply:WAN 100Mbps
Mode 8	Adapter Supply:WAN 10Mbps
Mode 9	Adapter Supply:LAN 100Mbps
Mode 10	Adapter Supply:LAN 10Mbps
Mode 11	PoE Supply:WAN 100Mbps
Mode 12	PoE Supply:WAN 10Mbps
Mode 13	PoE Supply:LAN 100Mbps
Mode 14	PoE Supply:LAN 10Mbps

For Harmonics / Flicks Test	
Final Test Mode	Description
Mode 1	Adapter Supply:Handfree

For EMS Test	
Final Test Mode	Description
Mode 1	Adapter Supply:Handfree
Mode 2	Adapter Supply:Handset
Mode 3	Adapter Supply:Earphone
Mode 4	PoE Supply:Handfree
Mode 5	PoE Supply:Handset
Mode 6	PoE Supply:Earphone

3.3 EUT OPERATING CONDITIONS

The EUT exercise program used during radiated and/or conducted emission measurement was designed to exercise the various system components in a manner similar to a typical use.

3.4 BLOCK DIAGRAM SHOWING THE CONFIGURATION OF SYSTEM TESTED

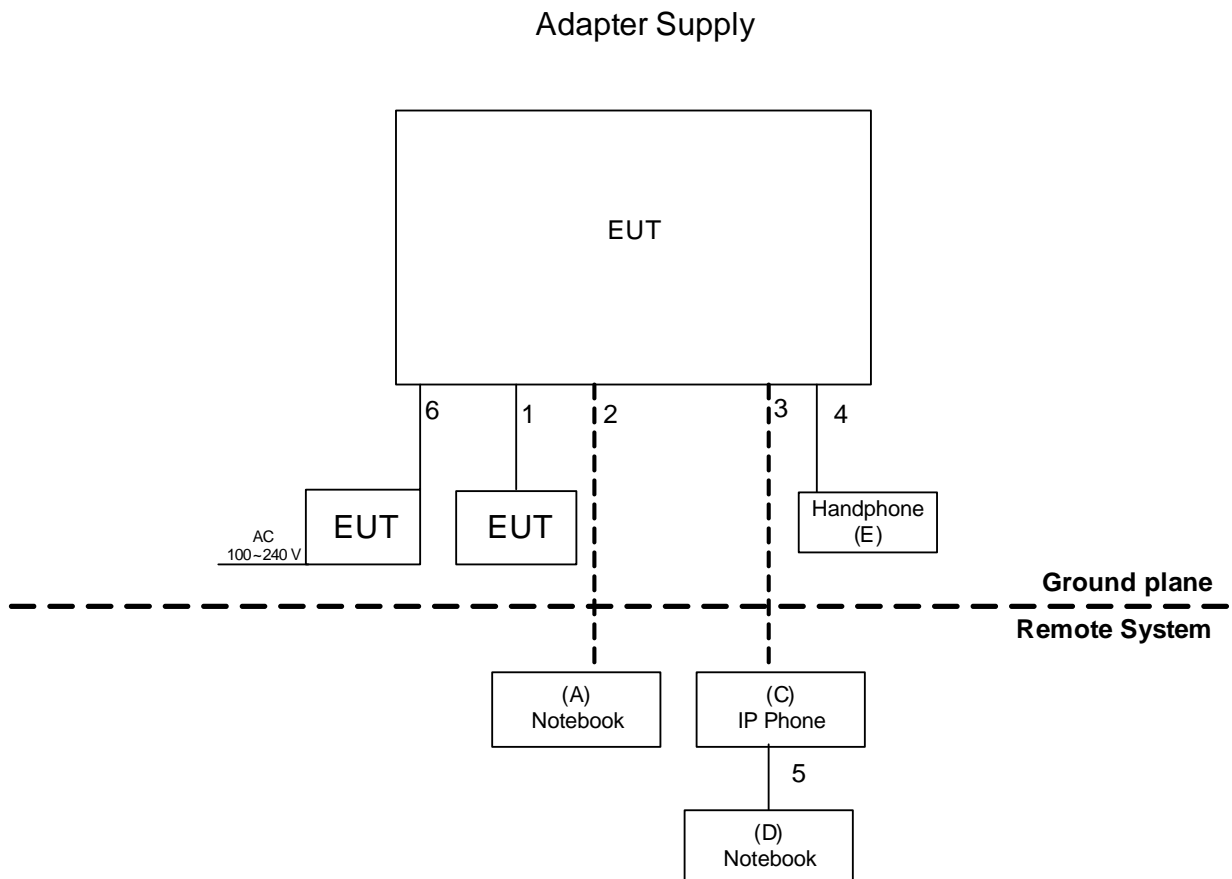

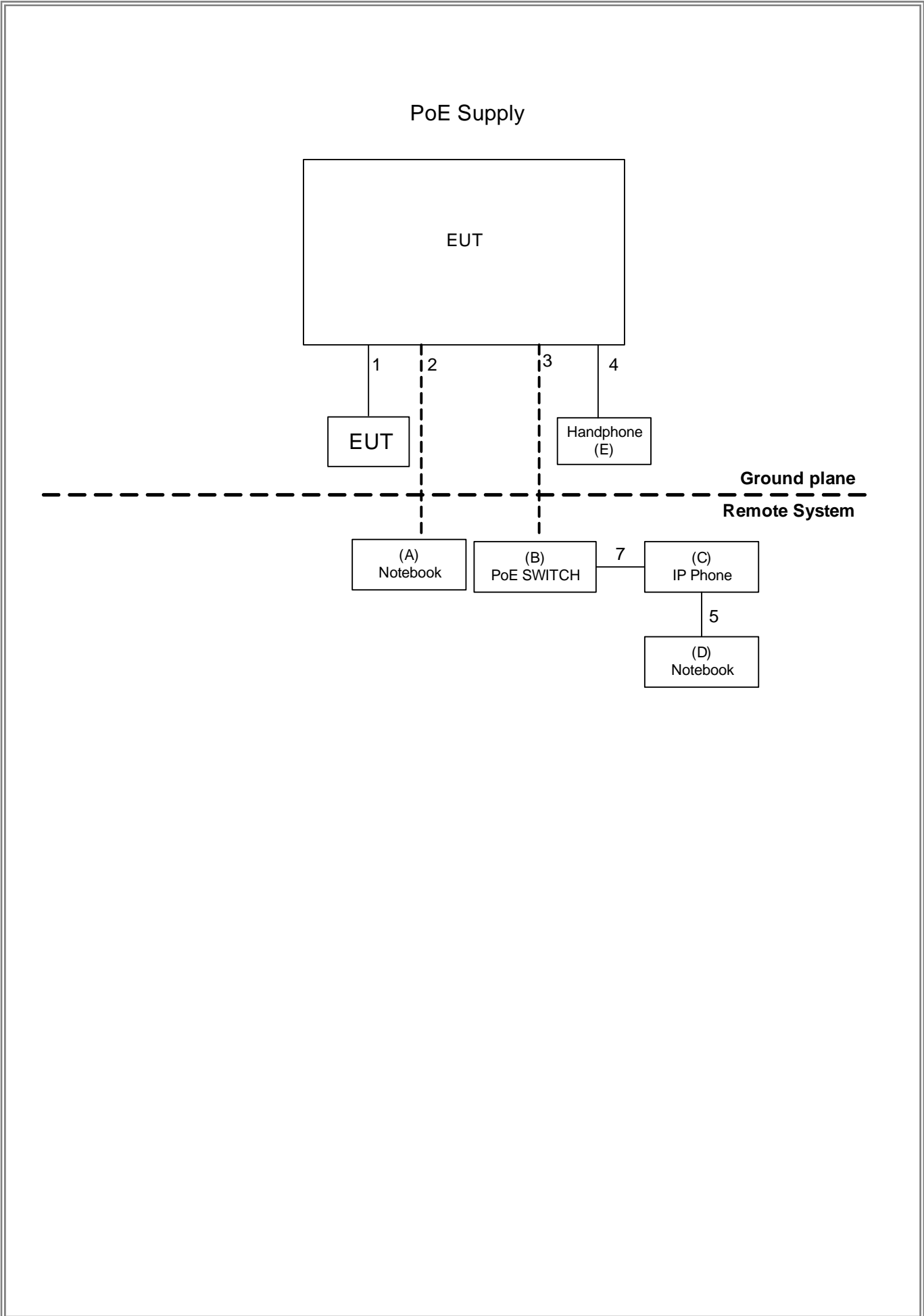

3.5 DESCRIPTION OF SUPPORT UNITS

The EUT has been tested as an independent unit together with other necessary accessories or support units. The following support units or accessories were used to form a representative test configuration during the tests.

Item	Equipment	Mfr/Brand	Model/Type No.	FCC ID	Series No.
A	PoE SWITCH	D-LINK	DGS-1008P	N/A	QB842D1000045
B	IP PHONE	FANVIL	F4G	N/A	915 HO6168000446
C	Notebook	HP	8460P	N/A	CNU1301BJ3
D	Notebook	DELL	INSPIRON 1420	N/A	JX193A01SDC2
E	Handphone	FANVIL	N/A	N/A	N/A

Item	Shielded Type	Ferrite Core	Length	Note
1	NO	NO	1.8m	RJ11 Cable
2	NO	NO	15m	RJ45 Cable
3	NO	NO	15m	RJ45 Cable
4	NO	NO	3m	Audio Cable
5	NO	NO	1m	RJ45 Cable
6	NO	NO	1.8m	DC Cable
7	NO	NO	1m	RJ45 Cable

4. EMC EMISSION TEST

4.1 RADIATED EMISSION

4.1.1 LIMITS

Class A equipment up to 1000MHz

Table clause	Frequency MHz	Measurement		Class A limit dB(uV/m)
		Distance m	Detector type/bandwidth	OATS/SAC
A2.1	30-230	10	Quasi peak / 120 kHz	40
	230-1000			47
A2.2	30-230	3		50
	230-1000			57

Class A equipment above 1000MHz

Table clause	Frequency MHz	Measurement		Class A limit dB(uV/m)
		Distance m	Detector type/bandwidth	FSOATS
A3.1	1000-3000	3	Average / 1 MHz	56
	3000-6000			60
A3.2	1000-3000		Peak / 1 MHz	76
	3000-6000			80

Class B equipment up to 1000MHz

Table clause	Frequency MHz	Measurement		Class B limit dB(uV/m)
		Distance m	Detector type/bandwidth	OATS/SAC
A4.1	30-230	10	Quasi peak / 120 kHz	30
	230-1000			37
A4.2	30-230	3		40
	230-1000			47

Class B equipment above 1000MHz

Table clause	Frequency MHz	Measurement		Class B limit dB(uV/m)
		Distance m	Detector type/bandwidth	FSOATS
A5.1	1000-3000	3	Average / 1 MHz	50
	3000-6000			54
A5.2	1000-3000		Peak / 1 MHz	70
	3000-6000			74

Notes:

- (1) The limit for radiated test was performed according to as following: EN 55032
- (2) The tighter limit applies at the band edges.
- (3) Emission level (dBuV/m)=20log Emission level (uV/m).
- (4) The test result calculated as following:
 Measurement Value = Reading Level + Correct Factor
 Correct Factor = Antenna Factor + Cable Loss - Amplifier Gain(if use)
 Margin Level = Measurement Value - Limit Value

Required highest frequency for radiated measurement

Highest internal frequency (F _x) MHz	Highest measured frequency MHz
F _x ≤ 108	1000
108 < F _x ≤ 500	2000
500 < F _x ≤ 1000	5000
F _x > 1000	5 th up to a maximum 6 GHz,

Note for FM and TV broadcast receiver, F_x is determined from the highest frequency generated or used excluding the local oscillator and tuned frequencies.

4.1.2 MEASUREMENT INSTRUMENTS LIST

Up to 1GHz:

Item	Kind of Equipment	Manufacturer	Type No.	Serial No.	Calibrated until
1	Receiver	Keysight	N9038A	MY5445000 4	Sep. 04, 2017
2	Pre-Amplifier	Mini-Circuits	EMC 9135	980284	Mar. 27, 2017
3	Pre-Amplifier	Mini-Circuits	EMC 9135	980283	Mar. 27, 2017
4	Trilog-Broadband Antenna	Schwarzbeck	VULB9168	586	Feb. 04, 2017
5	Trilog-Broadband Antenna	Schwarzbeck	VULB9168	587	Jan. 26, 2017
6	Cable	emci	LMR-400(5 m+11m+15 m)	N/A	Dec. 30, 2017
7	Cable	emci	LMR-400(5 m+8m+15 m)	N/A	Dec. 30, 2017
8	Measurement Software	Farad	EZ-EMC Ver.BTL-2A NT-1	N/A	N/A
9	Multi-Device Controller	ETS-Lindgren	2090	N/A	N/A

Remark: "N/A" denotes no model name, no serial no. or no calibration specified.
All calibration period of equipment list is one year.

Above 1GHz:

Item	Kind of Equipment	Manufacturer	Type No.	Serial No.	Calibrated until
1	Horn Antenna	EMCO	3115	9605-4803	Mar. 27, 2017
2	Amplifier	Agilent	8449B	3008A02584	Sep. 04, 2017
3	MXE EMI Receiver	Agilent	N9038A	MY5322013 3	Jun. 23, 2017
4	Measurement Software	Farad	EZ-EMC Ver.BTL-2A NT-1	N/A	N/A
5	Cable	emci	SUCOFLE X_15m_5m (0.01GHz – 26.5GHz)	N/A	Dec. 30, 2017
6	Multi-Device Controller	ETS-Lindgren	2090	N/A	N/A
7	Cable	emci	SUCOFLE X 102_8m(0. 01GHz – 40GHz)	N/A	Mar. 27, 2017

Remark: "N/A" denotes no model name, no serial no. or no calibration specified.
All calibration period of equipment list is one year.

4.1.3 TEST PROCEDURE

- a. The measuring distance of 10 m shall be used for measurements. The EUT was placed on the top of a rotating table 0.8 meter above the ground at a 10 meter semi-anechoic chamber. The table was rotated 360 degrees to determine the position of the highest radiation.(below 1GHz).
- b. The measuring distance of 3 m shall be used for measurements. The EUT was placed on the top of a rotating table 0.8 meter above the ground at a 10 meter semi-anechoic chamber. The table was rotated 360 degrees to determine the position of the highest radiation.(above 1GHz)
- c. The height of the equipment or of the substitution antenna shall be 0.8 m, the height of the test antenna shall vary between 1 m to 4 m. Both horizontal and vertical polarizations of the antenna are set to make the measurement.
- d. The initial step in collecting radiated emission data is a receiver peak detector mode pre-scanning the measurement frequency range. Significant peaks are then marked and then Quasi Peak detector mode re-measured.
- e. All readings are Peak unless otherwise stated QP in column of Note. Peak denotes that the Peak reading compliance with the QP Limits and then QP Mode measurement didn't perform. (below 1GHz)
- f. All readings are Peak Mode value unless otherwise stated AVG in column of Note. If the Peak Mode Measured value compliance with the Peak Limits and lower than AVG Limits, the EUT shall be deemed to meet both Peak & AVG Limits and then only Peak Mode was measured, but AVG Mode didn't perform. (above 1GHz)
- g. For the actual test configuration, please refer to the related Item - Block Diagram of system tested (please refer to 3.3).

4.1.4 DEVIATION FROM TEST STANDARD

No deviation

4.1.5 TEST SETUP

UP TO 1 GHZ

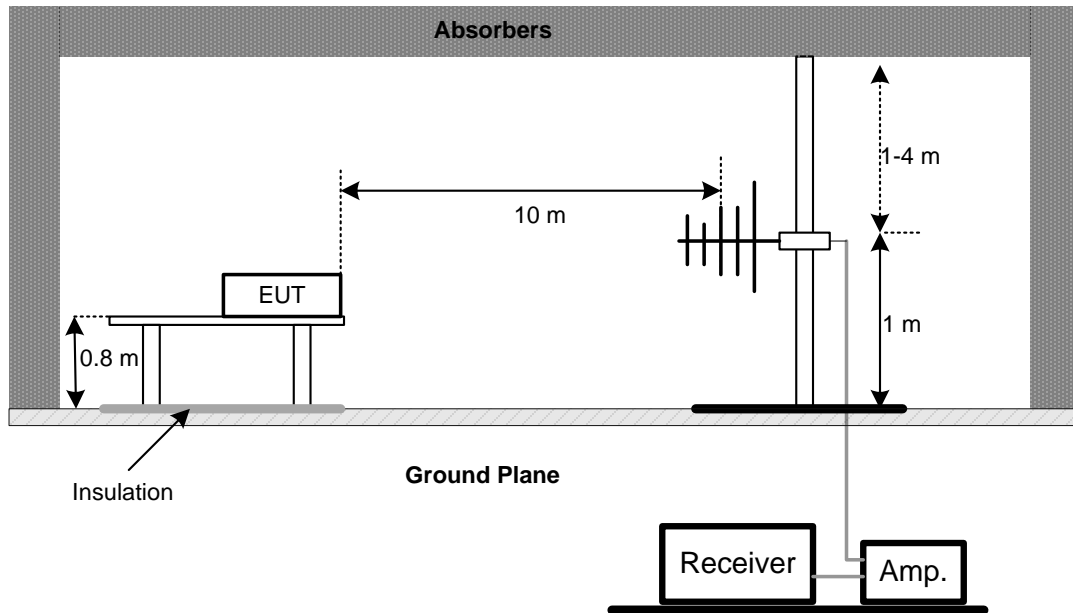

Note: The antenna can be moved between 1 to 4 meters above the ground.

ABOVE 1 GHZ

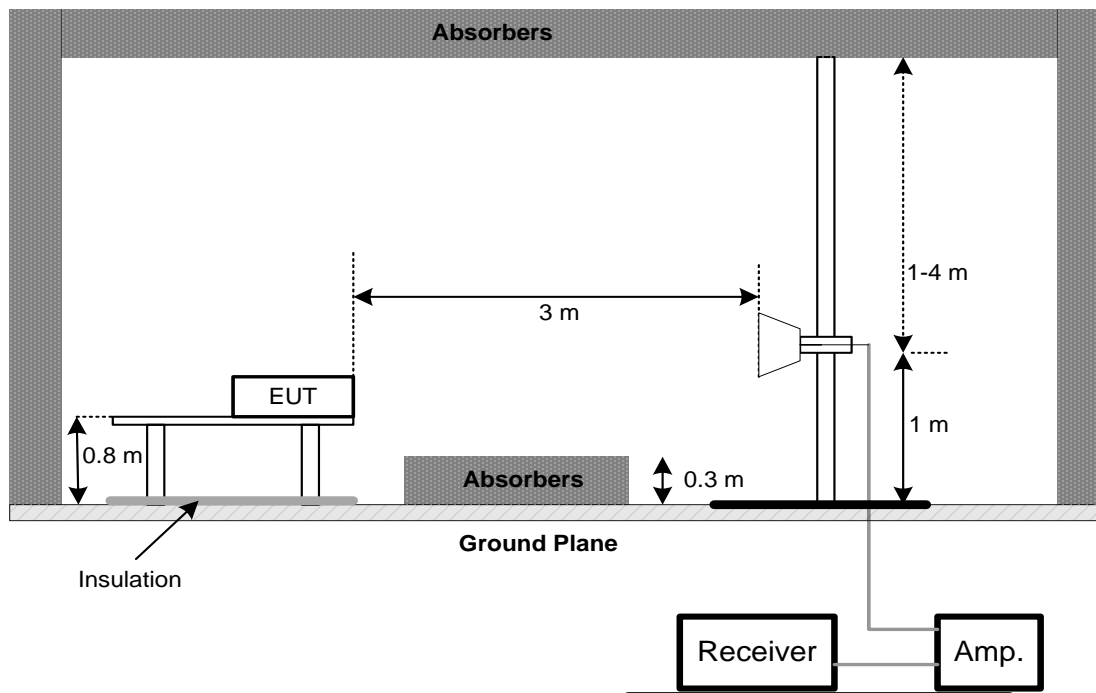

4.1.6 MEASUREMENT DISTANCE

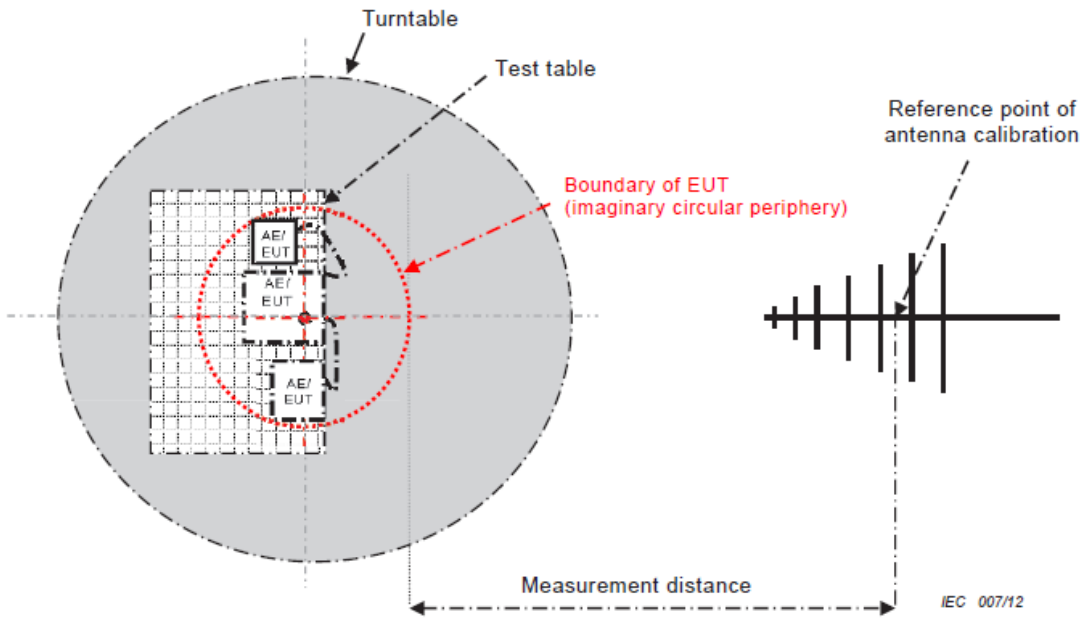

- 34 -

CISPR 32 © IEC:2012

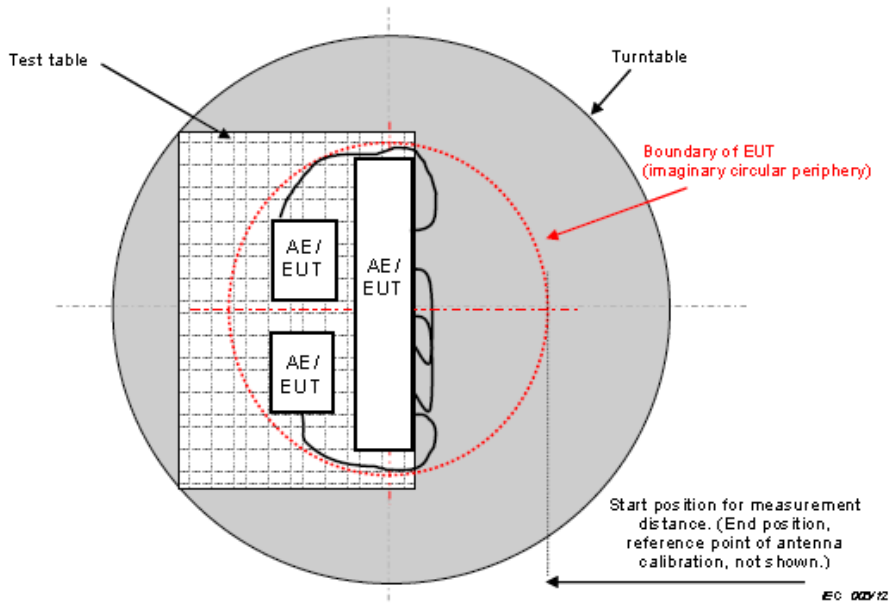
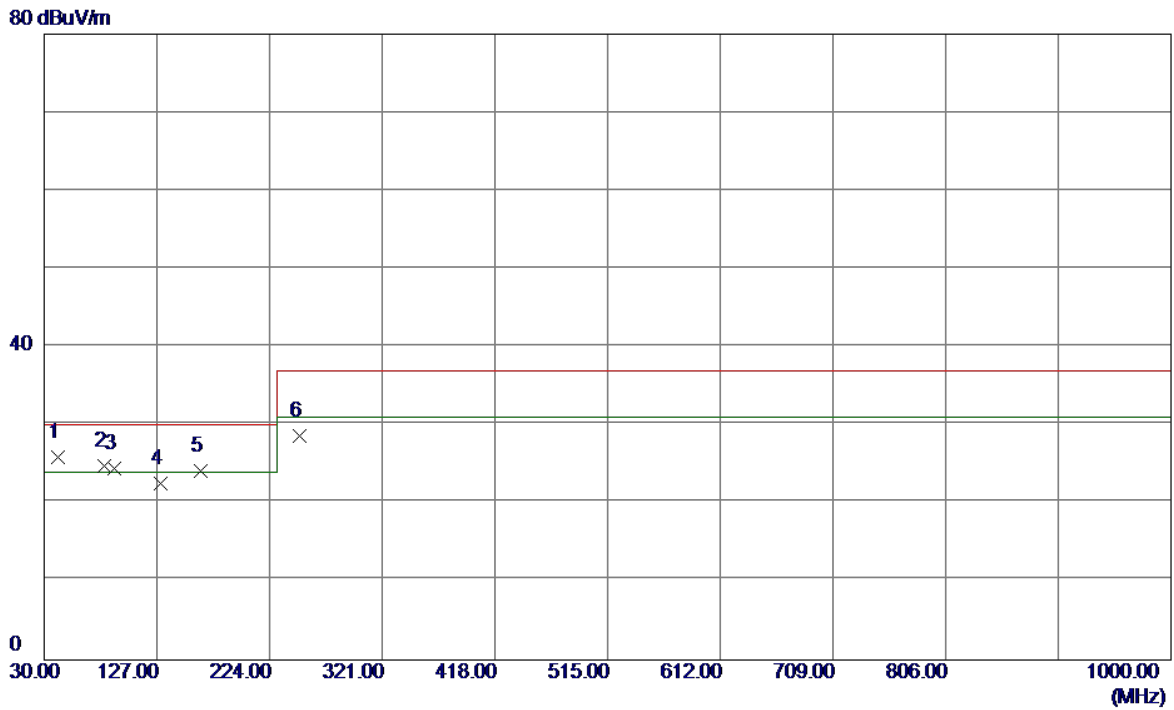

Figure C.2 – Boundary of EUT, Local AE and associated cabling

4.1.7 TEST RESULTS (UP TO 1 GHZ)

EUT	IP Phone	Model Name	F4G
Temperature	25°C	Relative Humidity	60%
Test Voltage	AC 230V/50Hz	Polarization	Vertical
Test Mode	Adapter Supply:Handfree		
Test Engineer	Treyy Chen		



No.	Freq. MHz	Reading Level dBuV/m	Correct Factor dB	Measure ment dBuV/m	Limit dBuV/m	Margin dB	Detector
1 *	41.6400	43.19	-17.20	25.99	30.00	-4.01	QP
2	81.8949	45.14	-20.39	24.75	30.00	-5.25	QP
3	90.6250	46.00	-21.46	24.54	30.00	-5.46	QP
4	130.3950	39.50	-16.91	22.59	30.00	-7.41	QP
5	164.3450	39.61	-15.46	24.15	30.00	-5.85	QP
6	250.1900	44.60	-15.95	28.65	37.00	-8.35	QP

EUT	IP Phone	Model Name	F4G
Temperature	25°C	Relative Humidity	60%
Test Voltage	AC 230V/50Hz	Polarization	Horizontal
Test Mode	Adapter Supply:Handfree		
Test Engineer	Treyy Chen		

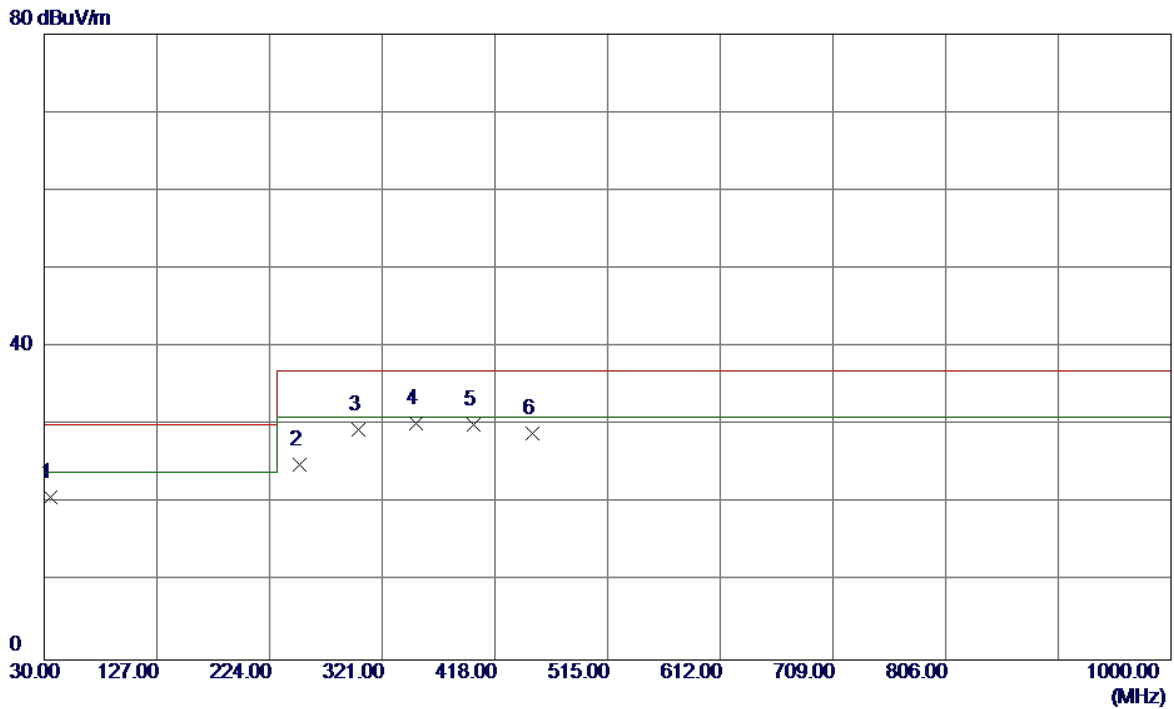

No.	Freq. MHz	Reading Level dBuV/m	Correct Factor dB	Measure ment dBuV/m	Limit dBuV/m	Margin dB	Detector
1	35.8200	38.62	-17.88	20.74	30.00	-9.26	QP
2	250.1900	40.97	-15.95	25.02	37.00	-11.98	QP
3	300.1450	43.37	-14.00	29.37	37.00	-7.63	QP
4 *	350.1000	43.08	-12.89	30.19	37.00	-6.81	QP
5	400.0550	41.56	-11.53	30.03	37.00	-6.97	QP
6	450.0100	38.65	-9.66	28.99	37.00	-8.01	QP

EUT	IP Phone	Model Name	F4G
Temperature	25°C	Relative Humidity	60%
Test Voltage	AC 230V/50Hz	Polarization	Vertical
Test Mode	Adapter Supply:Handset		
Test Engineer	Treyy Chen		

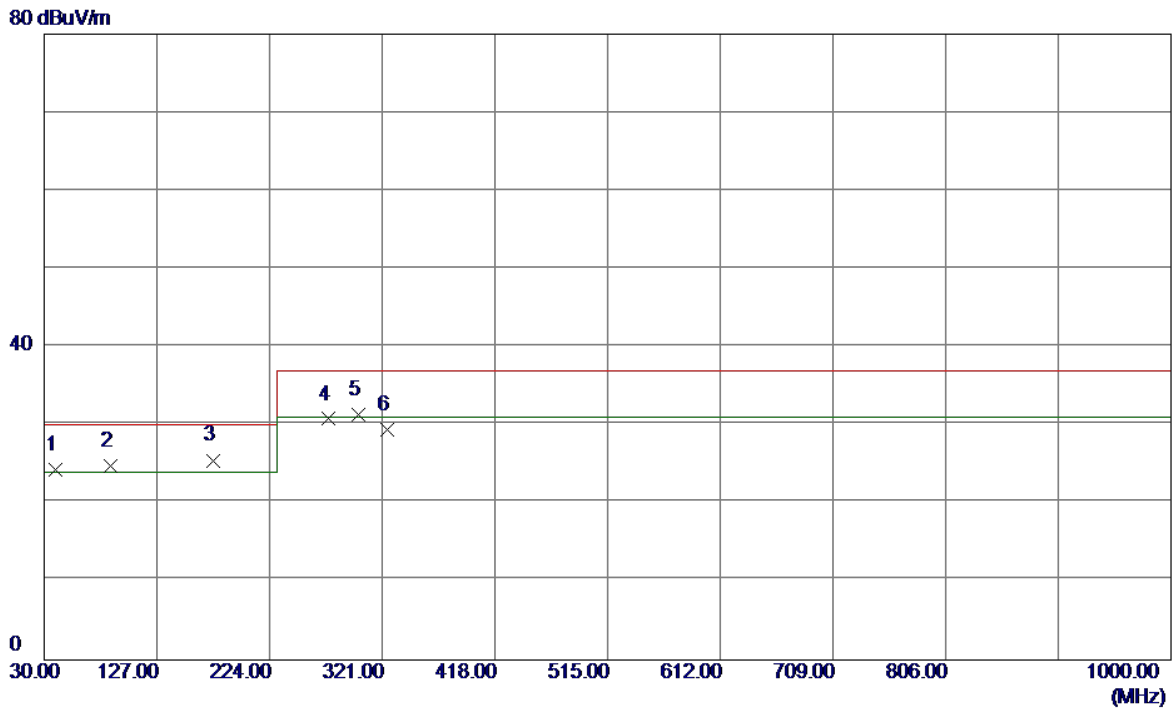

No.	Freq. MHz	Reading Level dBuV/m	Correct Factor dB	Measure ment dBuV/m	Limit dBuV/m	Margin dB	Detector
1	39.2150	41.92	-17.54	24.38	30.00	-5.62	QP
2	86.7450	45.87	-21.07	24.80	30.00	-5.20	QP
3 *	175.0150	41.77	-16.25	25.52	30.00	-4.48	QP
4	274.9250	45.57	-14.77	30.80	37.00	-6.20	QP
5	300.1450	45.35	-14.00	31.35	37.00	-5.65	QP
6	324.8800	42.91	-13.45	29.46	37.00	-7.54	QP

EUT	IP Phone	Model Name	F4G
Temperature	25°C	Relative Humidity	60%
Test Voltage	AC 230V/50Hz	Polarization	Horizontal
Test Mode	Adapter Supply:Handset		
Test Engineer	Treyy Chen		

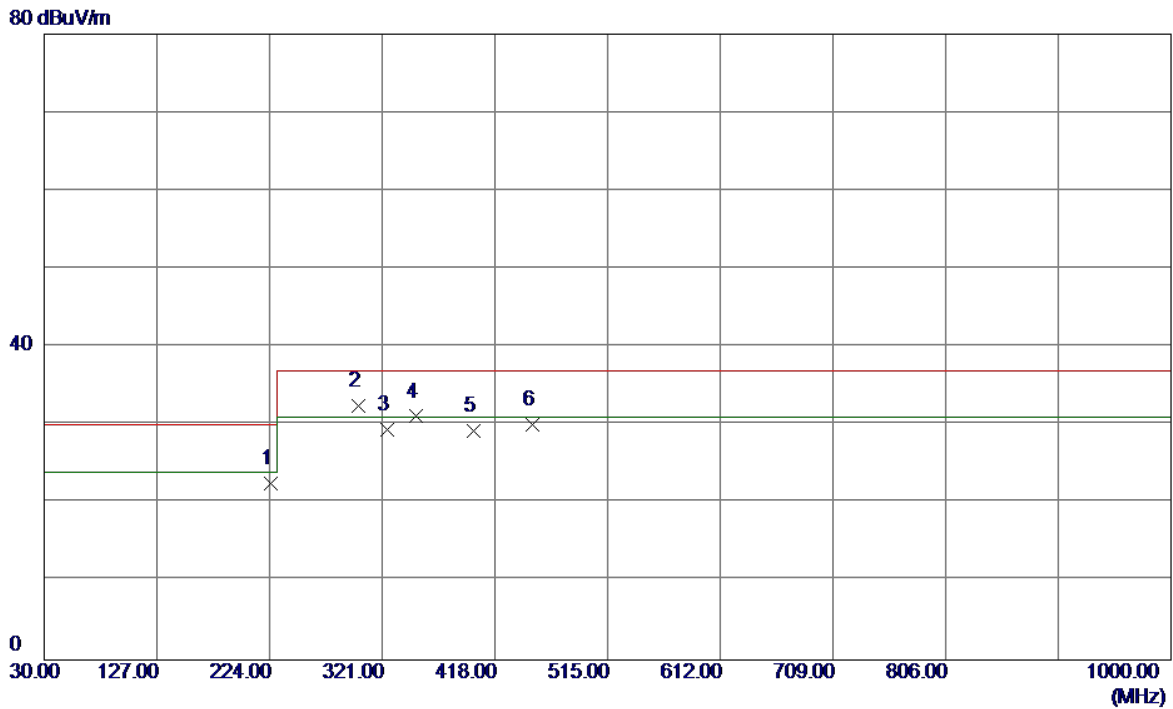

No.	Freq. MHz	Reading Level dBuV/m	Correct Factor dB	Measure ment dBuV/m	Limit dBuV/m	Margin dB	Detector
1	224.9700	40.41	-17.81	22.60	30.00	-7.40	QP
2 *	300.1450	46.43	-14.00	32.43	37.00	-4.57	QP
3	324.8800	42.87	-13.45	29.42	37.00	-7.58	QP
4	350.1000	44.01	-12.89	31.12	37.00	-5.88	QP
5	400.0550	40.84	-11.53	29.31	37.00	-7.69	QP
6	450.0100	39.74	-9.66	30.08	37.00	-6.92	QP

EUT	IP Phone	Model Name	F4G
Temperature	25°C	Relative Humidity	60%
Test Voltage	AC 230V/50Hz	Polarization	Vertical
Test Mode	Adapter Supply:Earphone		
Test Engineer	Treyy Chen		

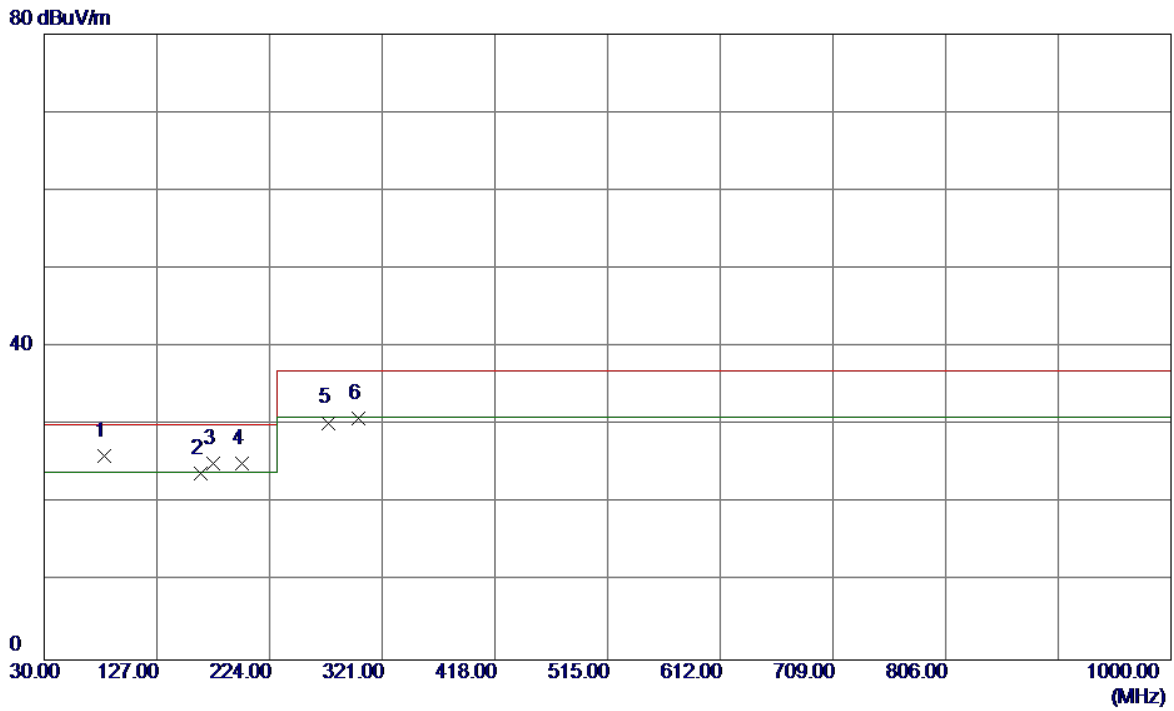

No.	Freq. MHz	Reading Level dBuV/m	Correct Factor dB	Measure ment dBuV/m	Limit dBuV/m	Margin dB	Detector
1 *	81.4100	46.45	-20.32	26.13	30.00	-3.87	QP
2	164.8300	39.35	-15.49	23.86	30.00	-6.14	QP
3	175.9850	41.40	-16.34	25.06	30.00	-4.94	QP
4	200.2350	42.93	-17.83	25.10	30.00	-4.90	QP
5	274.9250	45.09	-14.77	30.32	37.00	-6.68	QP
6	300.1450	44.93	-14.00	30.93	37.00	-6.07	QP

EUT	IP Phone	Model Name	F4G
Temperature	25°C	Relative Humidity	60%
Test Voltage	AC 230V/50Hz	Polarization	Horizontal
Test Mode	Adapter Supply:Earphone		
Test Engineer	Treyy Chen		

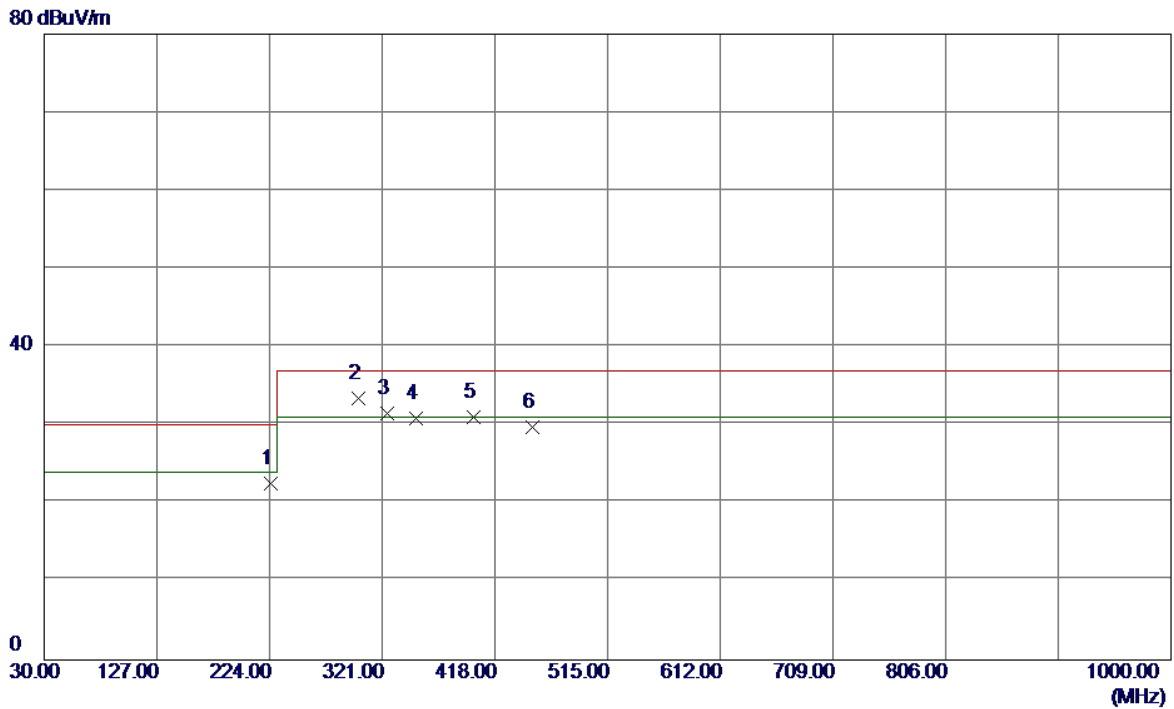

No.	Freq. MHz	Reading Level dBuV/m	Correct Factor dB	Measure ment dBuV/m	Limit dBuV/m	Margin dB	Detector
1	224.9700	40.30	-17.81	22.49	30.00	-7.51	QP
2 *	300.1450	47.49	-14.00	33.49	37.00	-3.51	QP
3	324.8800	44.95	-13.45	31.50	37.00	-5.50	QP
4	350.1000	43.74	-12.89	30.85	37.00	-6.15	QP
5	400.0550	42.54	-11.53	31.01	37.00	-5.99	QP
6	450.0100	39.37	-9.66	29.71	37.00	-7.29	QP

EUT	IP Phone	Model Name	F4G
Temperature	25°C	Relative Humidity	60%
Test Voltage	PoE 48V	Polarization	Vertical
Test Mode	PoE Supply:Handfree		
Test Engineer	Treyy Chen		

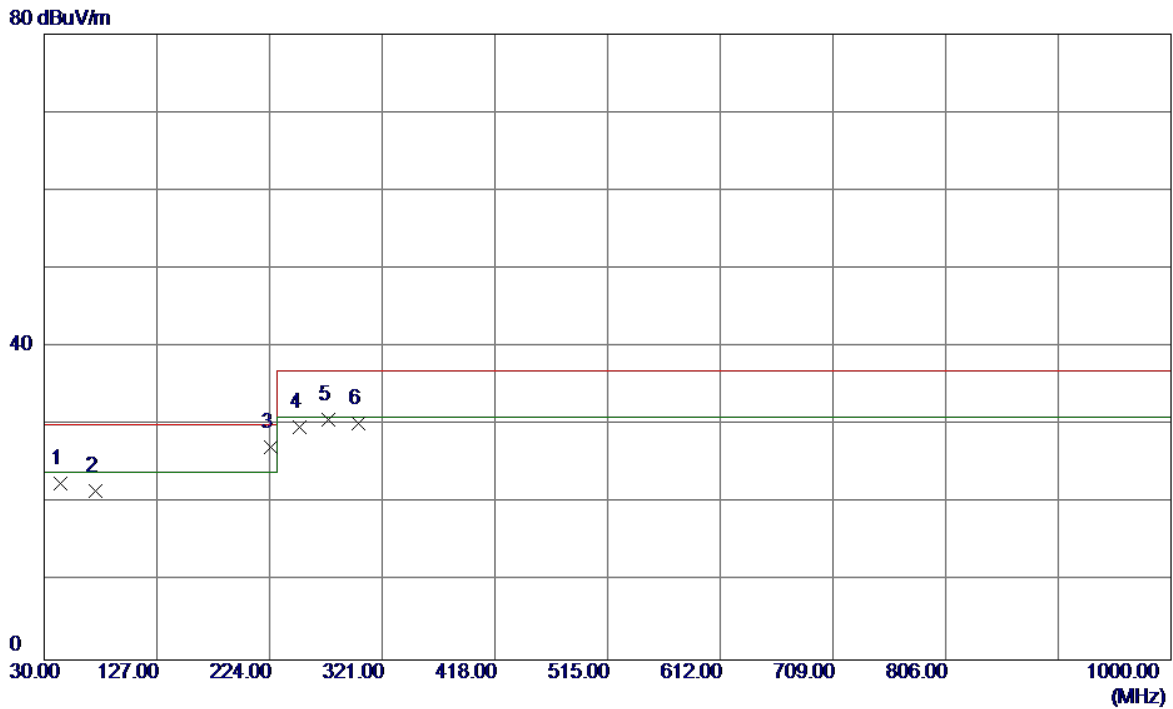

No.	Freq. MHz	Reading Level dBuV/m	Correct Factor dB	Measurement dBuV/m	Limit dBuV/m	Margin dB	Detector
1	43.5800	39.44	-16.90	22.54	30.00	-7.46	QP
2	74.6200	40.63	-19.07	21.56	30.00	-8.44	QP
3 *	224.9700	45.06	-17.81	27.25	30.00	-2.75	QP
4	250.1900	45.69	-15.95	29.74	37.00	-7.26	QP
5	274.9250	45.44	-14.77	30.67	37.00	-6.33	QP
6	300.1450	44.21	-14.00	30.21	37.00	-6.79	QP

EUT	IP Phone	Model Name	F4G
Temperature	25°C	Relative Humidity	60%
Test Voltage	PoE 48V	Polarization	Horizontal
Test Mode	PoE Supply:Handfree		
Test Engineer	Treyy Chen		

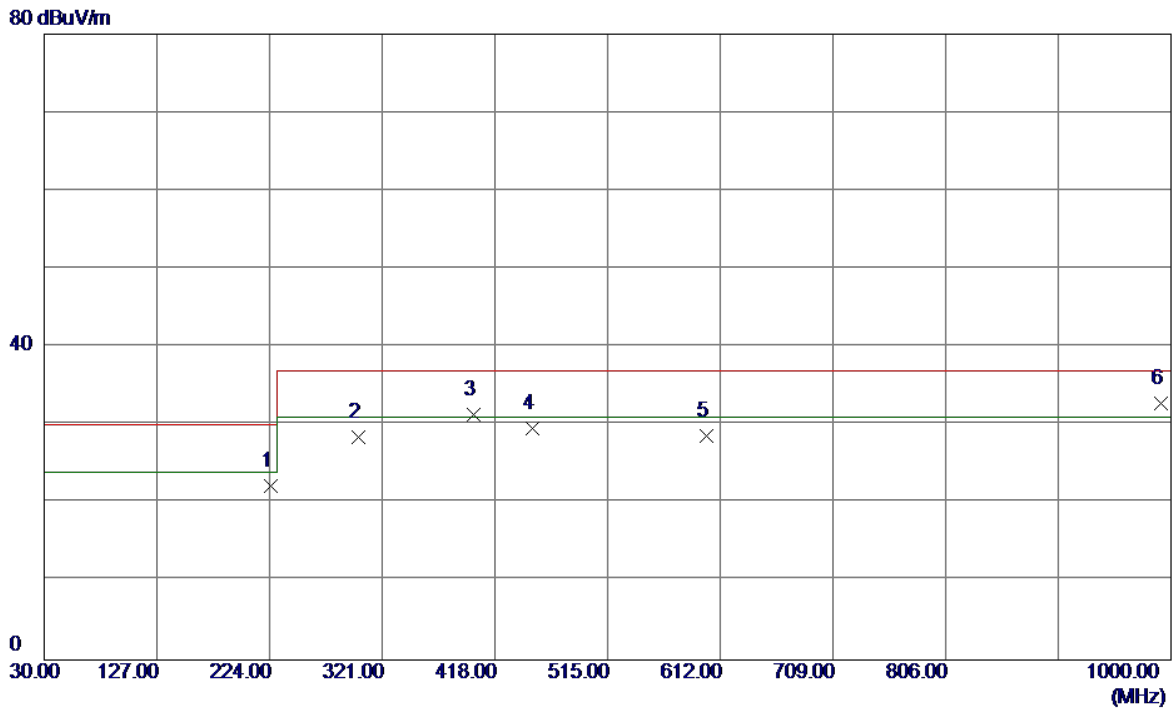

No.	Freq. MHz	Reading Level dBuV/m	Correct Factor dB	Measure ment dBuV/m	Limit dBuV/m	Margin dB	Detector
1	224.9700	39.98	-17.81	22.17	30.00	-7.83	QP
2	300.1450	42.54	-14.00	28.54	37.00	-8.46	QP
3	400.0550	42.92	-11.53	31.39	37.00	-5.61	QP
4	450.0100	39.32	-9.66	29.66	37.00	-7.34	QP
5	599.8750	35.21	-6.58	28.63	37.00	-8.37	QP
6 *	991.2700	33.77	-0.92	32.85	37.00	-4.15	QP

EUT	IP Phone	Model Name	F4G
Temperature	25°C	Relative Humidity	60%
Test Voltage	PoE 48V	Polarization	Vertical
Test Mode	PoE Supply:Handset		
Test Engineer	Treyy Chen		

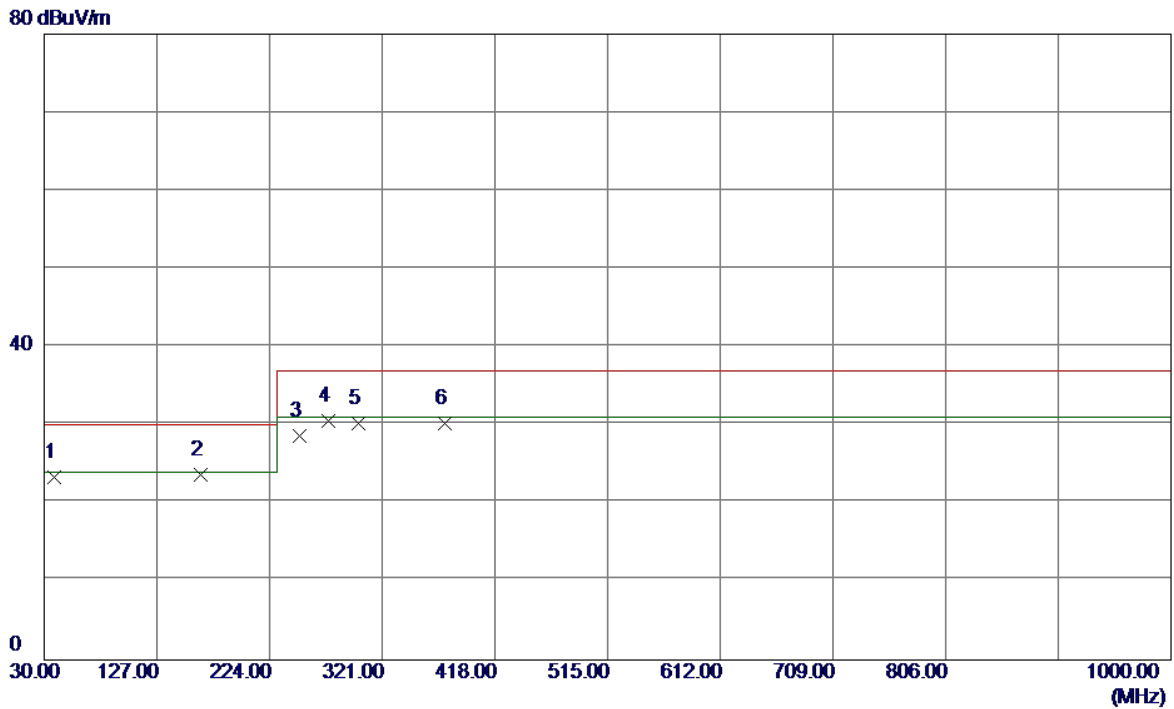

No.	Freq. MHz	Reading Level dBuV/m	Correct Factor dB	Measure ment dBuV/m	Limit dBuV/m	Margin dB	Detector
1	38.2450	41.01	-17.64	23.37	30.00	-6.63	QP
2 *	164.8300	39.18	-15.49	23.69	30.00	-6.31	QP
3	250.1900	44.61	-15.95	28.66	37.00	-8.34	QP
4	274.9250	45.38	-14.77	30.61	37.00	-6.39	QP
5	300.1450	44.18	-14.00	30.18	37.00	-6.82	QP
6	374.8350	42.40	-12.22	30.18	37.00	-6.82	QP

EUT	IP Phone	Model Name	F4G
Temperature	25°C	Relative Humidity	60%
Test Voltage	PoE 48V	Polarization	Horizontal
Test Mode	PoE Supply:Handset		
Test Engineer	Treyy Chen		

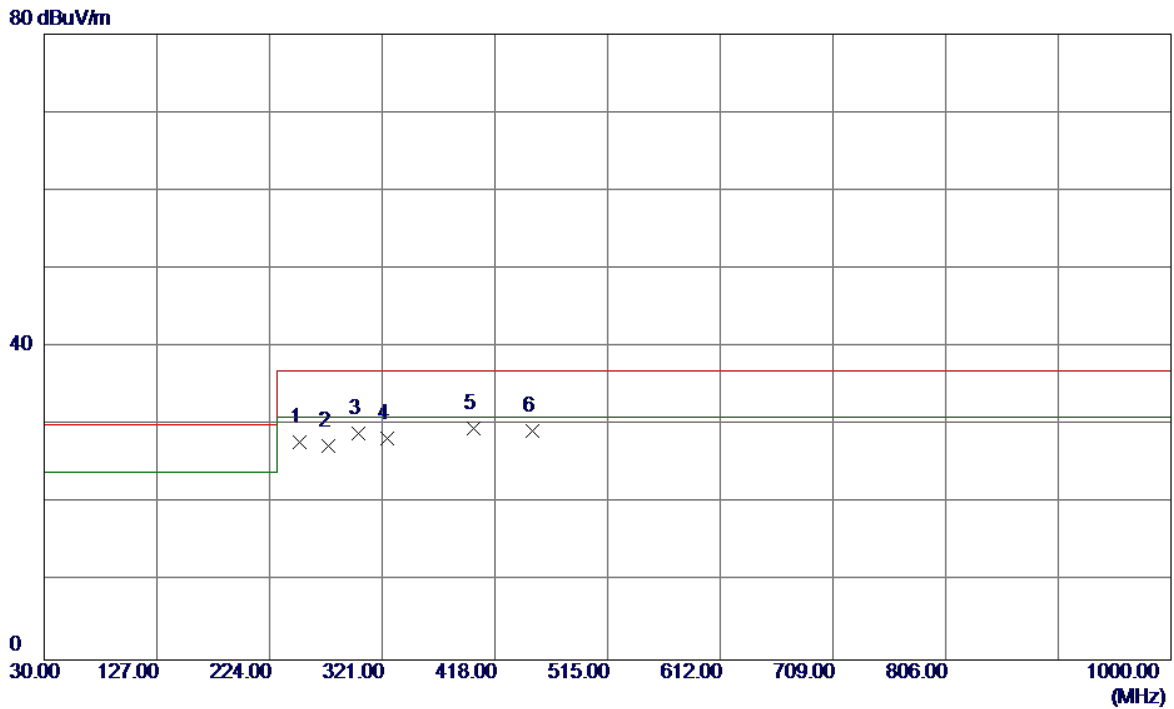

No.	Freq. MHz	Reading Level dBuV/m	Correct Factor dB	Measure ment dBuV/m	Limit dBuV/m	Margin dB	Detector
1	250.1900	43.77	-15.95	27.82	37.00	-9.18	QP
2	274.9250	42.14	-14.77	27.37	37.00	-9.63	QP
3	300.1450	42.97	-14.00	28.97	37.00	-8.03	QP
4	324.8800	41.72	-13.45	28.27	37.00	-8.73	QP
5 *	400.0550	41.07	-11.53	29.54	37.00	-7.46	QP
6	450.0100	38.88	-9.66	29.22	37.00	-7.78	QP

EUT	IP Phone	Model Name	F4G
Temperature	25°C	Relative Humidity	60%
Test Voltage	PoE 48V	Polarization	Vertical
Test Mode	PoE Supply:Earphone		
Test Engineer	Treyy Chen		

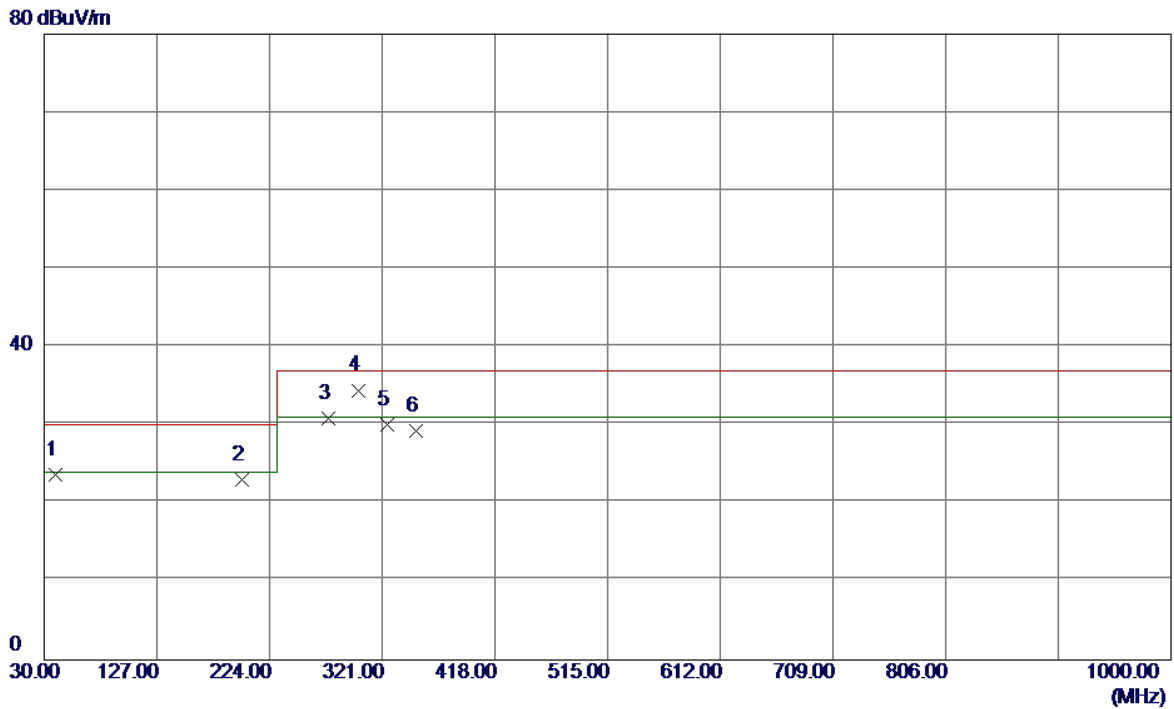

No.	Freq. MHz	Reading Level dBuV/m	Correct Factor dB	Measurement dBuV/m	Limit dBuV/m	Margin dB	Detector
1	39.2150	41.22	-17.54	23.68	30.00	-6.32	QP
2	200.2350	40.94	-17.83	23.11	30.00	-6.89	QP
3	274.9250	45.64	-14.77	30.87	37.00	-6.13	QP
4 *	300.1450	48.48	-14.00	34.48	37.00	-2.52	QP
5	324.8800	43.48	-13.45	30.03	37.00	-6.97	QP
6	350.1000	42.14	-12.89	29.25	37.00	-7.75	QP

EUT	IP Phone	Model Name	F4G
Temperature	25°C	Relative Humidity	60%
Test Voltage	PoE 48V	Polarization	Horizontal
Test Mode	PoE Supply:Earphone		
Test Engineer	Treyy Chen		

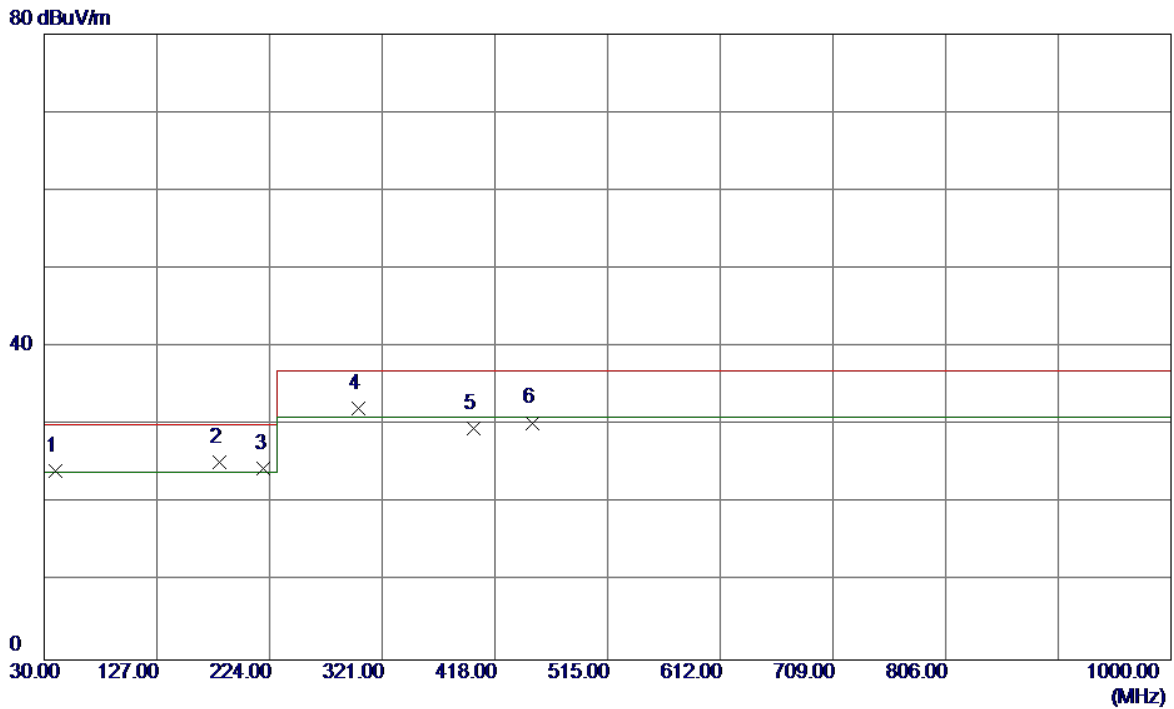

No.	Freq. MHz	Reading Level dBuV/m	Correct Factor dB	Measure ment dBuV/m	Limit dBuV/m	Margin dB	Detector
1	39.2150	41.66	-17.54	24.12	30.00	-5.88	QP
2 *	180.8350	42.08	-16.78	25.30	30.00	-4.70	QP
3	219.1500	42.41	-17.97	24.44	30.00	-5.56	QP
4	300.1450	46.10	-14.00	32.10	37.00	-4.90	QP
5	400.0550	41.14	-11.53	29.61	37.00	-7.39	QP
6	450.0100	39.98	-9.66	30.32	37.00	-6.68	QP

4.1.8 TEST RESULTS (ABOVE 1 GHZ)

EUT	IP Phone	Model Name	F4G
Temperature	25°C	Relative Humidity	60%
Test Voltage	AC 230V/50Hz	Polarization	Vertical
Test Mode	Adapter Supply:Handfree		
Test Engineer	Treyy Chen		

80 dBuV/m

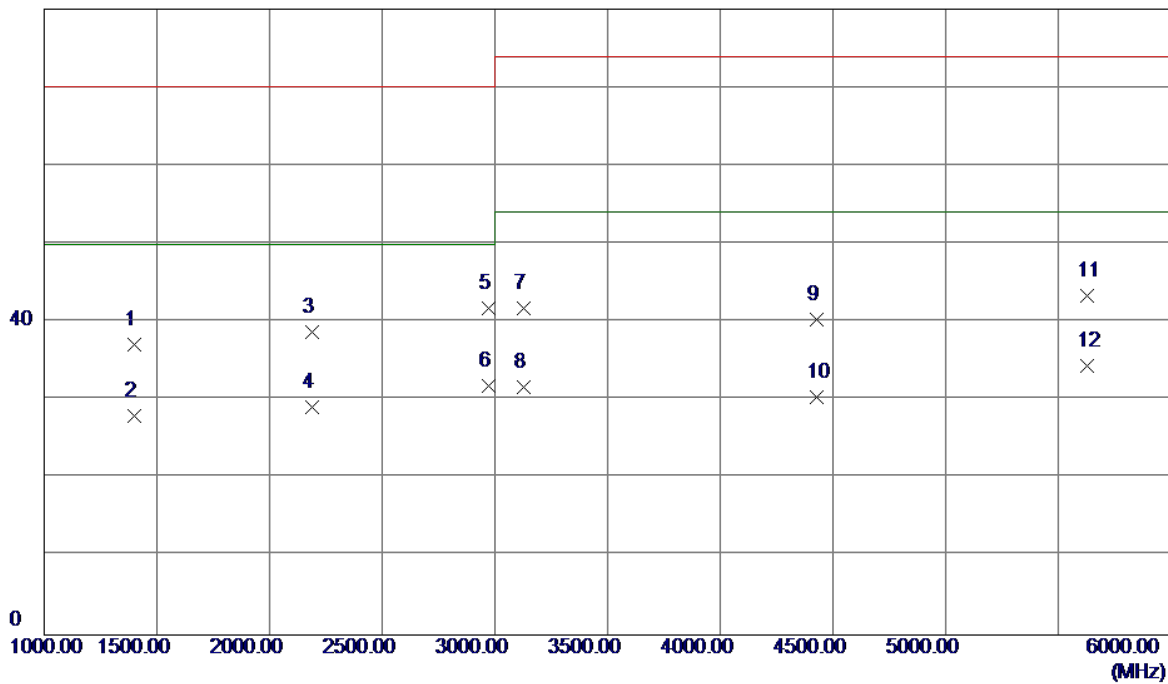

No.	Freq. MHz	Reading Level dBuV/m	Correct Factor dB	Measure ment dBuV/m	Limit dBuV/m	Margin dB	Detector
1	1400.0000	42.45	-5.31	37.14	70.00	-32.86	Peak
2	1400.0000	33.29	-5.31	27.98	50.00	-22.02	AVG
3	2187.5000	40.25	-1.54	38.71	70.00	-31.29	Peak
4	2187.5000	30.71	-1.54	29.17	50.00	-20.83	AVG
5	2970.0000	39.54	2.27	41.81	70.00	-28.19	Peak
6 *	2970.0000	29.64	2.27	31.91	50.00	-18.09	AVG
7	3127.5000	39.47	2.36	41.83	74.00	-32.17	Peak
8	3127.5000	29.25	2.36	31.61	54.00	-22.39	AVG
9	4430.0000	36.63	3.72	40.35	74.00	-33.65	Peak
10	4430.0000	26.74	3.72	30.46	54.00	-23.54	AVG
11	5630.0000	35.28	8.13	43.41	74.00	-30.59	Peak
12	5630.0000	26.34	8.13	34.47	54.00	-19.53	AVG

EUT	IP Phone	Model Name	F4G
Temperature	25°C	Relative Humidity	60%
Test Voltage	AC 230V/50Hz	Polarization	Horizontal
Test Mode	Adapter Supply:Handfree		
Test Engineer	Treyy Chen		

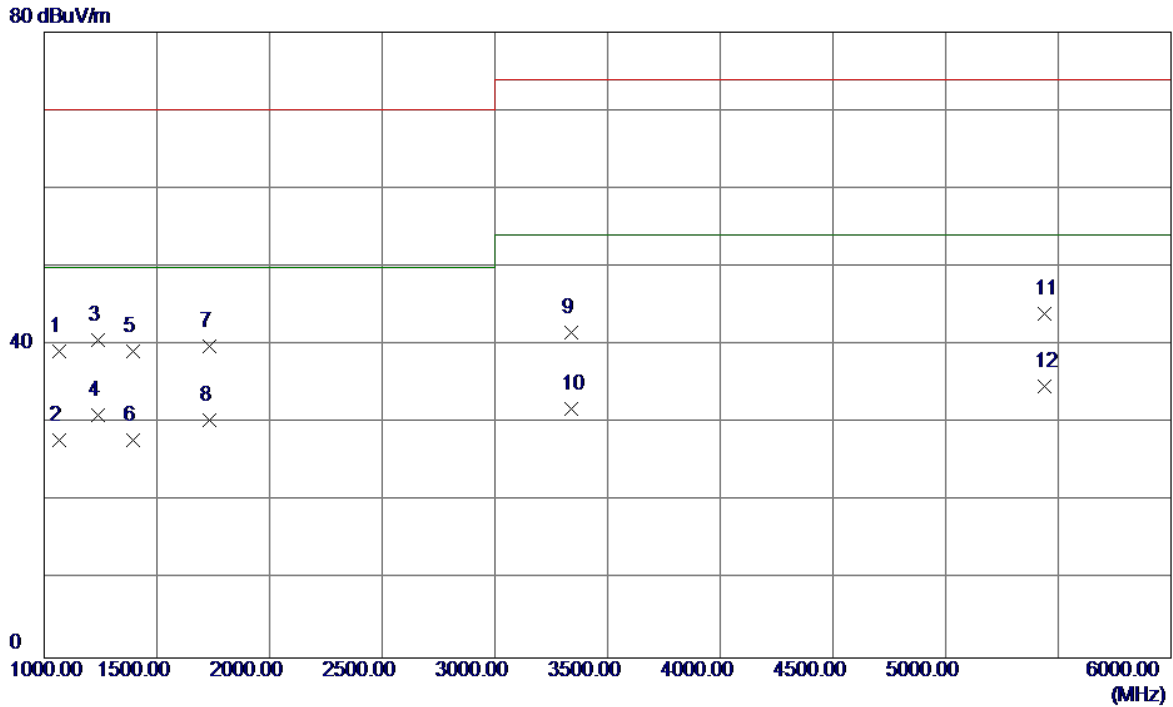

No.	Freq. MHz	Reading Level dBuV/m	Correct Factor dB	Measurement dBuV/m	Limit dBuV/m	Margin dB	Detector
1	1067.5000	45.69	-6.49	39.20	70.00	-30.80	Peak
2	1067.5000	34.29	-6.49	27.80	50.00	-22.20	AVG
3	1237.5000	46.58	-5.88	40.70	70.00	-29.30	Peak
4 *	1237.5000	36.94	-5.88	31.06	50.00	-18.94	AVG
5	1392.5000	44.55	-5.33	39.22	70.00	-30.78	Peak
6	1392.5000	33.17	-5.33	27.84	50.00	-22.16	AVG
7	1732.5000	43.76	-3.84	39.92	70.00	-30.08	Peak
8	1732.5000	34.27	-3.84	30.43	50.00	-19.57	AVG
9	3340.0000	39.35	2.30	41.65	74.00	-32.35	Peak
10	3340.0000	29.48	2.30	31.78	54.00	-22.22	AVG
11	5437.5000	36.16	7.80	43.96	74.00	-30.04	Peak
12	5437.5000	26.94	7.80	34.74	54.00	-19.26	AVG

EUT	IP Phone	Model Name	F4G
Temperature	25°C	Relative Humidity	60%
Test Voltage	AC 230V/50Hz	Polarization	Vertical
Test Mode	Adapter Supply:Handset		
Test Engineer	Treyy Chen		

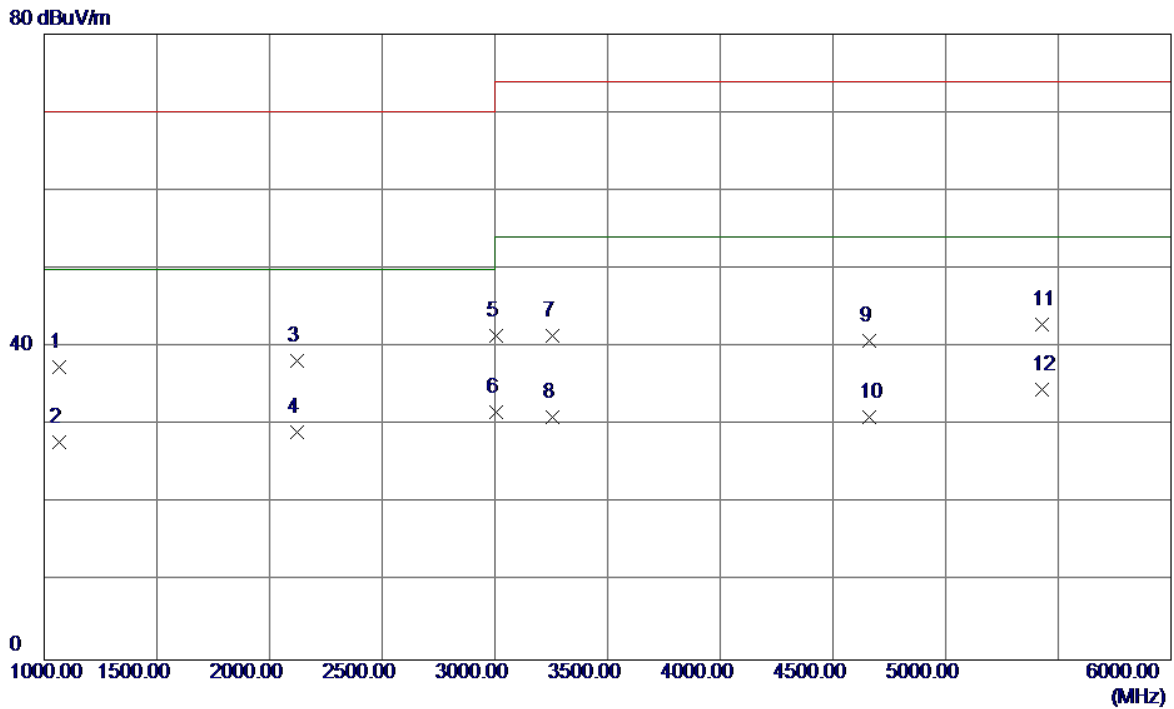

No.	Freq. MHz	Reading Level dBuV/m	Correct Factor dB	Measure ment dBuV/m	Limit dBuV/m	Margin dB	Detector
1	1067.5000	43.86	-6.49	37.37	70.00	-32.63	Peak
2	1067.5000	34.26	-6.49	27.77	50.00	-22.23	AVG
3	2122.5000	40.12	-1.90	38.22	70.00	-31.78	Peak
4	2122.5000	30.95	-1.90	29.05	50.00	-20.95	AVG
5	3007.5000	39.10	2.40	41.50	74.00	-32.50	Peak
6	3007.5000	29.34	2.40	31.74	54.00	-22.26	AVG
7	3257.5000	39.18	2.33	41.51	74.00	-32.49	Peak
8	3257.5000	28.67	2.33	31.00	54.00	-23.00	AVG
9	4662.5000	36.18	4.67	40.85	74.00	-33.15	Peak
10	4662.5000	26.43	4.67	31.10	54.00	-22.90	AVG
11	5427.5000	35.14	7.76	42.90	74.00	-31.10	Peak
12 *	5427.5000	26.83	7.76	34.59	54.00	-19.41	AVG

EUT	IP Phone	Model Name	F4G
Temperature	25°C	Relative Humidity	60%
Test Voltage	AC 230V/50Hz	Polarization	Horizontal
Test Mode	Adapter Supply:Handset		
Test Engineer	Treyy Chen		

80 dBuV/m

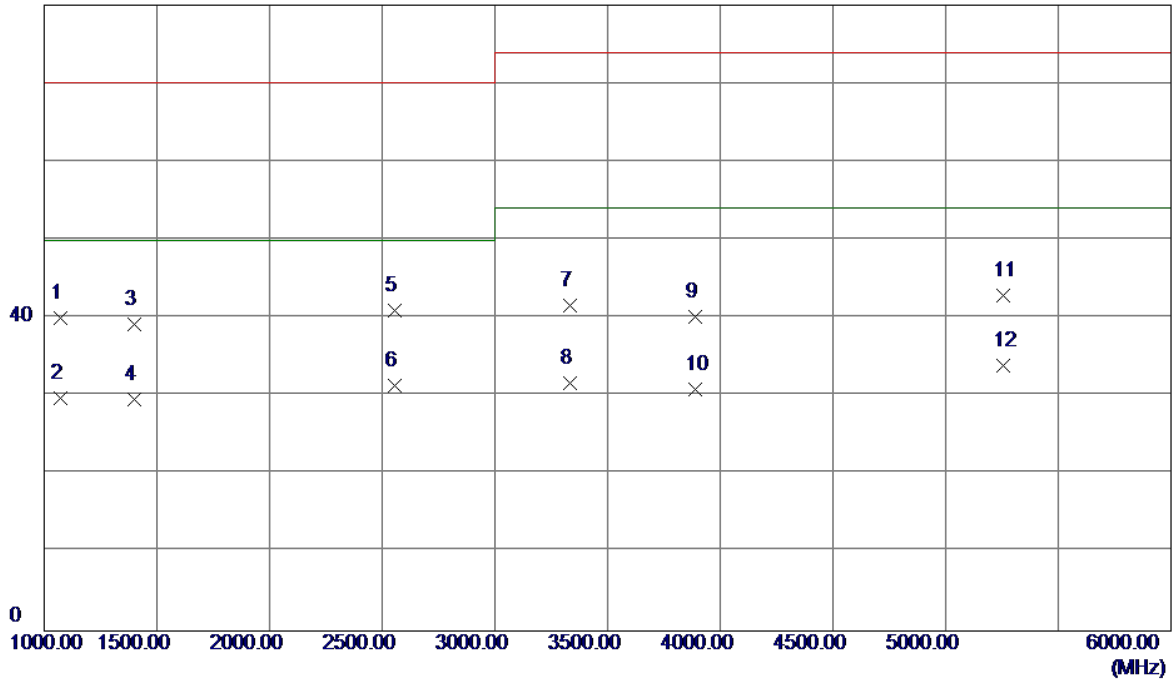

No.	Freq. MHz	Reading Level dBuV/m	Correct Factor dB	Measure ment dBuV/m	Limit dBuV/m	Margin dB	Detector
1	1070.0000	46.48	-6.48	40.00	70.00	-30.00	Peak
2	1070.0000	36.25	-6.48	29.77	50.00	-20.23	AVG
3	1397.5000	44.49	-5.31	39.18	70.00	-30.82	Peak
4	1397.5000	34.84	-5.31	29.53	50.00	-20.47	AVG
5	2557.5000	40.57	0.43	41.00	70.00	-29.00	Peak
6 *	2557.5000	30.96	0.43	31.39	50.00	-18.61	AVG
7	3335.0000	39.26	2.30	41.56	74.00	-32.44	Peak
8	3335.0000	29.35	2.30	31.65	54.00	-22.35	AVG
9	3890.0000	37.51	2.62	40.13	74.00	-33.87	Peak
10	3890.0000	28.30	2.62	30.92	54.00	-23.08	AVG
11	5255.0000	35.74	7.18	42.92	74.00	-31.08	Peak
12	5255.0000	26.75	7.18	33.93	54.00	-20.07	AVG

EUT	IP Phone	Model Name	F4G
Temperature	25°C	Relative Humidity	60%
Test Voltage	AC 230V/50Hz	Polarization	Vertical
Test Mode	Adapter Supply:Earphone		
Test Engineer	Treyy Chen		

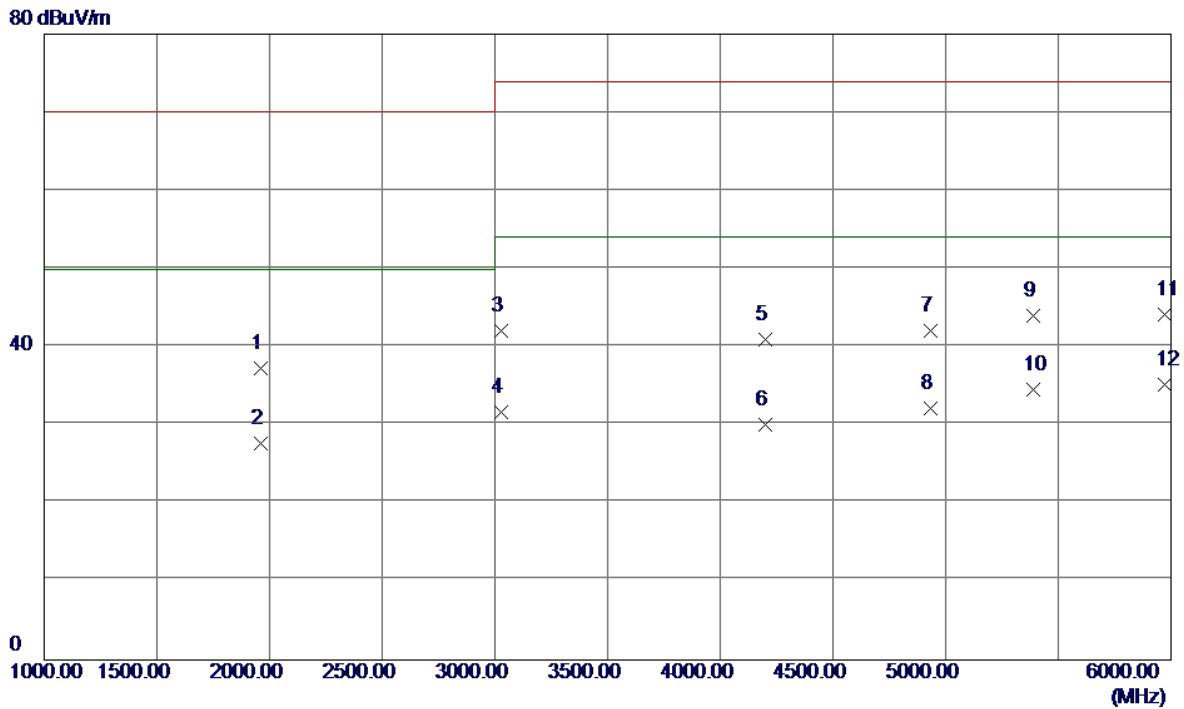

No.	Freq. MHz	Reading Level dBuV/m	Correct Factor dB	Measure ment dBuV/m	Limit dBuV/m	Margin dB	Detector
1	1960.0000	40.11	-2.76	37.35	70.00	-32.65	Peak
2	1960.0000	30.41	-2.76	27.65	50.00	-22.35	AVG
3	3030.0000	39.76	2.39	42.15	74.00	-31.85	Peak
4	3030.0000	29.35	2.39	31.74	54.00	-22.26	AVG
5	4197.5000	37.85	3.18	41.03	74.00	-32.97	Peak
6	4197.5000	26.84	3.18	30.02	54.00	-23.98	AVG
7	4932.5000	36.10	5.98	42.08	74.00	-31.92	Peak
8	4932.5000	26.21	5.98	32.19	54.00	-21.81	AVG
9	5387.5000	36.34	7.63	43.97	74.00	-30.03	Peak
10	5387.5000	26.94	7.63	34.57	54.00	-19.43	AVG
11	5975.0000	35.70	8.44	44.14	74.00	-29.86	Peak
12 *	5975.0000	26.74	8.44	35.18	54.00	-18.82	AVG

EUT	IP Phone	Model Name	F4G
Temperature	25°C	Relative Humidity	60%
Test Voltage	AC 230V/50Hz	Polarization	Horizontal
Test Mode	Adapter Supply:Earphone		
Test Engineer	Treyy Chen		

80 dBuV/m

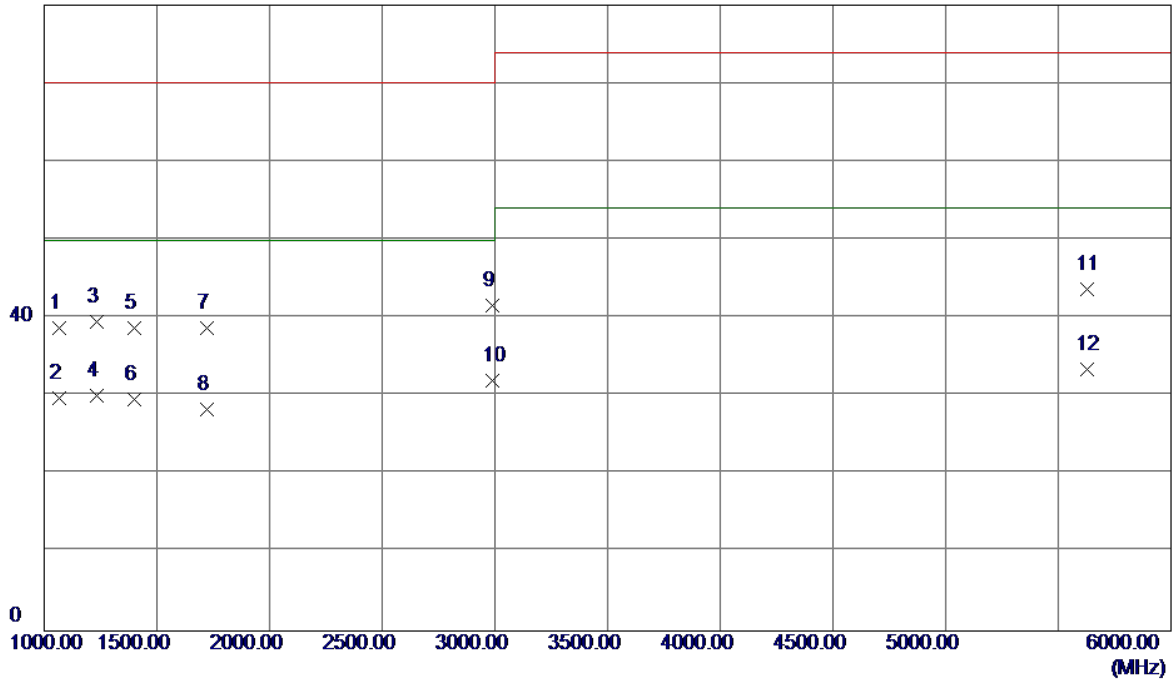

No.	Freq. MHz	Reading Level dBuV/m	Correct Factor dB	Measure ment dBuV/m	Limit dBuV/m	Margin dB	Detector
1	1065.0000	45.21	-6.50	38.71	70.00	-31.29	Peak
2	1065.0000	36.25	-6.50	29.75	50.00	-20.25	AVG
3	1235.0000	45.46	-5.89	39.57	70.00	-30.43	Peak
4	1235.0000	35.94	-5.89	30.05	50.00	-19.95	AVG
5	1397.5000	44.10	-5.31	38.79	70.00	-31.21	Peak
6	1397.5000	34.97	-5.31	29.66	50.00	-20.34	AVG
7	1722.5000	42.66	-3.89	38.77	70.00	-31.23	Peak
8	1722.5000	32.16	-3.89	28.27	50.00	-21.73	AVG
9	2990.0000	39.18	2.36	41.54	70.00	-28.46	Peak
10 *	2990.0000	29.57	2.36	31.93	50.00	-18.07	AVG
11	5625.0000	35.56	8.12	43.68	74.00	-30.32	Peak
12	5625.0000	25.35	8.12	33.47	54.00	-20.53	AVG

EUT	IP Phone	Model Name	F4G
Temperature	25°C	Relative Humidity	60%
Test Voltage	PoE 48V	Polarization	Vertical
Test Mode	PoE Supply:Handfree		
Test Engineer	Treyy Chen		

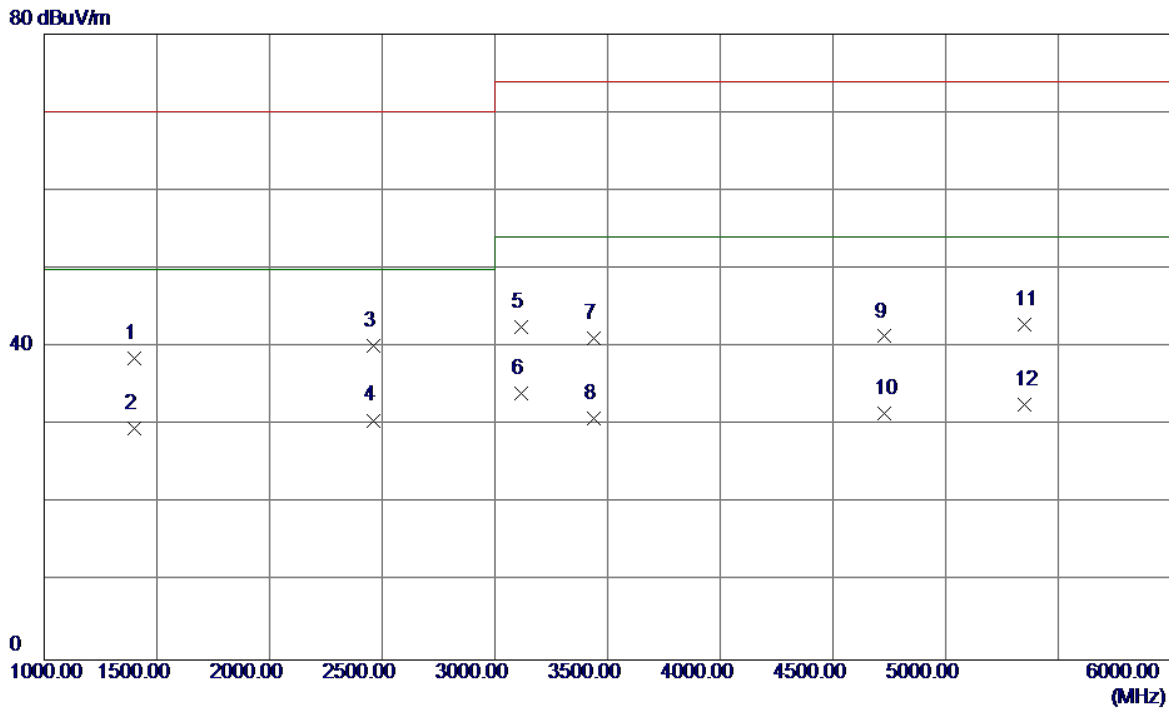

No.	Freq. MHz	Reading Level dBuV/m	Correct Factor dB	Measurement dBuV/m	Limit dBuV/m	Margin dB	Detector
1	1397.5000	43.93	-5.31	38.62	70.00	-31.38	Peak
2	1397.5000	34.95	-5.31	29.64	50.00	-20.36	AVG
3	2462.5000	40.18	-0.04	40.14	70.00	-29.86	Peak
4 *	2462.5000	30.68	-0.04	30.64	50.00	-19.36	AVG
5	3117.5000	40.23	2.37	42.60	74.00	-31.40	Peak
6	3117.5000	31.67	2.37	34.04	54.00	-19.96	AVG
7	3440.0000	38.83	2.27	41.10	74.00	-32.90	Peak
8	3440.0000	28.65	2.27	30.92	54.00	-23.08	AVG
9	4730.0000	36.36	5.00	41.36	74.00	-32.64	Peak
10	4730.0000	26.53	5.00	31.53	54.00	-22.47	AVG
11	5350.0000	35.41	7.50	42.91	74.00	-31.09	Peak
12	5350.0000	25.14	7.50	32.64	54.00	-21.36	AVG

EUT	IP Phone	Model Name	F4G
Temperature	25°C	Relative Humidity	60%
Test Voltage	PoE 48V	Polarization	Horizontal
Test Mode	PoE Supply:Handfree		
Test Engineer	Treyy Chen		

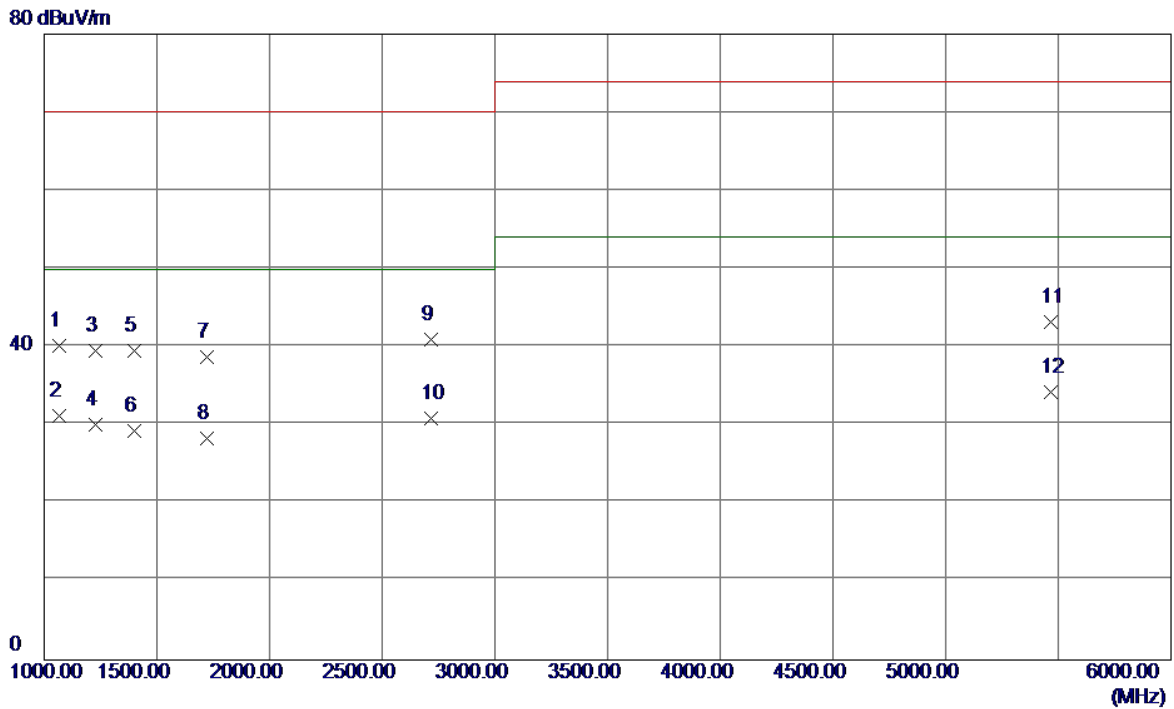

No.	Freq. MHz	Reading Level dBuV/m	Correct Factor dB	Measure ment dBuV/m	Limit dBuV/m	Margin dB	Detector
1	1067.5000	46.63	-6.49	40.14	70.00	-29.86	Peak
2 *	1067.5000	37.66	-6.49	31.17	50.00	-18.83	AVG
3	1230.0000	45.38	-5.91	39.47	70.00	-30.53	Peak
4	1230.0000	35.97	-5.91	30.06	50.00	-19.94	AVG
5	1397.5000	44.76	-5.31	39.45	70.00	-30.55	Peak
6	1397.5000	34.64	-5.31	29.33	50.00	-20.67	AVG
7	1720.0000	42.69	-3.90	38.79	70.00	-31.21	Peak
8	1720.0000	32.16	-3.90	28.26	50.00	-21.74	AVG
9	2715.0000	39.79	1.13	40.92	70.00	-29.08	Peak
10	2715.0000	29.80	1.13	30.93	50.00	-19.07	AVG
11	5467.5000	35.37	7.90	43.27	74.00	-30.73	Peak
12	5467.5000	26.34	7.90	34.24	54.00	-19.76	AVG

EUT	IP Phone	Model Name	F4G
Temperature	25°C	Relative Humidity	60%
Test Voltage	PoE 48V	Polarization	Vertical
Test Mode	PoE Supply:Handset		
Test Engineer	Treyy Chen		

80 dBuV/m

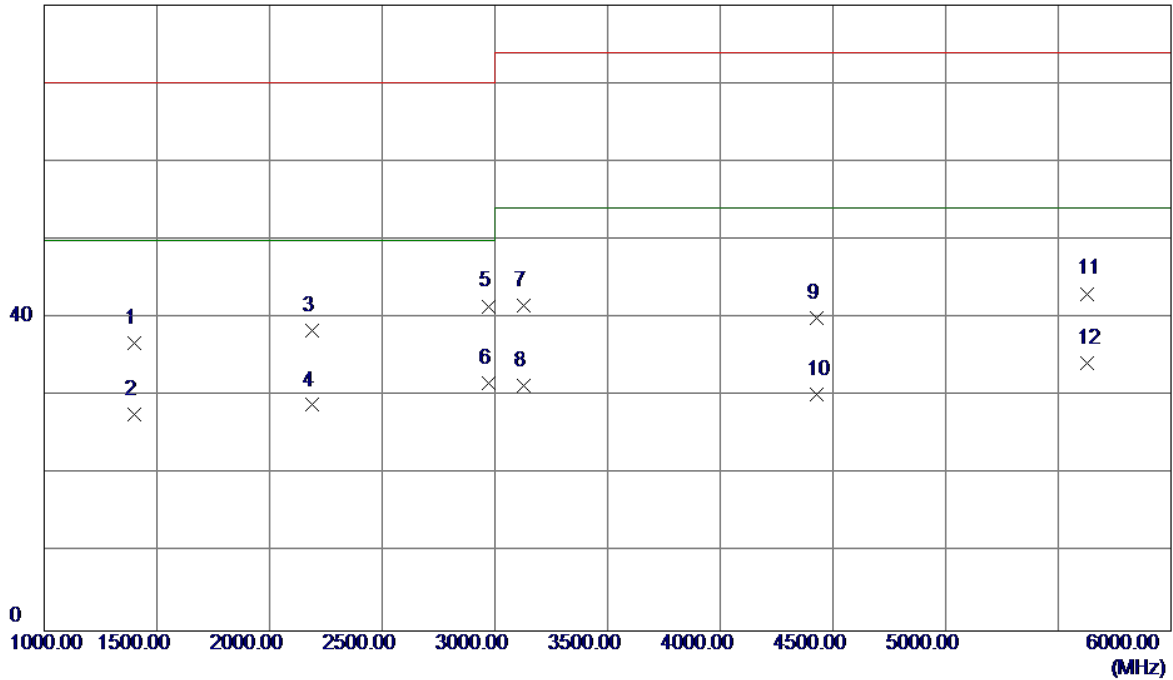

No.	Freq. MHz	Reading Level dBuV/m	Correct Factor dB	Measure ment dBuV/m	Limit dBuV/m	Margin dB	Detector
1	1400.0000	42.16	-5.31	36.85	70.00	-33.15	Peak
2	1400.0000	33.00	-5.31	27.69	50.00	-22.31	AVG
3	2187.5000	39.96	-1.54	38.42	70.00	-31.58	Peak
4	2187.5000	30.42	-1.54	28.88	50.00	-21.12	AVG
5	2970.0000	39.25	2.27	41.52	70.00	-28.48	Peak
6 *	2970.0000	29.35	2.27	31.62	50.00	-18.38	AVG
7	3127.5000	39.18	2.36	41.54	74.00	-32.46	Peak
8	3127.5000	28.96	2.36	31.32	54.00	-22.68	AVG
9	4430.0000	36.34	3.72	40.06	74.00	-33.94	Peak
10	4430.0000	26.45	3.72	30.17	54.00	-23.83	AVG
11	5630.0000	34.99	8.13	43.12	74.00	-30.88	Peak
12	5630.0000	26.05	8.13	34.18	54.00	-19.82	AVG

EUT	IP Phone	Model Name	F4G
Temperature	25°C	Relative Humidity	60%
Test Voltage	PoE 48V	Polarization	Horizontal
Test Mode	PoE Supply:Handset		
Test Engineer	Treyy Chen		

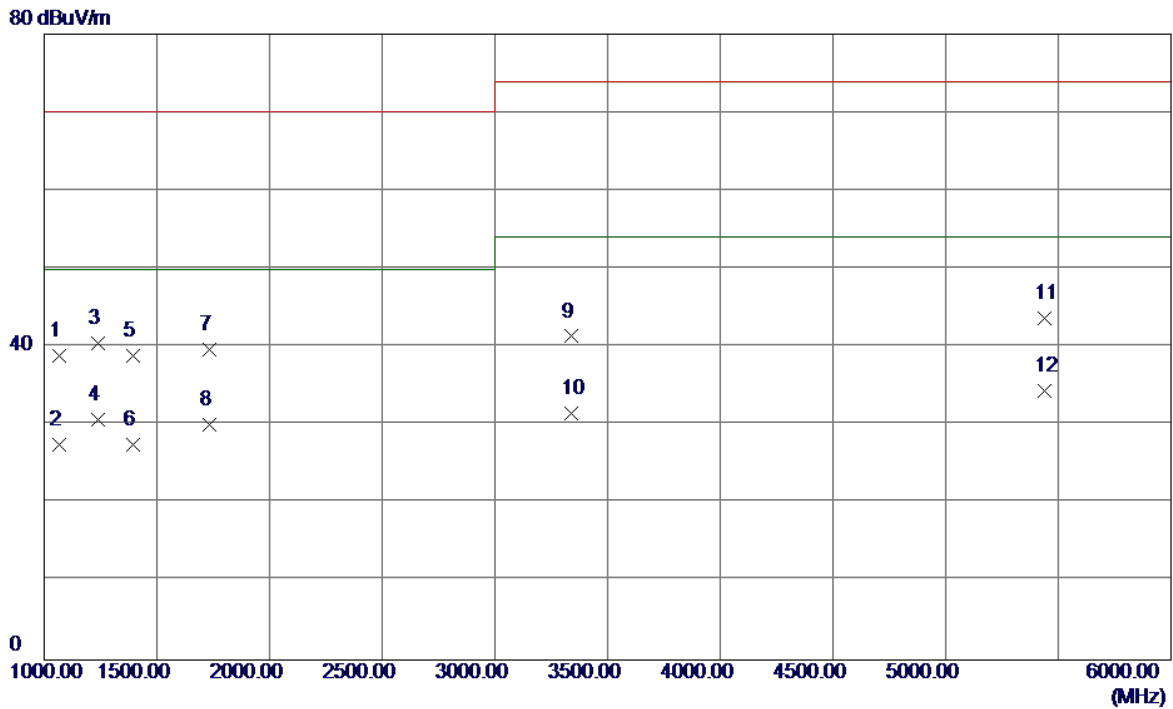

No.	Freq. MHz	Reading Level dBuV/m	Correct Factor dB	Measure ment dBuV/m	Limit dBuV/m	Margin dB	Detector
1	1067.5000	45.40	-6.49	38.91	70.00	-31.09	Peak
2	1067.5000	34.00	-6.49	27.51	50.00	-22.49	AVG
3	1237.5000	46.29	-5.88	40.41	70.00	-29.59	Peak
4 *	1237.5000	36.65	-5.88	30.77	50.00	-19.23	AVG
5	1392.5000	44.26	-5.33	38.93	70.00	-31.07	Peak
6	1392.5000	32.88	-5.33	27.55	50.00	-22.45	AVG
7	1732.5000	43.47	-3.84	39.63	70.00	-30.37	Peak
8	1732.5000	33.98	-3.84	30.14	50.00	-19.86	AVG
9	3340.0000	39.06	2.30	41.36	74.00	-32.64	Peak
10	3340.0000	29.19	2.30	31.49	54.00	-22.51	AVG
11	5437.5000	35.87	7.80	43.67	74.00	-30.33	Peak
12	5437.5000	26.65	7.80	34.45	54.00	-19.55	AVG

EUT	IP Phone	Model Name	F4G
Temperature	25°C	Relative Humidity	60%
Test Voltage	PoE 48V	Polarization	Vertical
Test Mode	PoE Supply:Earphone		
Test Engineer	Treyy Chen		

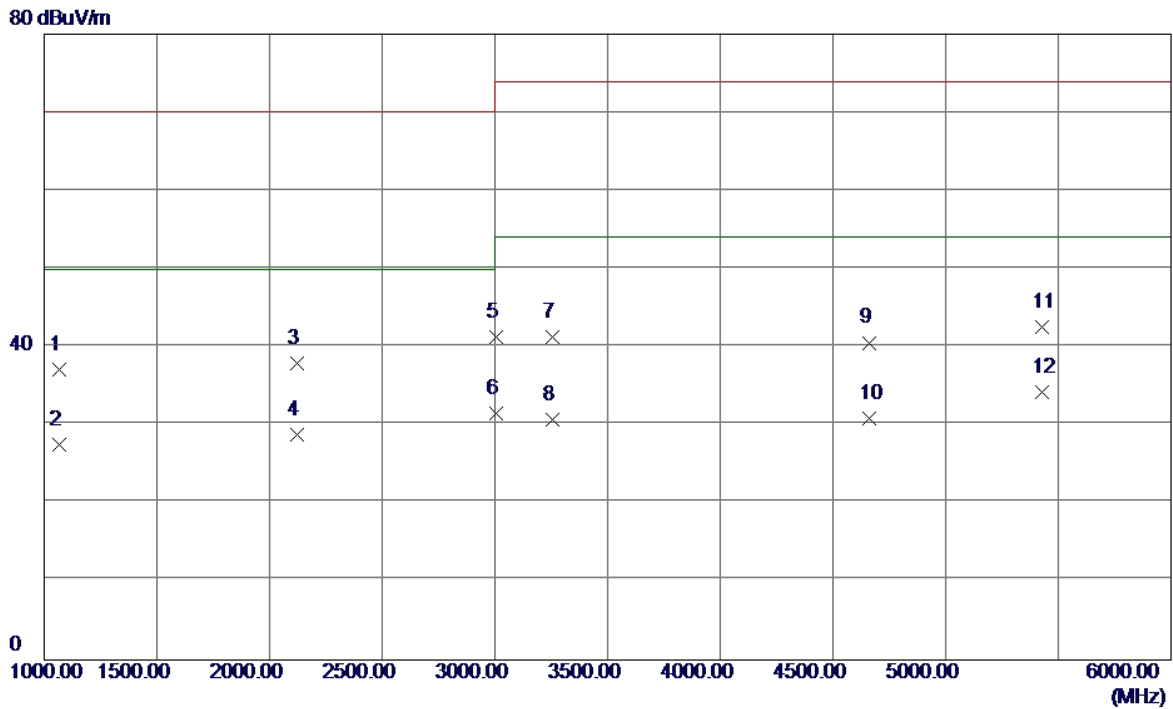

No.	Freq. MHz	Reading Level dBuV/m	Correct Factor dB	Measurement dBuV/m	Limit dBuV/m	Margin dB	Detector
1	1067.5000	43.57	-6.49	37.08	70.00	-32.92	Peak
2	1067.5000	33.97	-6.49	27.48	50.00	-22.52	AVG
3	2122.5000	39.83	-1.90	37.93	70.00	-32.07	Peak
4	2122.5000	30.66	-1.90	28.76	50.00	-21.24	AVG
5	3007.5000	38.81	2.40	41.21	74.00	-32.79	Peak
6	3007.5000	29.05	2.40	31.45	54.00	-22.55	AVG
7	3257.5000	38.89	2.33	41.22	74.00	-32.78	Peak
8	3257.5000	28.38	2.33	30.71	54.00	-23.29	AVG
9	4662.5000	35.89	4.67	40.56	74.00	-33.44	Peak
10	4662.5000	26.14	4.67	30.81	54.00	-23.19	AVG
11	5427.5000	34.85	7.76	42.61	74.00	-31.39	Peak
12 *	5427.5000	26.54	7.76	34.30	54.00	-19.70	AVG

EUT	IP Phone	Model Name	F4G
Temperature	25°C	Relative Humidity	60%
Test Voltage	PoE 48V	Polarization	Horizontal
Test Mode	PoE Supply:Earphone		
Test Engineer	Treyy Chen		

80 dBuV/m

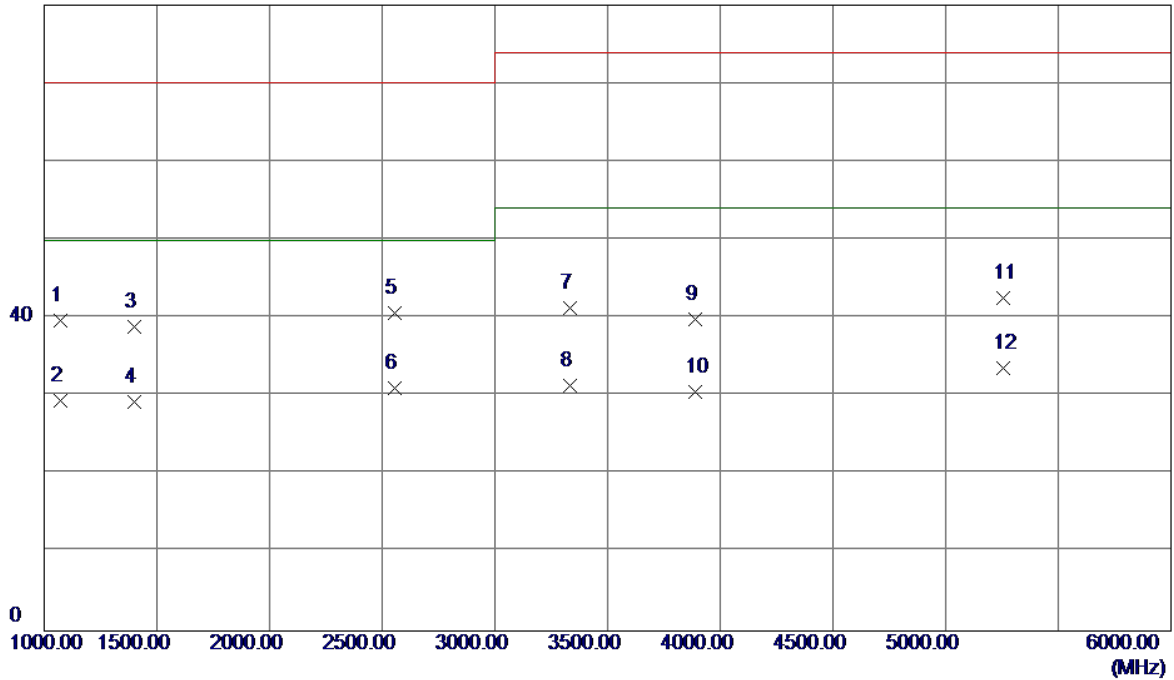

No.	Freq. MHz	Reading Level dBuV/m	Correct Factor dB	Measure ment dBuV/m	Limit dBuV/m	Margin dB	Detector
1	1070.0000	46.19	-6.48	39.71	70.00	-30.29	Peak
2	1070.0000	35.96	-6.48	29.48	50.00	-20.52	AVG
3	1397.5000	44.20	-5.31	38.89	70.00	-31.11	Peak
4	1397.5000	34.55	-5.31	29.24	50.00	-20.76	AVG
5	2557.5000	40.28	0.43	40.71	70.00	-29.29	Peak
6 *	2557.5000	30.67	0.43	31.10	50.00	-18.90	AVG
7	3335.0000	38.97	2.30	41.27	74.00	-32.73	Peak
8	3335.0000	29.06	2.30	31.36	54.00	-22.64	AVG
9	3890.0000	37.22	2.62	39.84	74.00	-34.16	Peak
10	3890.0000	28.01	2.62	30.63	54.00	-23.37	AVG
11	5255.0000	35.45	7.18	42.63	74.00	-31.37	Peak
12	5255.0000	26.46	7.18	33.64	54.00	-20.36	AVG

4.2 CONDUCTED EMISSION MEASUREMENT AT AC MAINS POWER PORTS

4.2.1 LIMITS

Requirements for conducted emissions from AC mains power ports of Class A equipment

Table clause	Frequency Range MHz	Coupling Device	Detector Type / bandwidth	Class A Limits (dB(μV))
A8.1	0.15 - 0.5	AMN	Quasi Peak / 9 kHz	79
	0.5 - 30			73
A8.2	0.15 - 0.5	AMN	Average / 9 kHz	66
	0.5 - 30			60

Requirements for conducted emissions from AC mains power ports of Class B equipment

Table clause	Frequency Range MHz	Coupling Device	Detector Type / bandwidth	Class B Limits (dB(μV))
A9.1	0.15 - 0.5	AMN	Quasi Peak / 9 kHz	66-56
	0.5 - 5			56
	5 - 30			60
A9.2	0.15 - 0.5	AMN	Average / 9 kHz	56-46
	0.5 - 5			46
	5 - 30			50

NOTE:

- (1) The test result calculated as following:
 Measurement Value = Reading Level + Correct Factor
 Correct Factor = Insertion Loss + Cable Loss + Attenuator Factor(if use)
 Margin Level = Measurement Value – Limit Value

4.2.2 MEASUREMENT INSTRUMENTS LIST

Item	Kind of Equipment	Manufacturer	Type No.	Serial No.	Calibrated until
1	50Ω Terminator	SHX	TF2-3G-A	8122901	Mar. 27, 2017
2	TWO-LINE V-NETWORK	R&S	ENV216	100526	Mar. 27, 2017
3	EMI Test Receiver	R&S	ESR3	101862	Sep. 04, 2017
4	Artificial-Mains Network	SCHWARZBECK	NSLK 8127	8127685	Sep. 04, 2017
5	Cable	N/A	RG400 12m	N/A	Mar. 10, 2017
6	Measurement Software	Farad	EZ-EMC Ver.NB-03A 1-01	N/A	N/A

Remark: "N/A" denotes no model name, no serial no. or no calibration specified.
 All calibration period of equipment list is one year.

4.2.3 TEST PROCEDURE

- The EUT was placed 0.8 meters from the horizontal ground plane with EUT being connected to the power mains through a line impedance stabilization network (LISN). All other support equipments powered from additional LISN(s). The LISN provide 50 Ohm/ 50uH of coupling impedance for the measuring instrument.
- Interconnecting cables that hang closer than 40 cm to the ground plane shall be folded back and forth in the center forming a bundle 30 to 40 cm long.
- I/O cables that are not connected to a peripheral shall be bundled in the center. The end of the cable may be terminated, if required, using the correct terminating impedance. The overall length shall not exceed 1 m.
- LISN at least 80 cm from nearest part of EUT chassis.
- For the actual test configuration, please refer to the related Item –EUT Test Photos.

4.2.4 DEVIATION FROM TEST STANDARD

No deviation

4.2.5 TEST SETUP

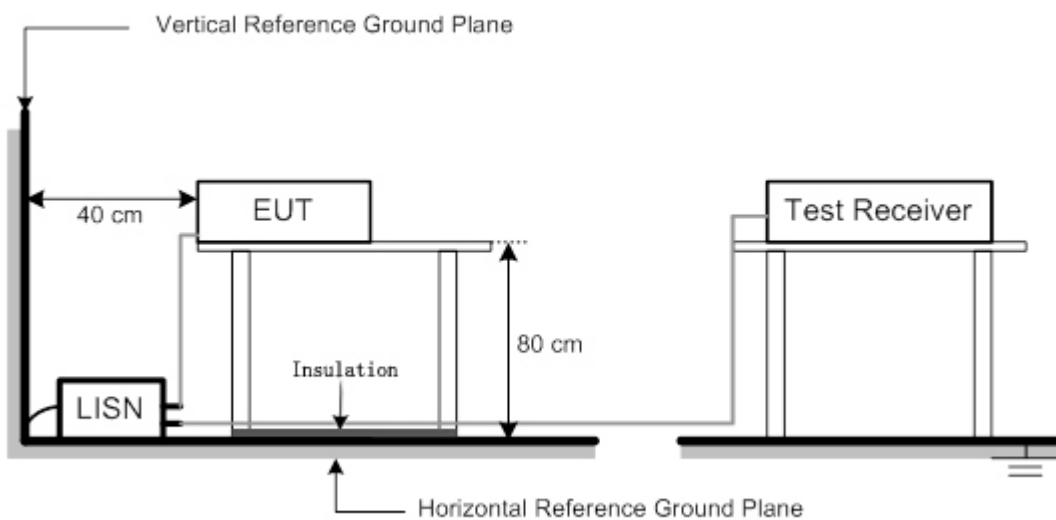

4.2.6 TEST RESULTS

EUT	IP Phone	Model Name	F4G
Temperature	25°C	Relative Humidity	53%
Test Voltage	AC 230V/50Hz	Phase	Line
Test Mode	Adapter Supply:Handfree		
Test Engineer	Treyy Chen		

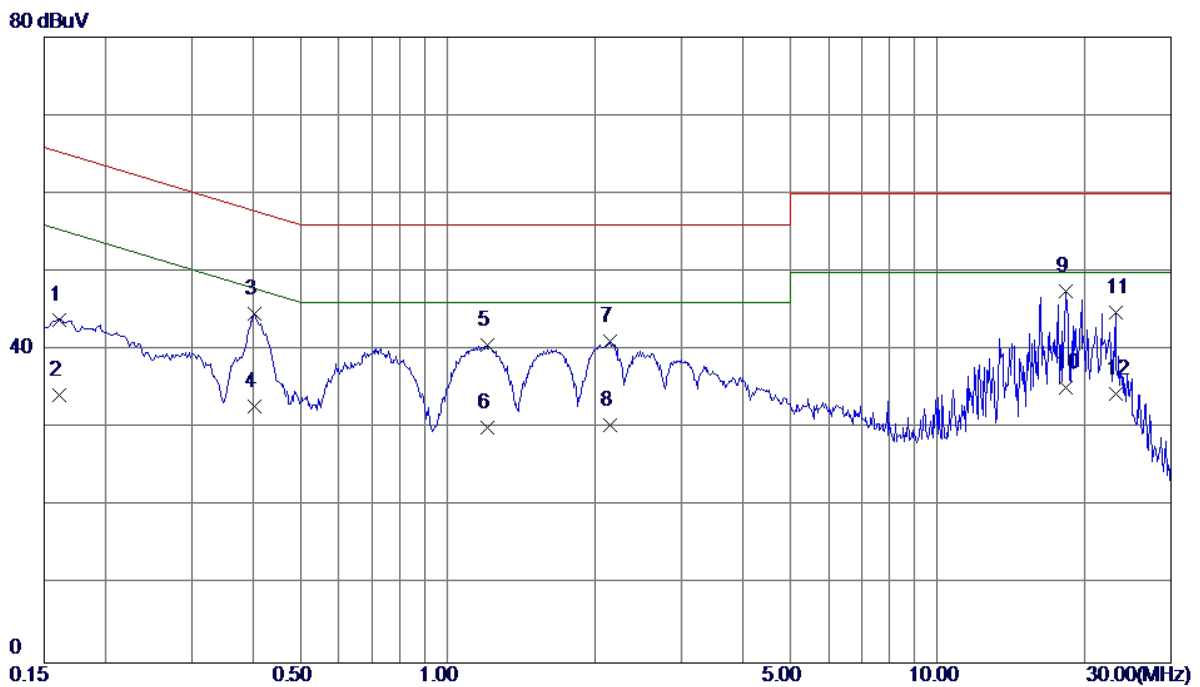

No.	Freq. MHz	Reading Level dBuV	Correct Factor dB	Measure ment dBuV	Limit dBuV	Margin dB	Detector
1	0.1613	34.27	9.65	43.92	65.40	-21.48	QP
2	0.1613	24.60	9.65	34.25	55.40	-21.15	AVG
3	0.4042	34.71	9.87	44.58	57.77	-13.19	QP
4	0.4042	22.90	9.87	32.77	47.77	-15.00	AVG
5	1.2030	30.38	10.23	40.61	56.00	-15.39	QP
6	1.2030	19.80	10.23	30.03	46.00	-15.97	AVG
7	2.1413	31.11	10.08	41.19	56.00	-14.81	QP
8	2.1413	20.30	10.08	30.38	46.00	-15.62	AVG
9 *	18.2445	36.77	10.68	47.45	60.00	-12.55	QP
10	18.2445	24.50	10.68	35.18	50.00	-14.82	AVG
11	23.1293	33.99	10.74	44.73	60.00	-15.27	QP
12	23.1293	23.70	10.74	34.44	50.00	-15.56	AVG

EUT	IP Phone	Model Name	F4G
Temperature	25°C	Relative Humidity	53%
Test Voltage	AC 230V/50Hz	Phase	Neutral
Test Mode	Adapter Supply:Handfree		
Test Engineer	Treyy Chen		

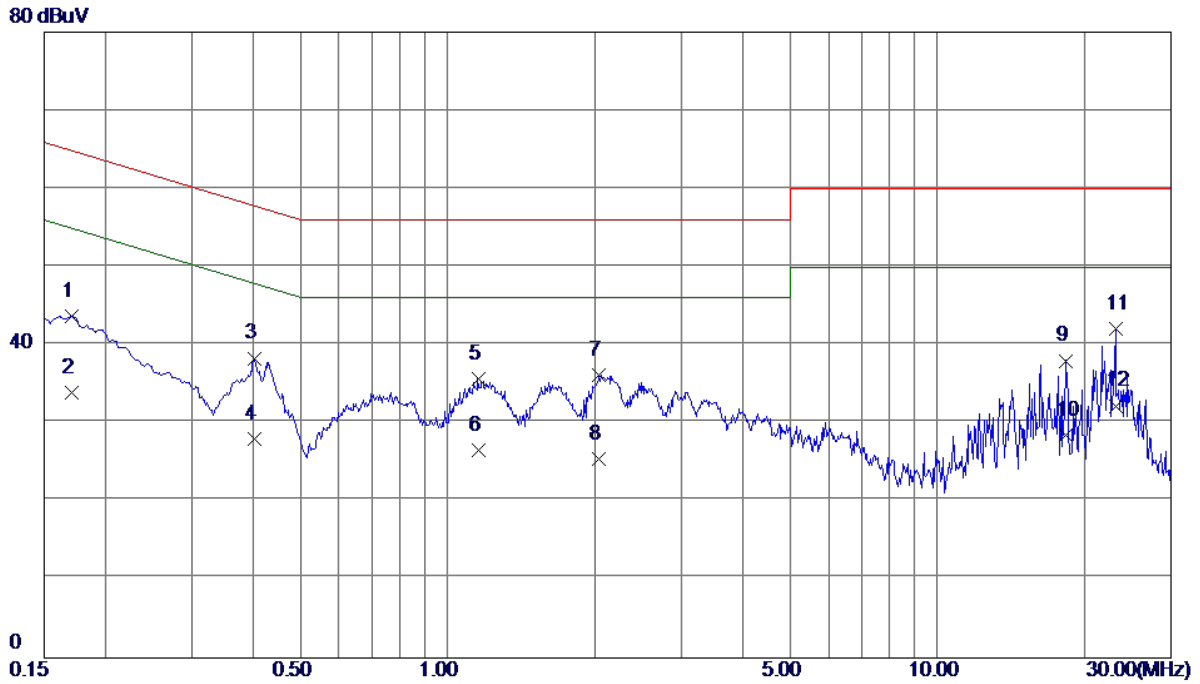

No.	Freq. MHz	Reading Level dBuV	Correct Factor dB	Measure ment dBuV	Limit dBuV	Margin dB	Detector
1	0.1703	34.18	9.55	43.73	64.95	-21.22	QP
2	0.1703	24.30	9.55	33.85	54.95	-21.10	AVG
3	0.4042	28.55	9.77	38.32	57.77	-19.45	QP
4	0.4042	18.20	9.77	27.97	47.77	-19.80	AVG
5	1.1535	25.77	9.93	35.70	56.00	-20.30	QP
6	1.1535	16.70	9.93	26.63	46.00	-19.37	AVG
7	2.0355	26.10	10.07	36.17	56.00	-19.83	QP
8	2.0355	15.40	10.07	25.47	46.00	-20.53	AVG
9	18.2445	27.36	10.64	38.00	60.00	-22.00	QP
10	18.2445	17.80	10.64	28.44	50.00	-21.56	AVG
11	23.1293	31.40	10.74	42.14	60.00	-17.86	QP
12 *	23.1293	21.50	10.74	32.24	50.00	-17.76	AVG

EUT	IP Phone	Model Name	F4G
Temperature	25°C	Relative Humidity	53%
Test Voltage	AC 230V/50Hz	Phase	Line
Test Mode	Adapter Supply:Handset		
Test Engineer	Treyy Chen		

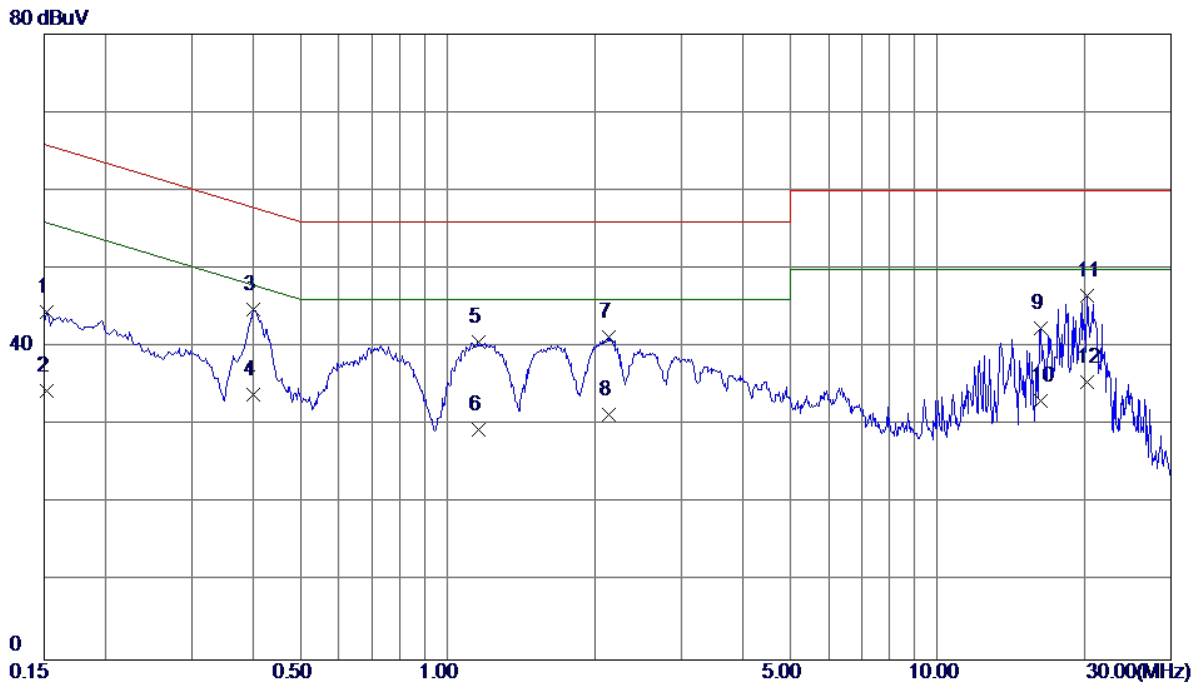

No.	Freq. MHz	Reading Level dBuV	Correct Factor dB	Measure ment dBuV	Limit dBuV	Margin dB	Detector
1	0.1522	34.84	9.64	44.48	65.88	-21.40	QP
2	0.1522	24.70	9.64	34.34	55.88	-21.54	AVG
3 *	0.4020	34.87	9.86	44.73	57.81	-13.08	QP
4	0.4020	24.10	9.86	33.96	47.81	-13.85	AVG
5	1.1535	30.49	10.20	40.69	56.00	-15.31	QP
6	1.1535	19.21	10.20	29.41	46.00	-16.59	AVG
7	2.1368	31.19	10.08	41.27	56.00	-14.73	QP
8	2.1368	21.30	10.08	31.38	46.00	-14.62	AVG
9	16.2285	31.66	10.68	42.34	60.00	-17.66	QP
10	16.2285	22.50	10.68	33.18	50.00	-16.82	AVG
11	20.2583	35.95	10.68	46.63	60.00	-13.37	QP
12	20.2583	24.90	10.68	35.58	50.00	-14.42	AVG

EUT	IP Phone	Model Name	F4G
Temperature	25°C	Relative Humidity	53%
Test Voltage	AC 230V/50Hz	Phase	Neutral
Test Mode	Adapter Supply:Handset		
Test Engineer	Treyy Chen		

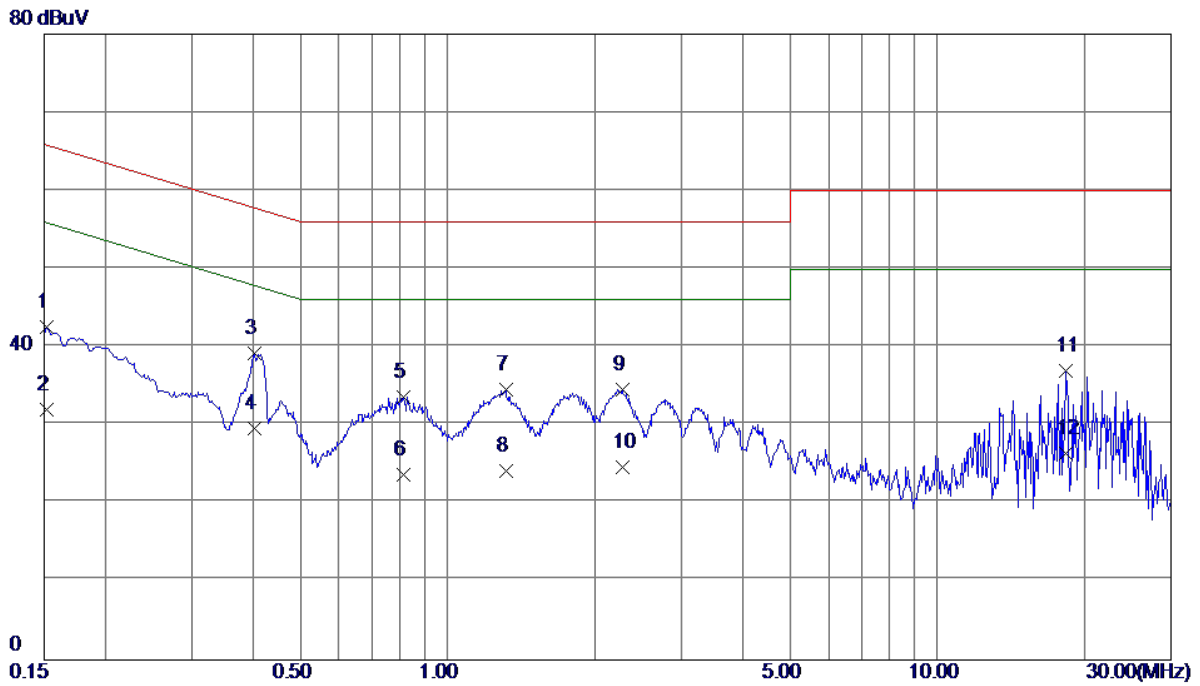

No.	Freq. MHz	Reading Level dBuV	Correct Factor dB	Measure ment dBuV	Limit dBuV	Margin dB	Detector
1	0.1522	32.96	9.54	42.50	65.88	-23.38	QP
2	0.1522	22.50	9.54	32.04	55.88	-23.84	AVG
3	0.4042	29.44	9.77	39.21	57.77	-18.56	QP
4 *	0.4042	19.80	9.77	29.57	47.77	-18.20	AVG
5	0.8137	23.79	9.88	33.67	56.00	-22.33	QP
6	0.8137	13.80	9.88	23.68	46.00	-22.32	AVG
7	1.3133	24.54	9.97	34.51	56.00	-21.49	QP
8	1.3133	14.21	9.97	24.18	46.00	-21.82	AVG
9	2.2718	24.44	10.08	34.52	56.00	-21.48	QP
10	2.2718	14.60	10.08	24.68	46.00	-21.32	AVG
11	18.2445	26.27	10.64	36.91	60.00	-23.09	QP
12	18.2445	15.70	10.64	26.34	50.00	-23.66	AVG

EUT	IP Phone	Model Name	F4G
Temperature	25°C	Relative Humidity	53%
Test Voltage	AC 230V/50Hz	Phase	Line
Test Mode	Adapter Supply:Earphone		
Test Engineer	Treyy Chen		

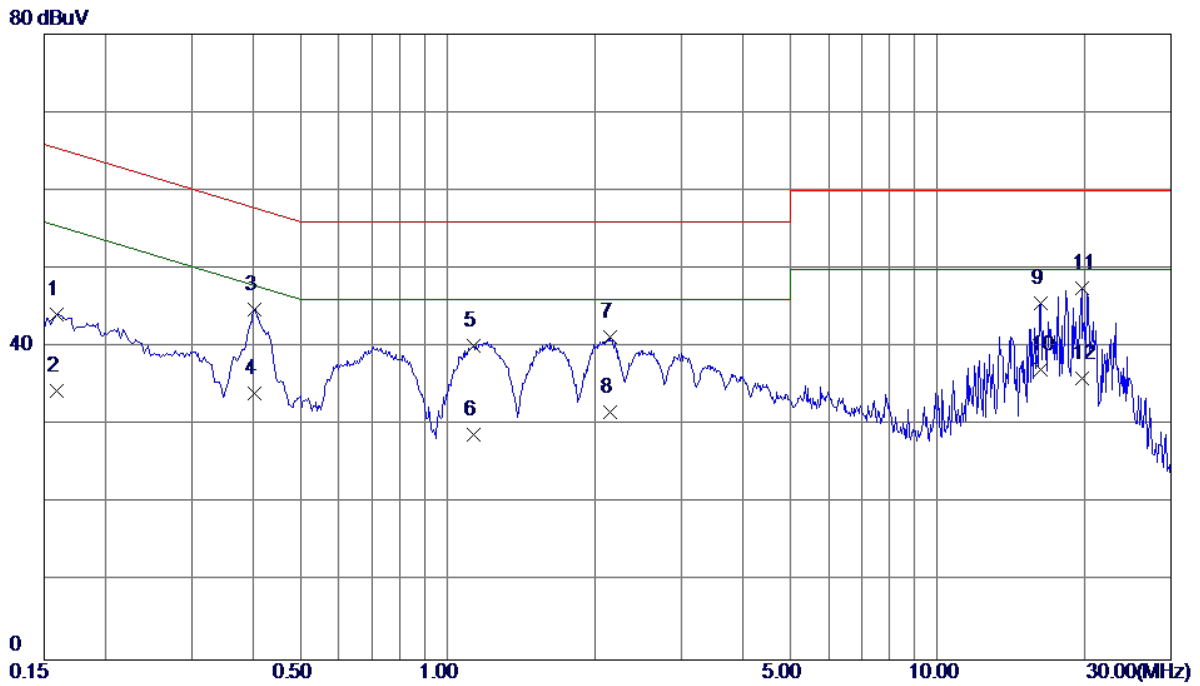

No.	Freq. MHz	Reading Level dBuV	Correct Factor dB	Measure ment dBuV	Limit dBuV	Margin dB	Detector
1	0.1590	34.47	9.65	44.12	65.52	-21.40	QP
2	0.1590	24.70	9.65	34.35	55.52	-21.17	AVG
3	0.4042	35.00	9.87	44.87	57.77	-12.90	QP
4	0.4042	24.20	9.87	34.07	47.77	-13.70	AVG
5	1.1286	29.93	10.19	40.12	56.00	-15.88	QP
6	1.1286	18.60	10.19	28.79	46.00	-17.21	AVG
7	2.1413	31.17	10.08	41.25	56.00	-14.75	QP
8	2.1413	21.60	10.08	31.68	46.00	-14.32	AVG
9	16.2285	34.90	10.68	45.58	60.00	-14.42	QP
10	16.2285	26.40	10.68	37.08	50.00	-12.92	AVG
11 *	19.7093	36.77	10.68	47.45	60.00	-12.55	QP
12	19.7093	25.30	10.68	35.98	50.00	-14.02	AVG

EUT	IP Phone	Model Name	F4G
Temperature	25°C	Relative Humidity	53%
Test Voltage	AC 230V/50Hz	Phase	Neutral
Test Mode	Adapter Supply:Earphone		
Test Engineer	Treyy Chen		

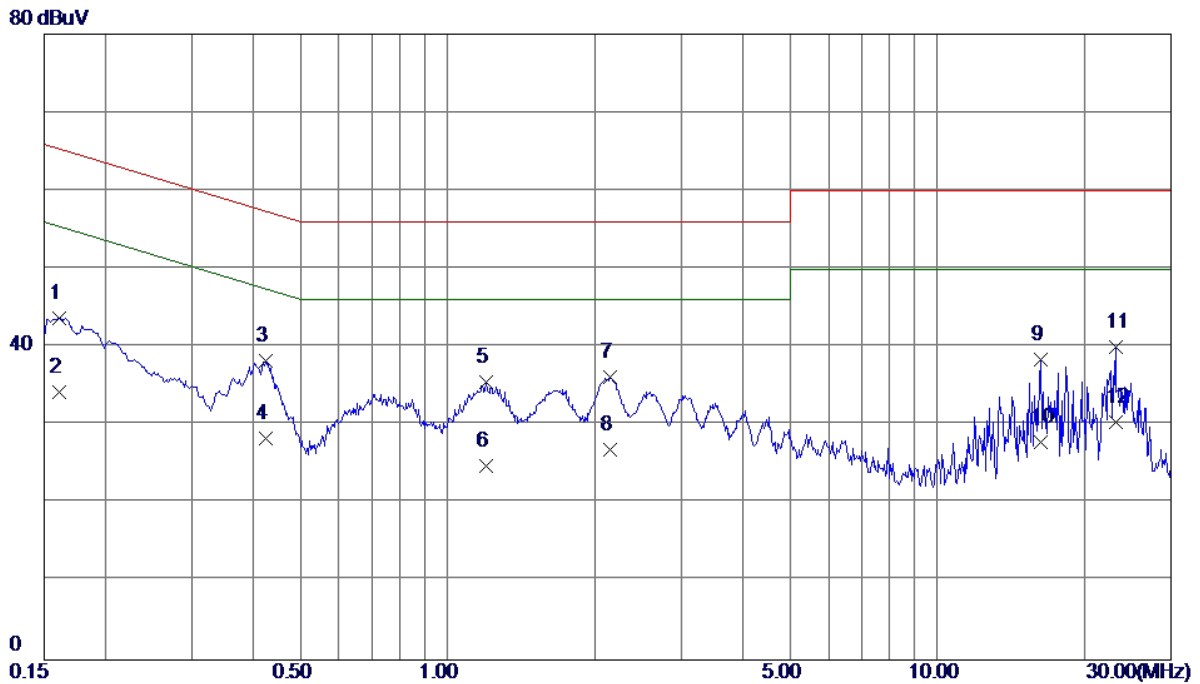

No.	Freq. MHz	Reading Level dBuV	Correct Factor dB	Measurement dBuV	Limit dBuV	Margin dB	Detector
1	0.1613	34.18	9.55	43.73	65.40	-21.67	QP
2	0.1613	24.70	9.55	34.25	55.40	-21.15	AVG
3	0.4245	28.46	9.77	38.23	57.36	-19.13	QP
4 *	0.4245	18.50	9.77	28.27	47.36	-19.09	AVG
5	1.1985	25.58	9.93	35.51	56.00	-20.49	QP
6	1.1985	14.90	9.93	24.83	46.00	-21.17	AVG
7	2.1458	26.02	10.08	36.10	56.00	-19.90	QP
8	2.1458	16.80	10.08	26.88	46.00	-19.12	AVG
9	16.2285	27.84	10.60	38.44	60.00	-21.56	QP
10	16.2285	17.20	10.60	27.80	50.00	-22.20	AVG
11	23.1293	29.30	10.74	40.04	60.00	-19.96	QP
12	23.1293	19.60	10.74	30.34	50.00	-19.66	AVG

4.3 ASYMMETRIC MODE CONDUCTED EMISSIONS TEST

4.3.1 LIMITS

Requirements for asymmetric mode conducted emissions from Class A equipment

Table clause	Frequency range MHz	Coupling device	Detector type / Bandwidth	Class A voltage limits dB(μV)	Class A current limits dB(μV)
A10.1	0.15 – 0.5	AAN	Quasi Peak / 9 kHz	97 – 87	n/a
	0.5 – 30			87	
	0.15 – 0.5	AAN	Average / 9 kHz	84 – 74	
	0.5 – 30			74	
A10.2	0.15 – 0.5	CVP and current probe	Quasi Peak / 9 kHz	97 – 87	53 – 43
	0.5 – 30			87	43
	0.15 – 0.5	CVP and current probe	Average / 9 kHz	84 – 74	40 – 30
	0.5 – 30			74	30
A10.3	0.15 – 0.5	Current probe	Quasi Peak / 9 kHz	n/a	53 – 43
	0.5 – 30				43
	0.15 – 0.5	Current probe	Average / 9 kHz		40 – 30
	0.5 – 30				30

Requirements for asymmetric mode conducted emissions from Class B equipment

Table clause	Frequency range MHz	Coupling device	Detector type / Bandwidth	Class B voltage limits dB(μV)	Class B current limits dB(μV)
A11.1	0.15 – 0.5	AAN	Quasi Peak / 9 kHz	84 – 74	n/a
	0.5 – 30			74	
	0.15 – 0.5	AAN	Average / 9 kHz	74 – 64	
	0.5 – 30			64	
A11.2	0.15 – 0.5	CVP and current probe	Quasi Peak / 9 kHz	84 – 74	40 – 30
	0.5 – 30			74	30
	0.15 – 0.5	CVP and current probe	Average / 9 kHz	74 – 64	30 – 20
	0.5 – 30			64	20
A11.3	0.15 – 0.5	Current probe	Quasi Peak / 9 kHz	n/a	40 – 30
	0.5 – 30				30
	0.15 – 0.5	Current probe	Average / 9 kHz		30 – 20
	0.5 – 30				20

NOTE:

(1) The test result calculated as following:

Measurement Value = Reading Level + Correct Factor

Correct Factor = Insertion Loss + Cable Loss + Attenuator Factor(if use)

Margin Level = Measurement Value – Limit Value

4.3.2 MEASUREMENT INSTRUMENTS LIST

Item	Kind of Equipment	Manufacturer	Type No.	Serial No.	Calibrated until
1	50Ω Terminator	SHX	TF2-3G-A	8122901	Mar. 27, 2017
2	TWO-LINE V-NETWORK	R&S	ENV216	100526	Mar. 27, 2017
3	EMI Test Receiver	R&S	ESR3	101862	Sep. 04, 2017
4	Artificial-Mains Network	SCHWARZBECK	NSLK 8127	8127685	Sep. 04, 2017
5	Cable	N/A	RG400 12m	N/A	Mar. 10, 2017
6	Measurement Software	Farad	EZ-EMC Ver.NB-03A 1-01	N/A	N/A
7	ISN	Teseq GmbH	ISN T8	30833	Oct. 21, 2017

Remark: "N/A" denotes no model name, no serial No. or no calibration specified.

All calibration period of equipment list is one year.

4.3.3 TEST PROCEDURE

- a. The EUT was placed 0.8 meters from the horizontal ground plane with EUT being connected to the power mains through a line impedance stabilization network (LISN). All other support equipment powered from additional LISN(s). The LISN provide 50 Ohm/ 50uH of coupling impedance for the measuring instrument.
- b. Interconnecting cables that hang closer than 40 cm to the ground plane shall be folded back and forth in the center forming a bundle 30 to 40 cm long.
- c. I/O cables that are not connected to a peripheral shall be bundled in the center. The end of the cable may be terminated, if required, using the correct terminating impedance. The overall length shall not exceed 1 m.
- d. For the actual test configuration, please refer to the related Item –EUT Test Photos.
- e. **AAN, CP or CVP** at least 80 cm from nearest part of EUT chassis.

NOTE:

- f. The communication function of EUT was executed and AAN was connected between EUT and associated equipment and the AAN was connected directly to reference ground plane.
Measure the voltage at the measurement port of the AAN
Correct the measured voltage by adding the AAN voltage division factor
Compare the corrected voltage with the limit(**For AAN**)
- g Measure the current with a current probe and compare to the current limit(**For CP**)
- h The current shall be measured with the current probe and the results compared with the current limits.
The voltage measured shall be corrected at each frequency of interest as follows:
- if the current margin with respect to the current limit is ≤ 6 dB, the actual current margin shall be subtracted from the measured voltage:
-if the current margin with respect to the current limit is >6 dB, 6 dB shall be subtracted from the measured voltage.
The adjusted voltage shall be compared with the applicable voltage limit.
Both the measured current and the corrected voltage shall be below the applicable current and voltage limits at all frequencies for the EUT to be deemed compliant with this publication.(**For CVP**)

4.3.4 DEVIATION FROM TEST STANDARD

No deviation

4.3.5 TEST SETUP

a) Cable Type: Balanced Unscreened, Screened or Coaxial

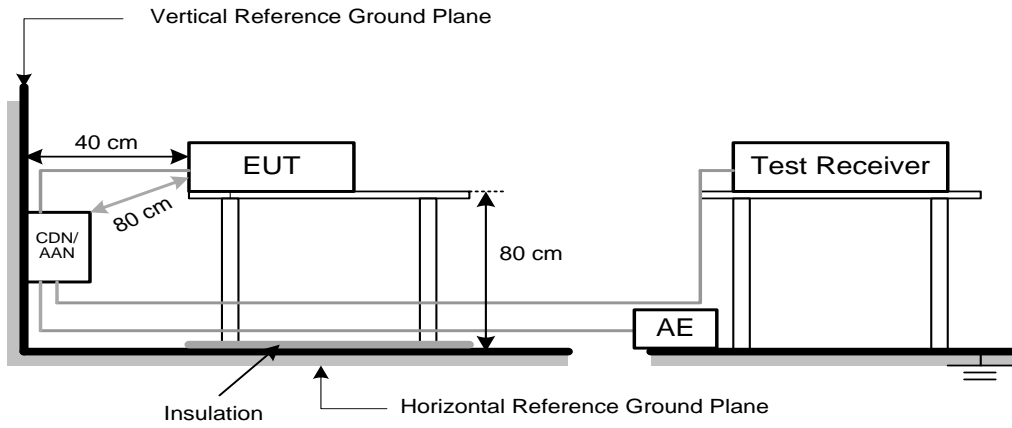

b) Cable Type: Screened or Coaxial

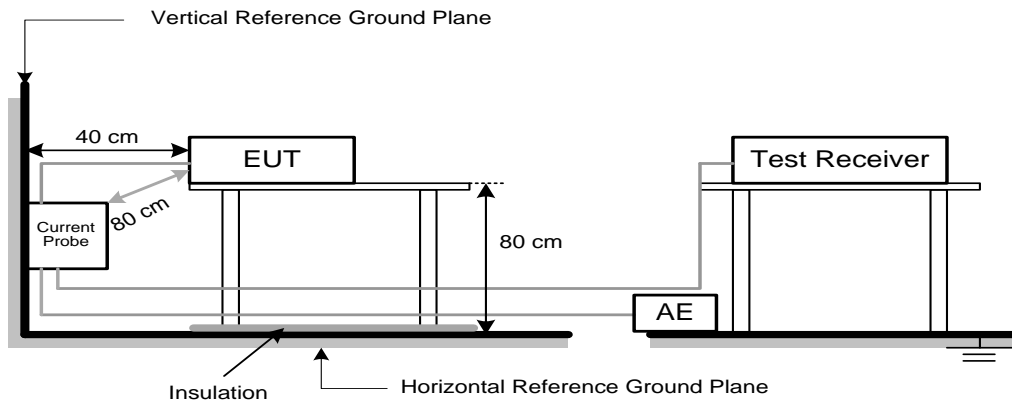

c) Cable Type: Balanced Unscreened, Unbalanced

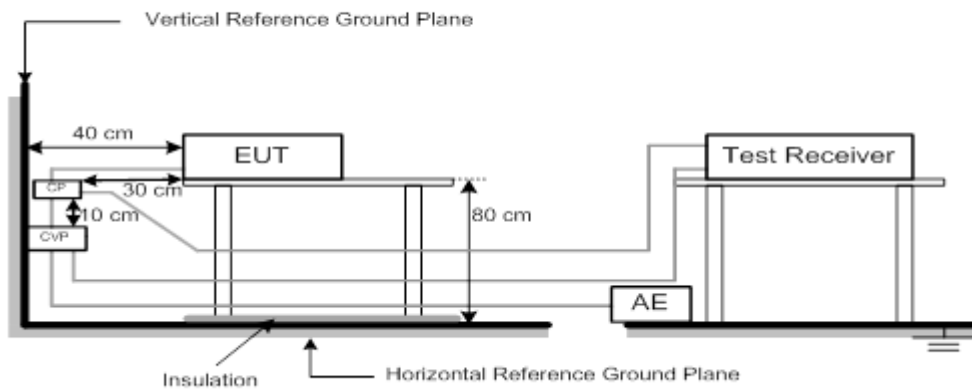

4.3.6 TEST RESULTS

EUT	IP Phone	Model Name	F4G
Temperature	25°C	Relative Humidity	53%
Test Voltage	AC 230V/50Hz		
Test Mode	Adapter Supply:WAN 100Mbps		
Test Engineer	Treyy Chen		

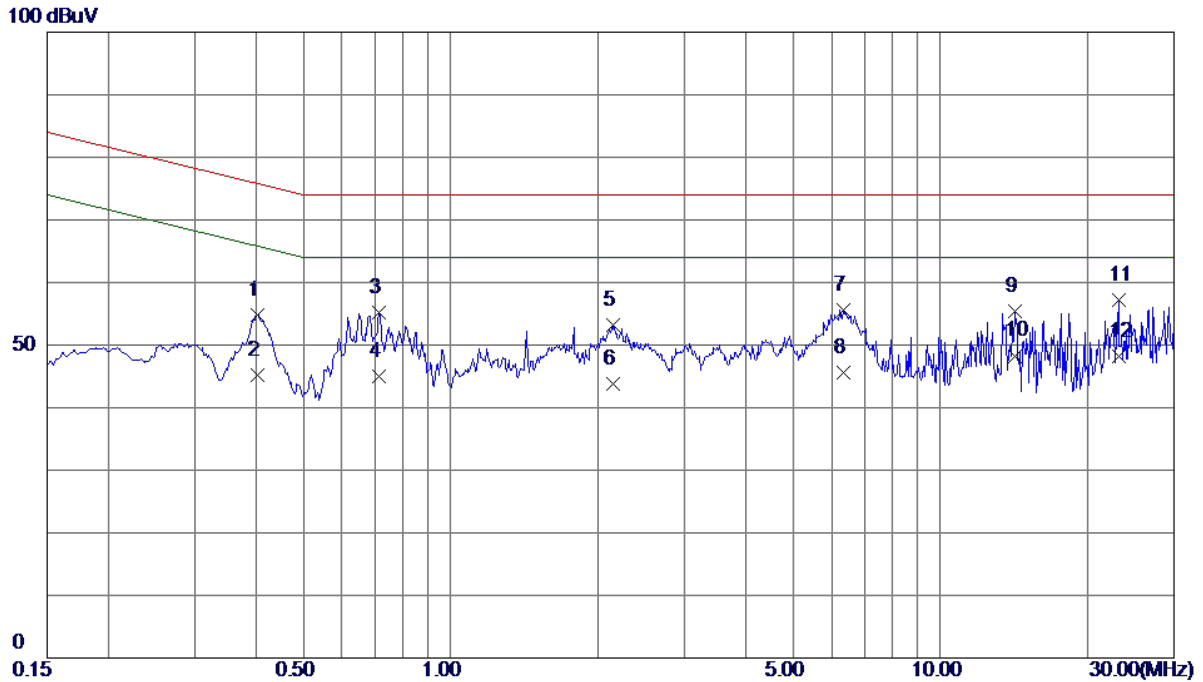

No.	Freq. MHz	Reading Level dBuV	Correct Factor dB	Measure ment dBuV	Limit dBuV	Margin dB	Detector
1	0.4042	45.13	9.67	54.80	75.77	-20.97	QP
2	0.4042	35.50	9.67	45.17	65.77	-20.60	AVG
3	0.7147	45.42	9.76	55.18	74.00	-18.82	QP
4	0.7147	35.20	9.76	44.96	64.00	-19.04	AVG
5	2.1435	43.38	9.89	53.27	74.00	-20.73	QP
6	2.1435	34.00	9.89	43.89	64.00	-20.11	AVG
7	6.3487	45.53	10.05	55.58	74.00	-18.42	QP
8	6.3487	35.60	10.05	45.65	64.00	-18.35	AVG
9	14.2125	45.09	10.30	55.39	74.00	-18.61	QP
10 *	14.2125	38.00	10.30	48.30	64.00	-15.70	AVG
11	23.1293	46.71	10.58	57.29	74.00	-16.71	QP
12	23.1293	37.71	10.58	48.29	64.00	-15.71	AVG

EUT	IP Phone	Model Name	F4G
Temperature	25°C	Relative Humidity	53%
Test Voltage	AC 230V/50Hz		
Test Mode	Adapter Supply:WAN 10Mbps		
Test Engineer	Treyy Chen		

100 dBuV

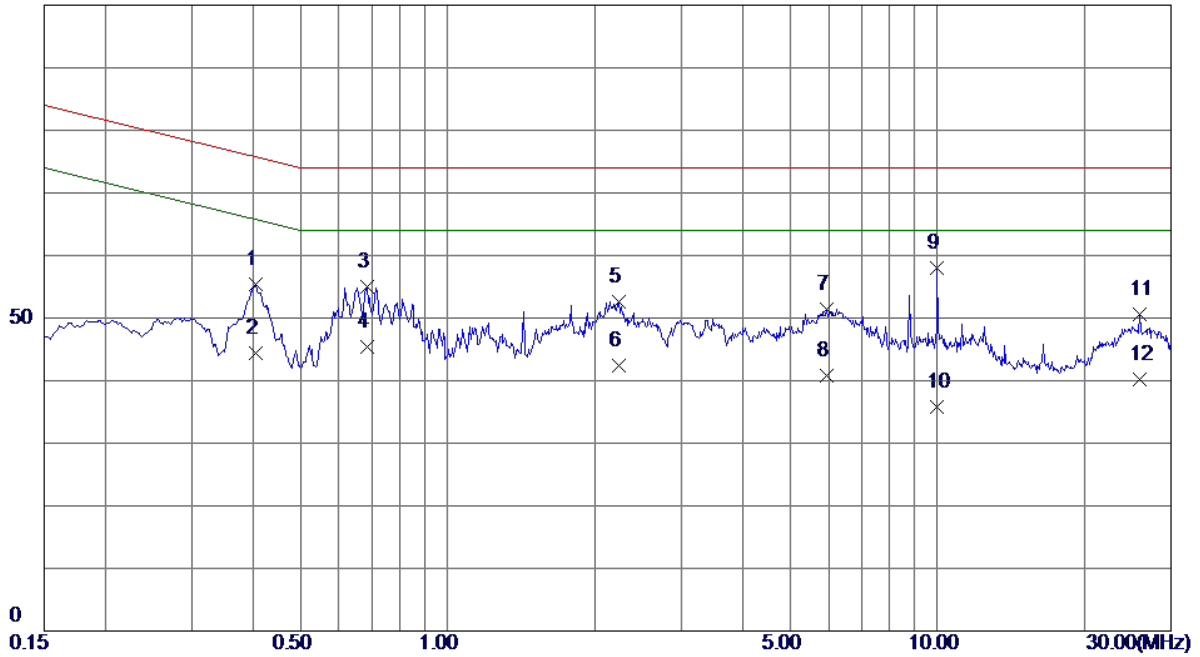

No.	Freq. MHz	Reading Level dBuV	Correct Factor dB	Measure ment dBuV	Limit dBuV	Margin dB	Detector
1	0.4065	45.72	9.67	55.39	75.72	-20.33	QP
2	0.4065	34.80	9.67	44.47	65.72	-21.25	AVG
3	0.6832	45.23	9.76	54.99	74.00	-19.01	QP
4	0.6832	35.59	9.76	45.35	64.00	-18.65	AVG
5	2.2313	42.72	9.89	52.61	74.00	-21.39	QP
6	2.2313	32.50	9.89	42.39	64.00	-21.61	AVG
7	5.9393	41.42	10.04	51.46	74.00	-22.54	QP
8	5.9393	30.69	10.04	40.73	64.00	-23.27	AVG
9 *	10.0004	47.80	10.16	57.96	74.00	-16.04	QP
10	10.0004	25.70	10.16	35.86	64.00	-28.14	AVG
11	25.8720	39.90	10.66	50.56	74.00	-23.44	QP
12	25.8720	29.60	10.66	40.26	64.00	-23.74	AVG

EUT	IP Phone	Model Name	F4G
Temperature	25°C	Relative Humidity	53%
Test Voltage	AC 230V/50Hz		
Test Mode	Adapter Supply:LAN 100Mbps		
Test Engineer	Treey Chen		

100 dBuV

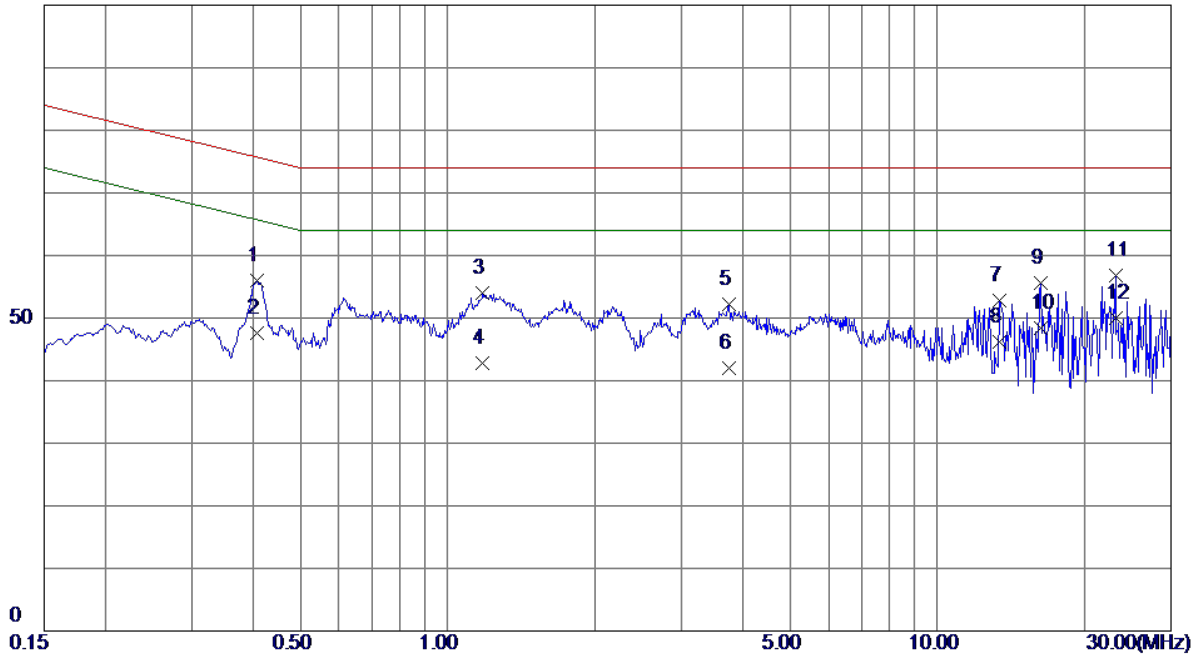

No.	Freq. MHz	Reading Level dBuV	Correct Factor dB	Measure ment dBuV	Limit dBuV	Margin dB	Detector
1	0.4087	46.30	9.67	55.97	75.67	-19.70	QP
2	0.4087	38.00	9.67	47.67	65.67	-18.00	AVG
3	1.1782	44.08	9.84	53.92	74.00	-20.08	QP
4	1.1782	32.90	9.84	42.74	64.00	-21.26	AVG
5	3.7478	42.22	9.95	52.17	74.00	-21.83	QP
6	3.7478	32.10	9.95	42.05	64.00	-21.95	AVG
7	13.4183	42.52	10.28	52.80	74.00	-21.20	QP
8	13.4183	35.99	10.28	46.27	64.00	-17.73	AVG
9	16.2285	45.24	10.37	55.61	74.00	-18.39	QP
10	16.2285	37.98	10.37	48.35	64.00	-15.65	AVG
11	23.1293	46.25	10.58	56.83	74.00	-17.17	QP
12 *	23.1293	39.51	10.58	50.09	64.00	-13.91	AVG

EUT	IP Phone	Model Name	F4G
Temperature	25°C	Relative Humidity	53%
Test Voltage	AC 230V/50Hz		
Test Mode	Adapter Supply:LAN 10Mbps		
Test Engineer	Treay Chen		

100 dBuV

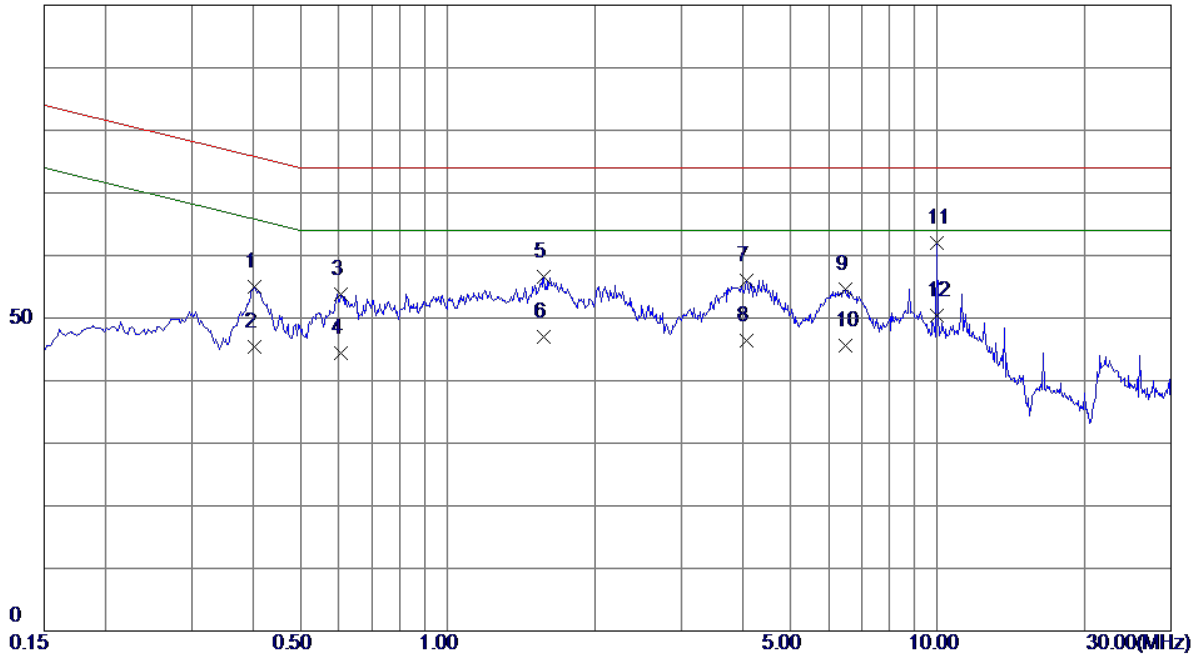

No.	Freq. MHz	Reading Level dBuV	Correct Factor dB	Measure ment dBuV	Limit dBuV	Margin dB	Detector
1	0.4042	45.25	9.67	54.92	75.77	-20.85	QP
2	0.4042	35.80	9.67	45.47	65.77	-20.30	AVG
3	0.6066	44.13	9.74	53.87	74.00	-20.13	QP
4	0.6066	34.69	9.74	44.43	64.00	-19.57	AVG
5	1.5720	46.65	9.86	56.51	74.00	-17.49	QP
6	1.5720	37.20	9.86	47.06	64.00	-16.94	AVG
7	4.0695	46.06	9.96	56.02	74.00	-17.98	QP
8	4.0695	36.51	9.96	46.47	64.00	-17.53	AVG
9	6.4838	44.57	10.06	54.63	74.00	-19.37	QP
10	6.4838	35.59	10.06	45.65	64.00	-18.35	AVG
11 *	10.0004	51.82	10.16	61.98	74.00	-12.02	QP
12	10.0004	40.30	10.16	50.46	64.00	-13.54	AVG

EUT	IP Phone	Model Name	F4G
Temperature	25°C	Relative Humidity	53%
Test Voltage	PoE 48V		
Test Mode	PoE Supply:WAN 100Mbps		
Test Engineer	Treyy Chen		

100 dBuV

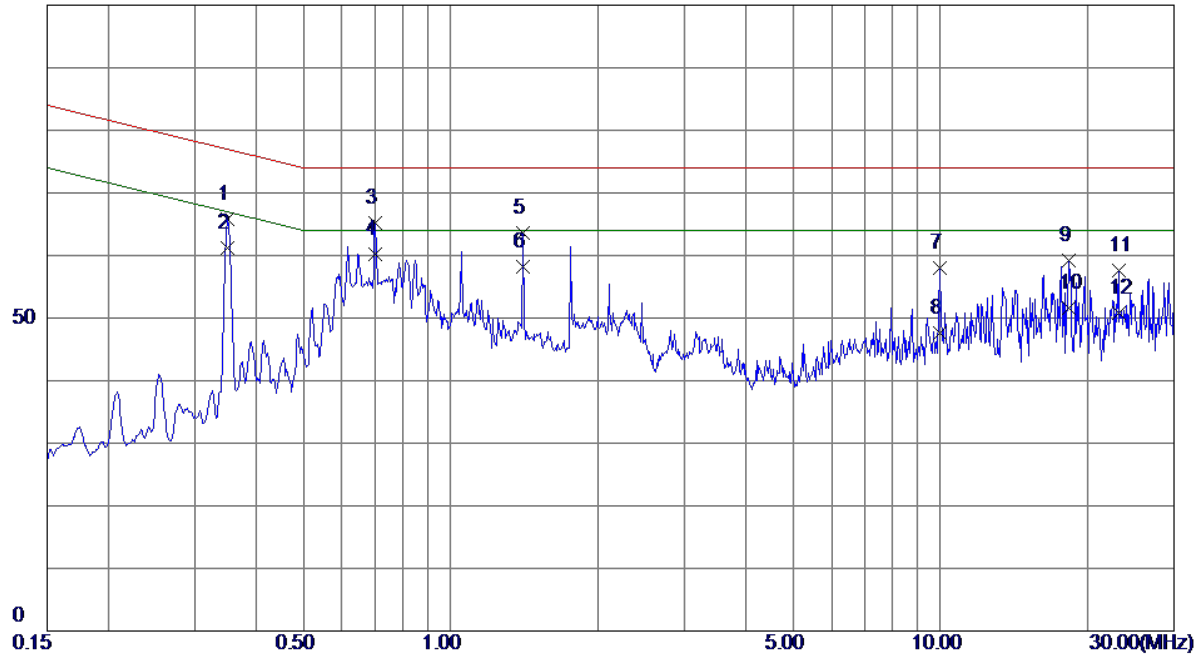

No.	Freq. MHz	Reading Level dBuV	Correct Factor dB	Measurement dBuV	Limit dBuV	Margin dB	Detector
1	0.3502	56.12	9.64	65.76	76.96	-11.20	QP
2	0.3502	51.50	9.64	61.14	66.96	-5.82	AVG
3	0.7012	55.43	9.76	65.19	74.00	-8.81	QP
4 *	0.7012	50.40	9.76	60.16	64.00	-3.84	AVG
5	1.4032	53.71	9.85	63.56	74.00	-10.44	QP
6	1.4032	48.30	9.85	58.15	64.00	-5.85	AVG
7	10.0004	47.78	10.16	57.94	74.00	-16.06	QP
8	10.0004	37.50	10.16	47.66	64.00	-16.34	AVG
9	18.2445	48.71	10.44	59.15	74.00	-14.85	QP
10	18.2445	41.10	10.44	51.54	64.00	-12.46	AVG
11	23.1293	47.01	10.58	57.59	74.00	-16.41	QP
12	23.1293	40.31	10.58	50.89	64.00	-13.11	AVG

EUT	IP Phone	Model Name	F4G
Temperature	25°C	Relative Humidity	53%
Test Voltage	PoE 48V		
Test Mode	PoE Supply:WAN 10Mbps		
Test Engineer	Treey Chen		

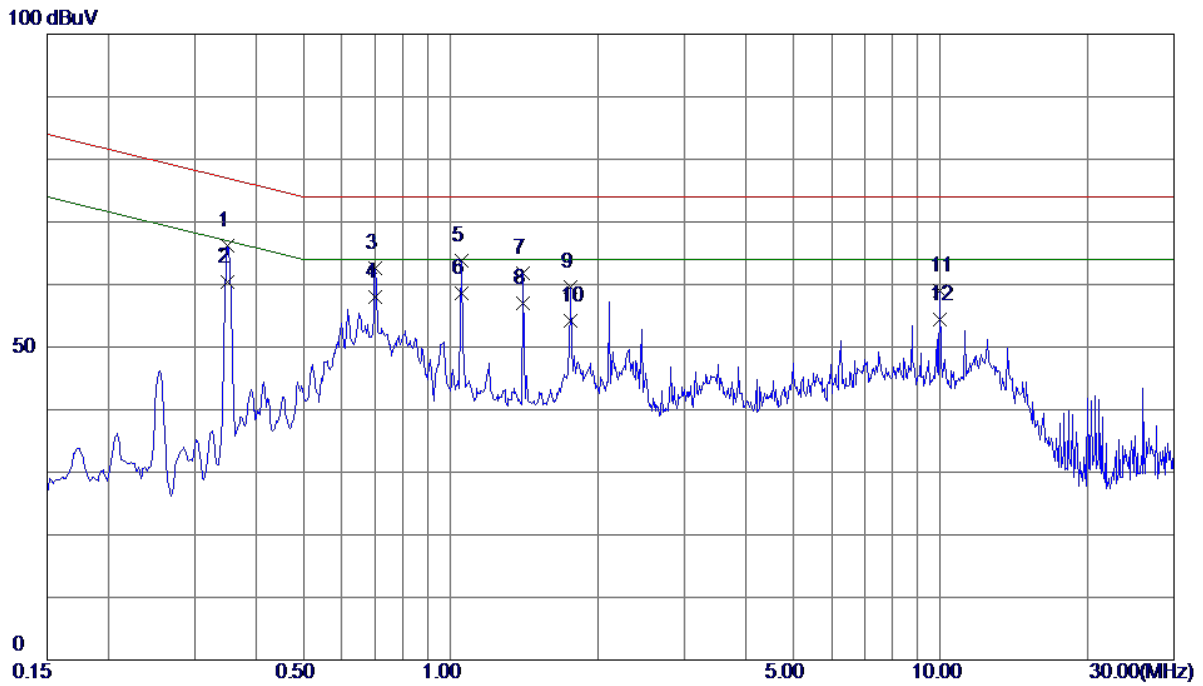

No.	Freq. MHz	Reading Level dBuV	Correct Factor dB	Measurement dBuV	Limit dBuV	Margin dB	Detector
1	0.3502	56.51	9.64	66.15	76.96	-10.81	QP
2	0.3502	50.80	9.64	60.44	66.96	-6.52	AVG
3	0.7012	52.88	9.76	62.64	74.00	-11.36	QP
4	0.7012	48.30	9.76	58.06	64.00	-5.94	AVG
5	1.0544	53.93	9.83	63.76	74.00	-10.24	QP
6 *	1.0544	48.80	9.83	58.63	64.00	-5.37	AVG
7	1.4053	51.91	9.85	61.76	74.00	-12.24	QP
8	1.4053	47.10	9.85	56.95	64.00	-7.05	AVG
9	1.7563	49.72	9.87	59.59	74.00	-14.41	QP
10	1.7563	44.30	9.87	54.17	64.00	-9.83	AVG
11	10.0004	48.89	10.16	59.05	74.00	-14.95	QP
12	10.0004	44.20	10.16	54.36	64.00	-9.64	AVG

EUT	IP Phone	Model Name	F4G
Temperature	25°C	Relative Humidity	53%
Test Voltage	PoE 48V		
Test Mode	PoE Supply:LAN 100Mbps		
Test Engineer	Treyy Chen		

100 dBuV

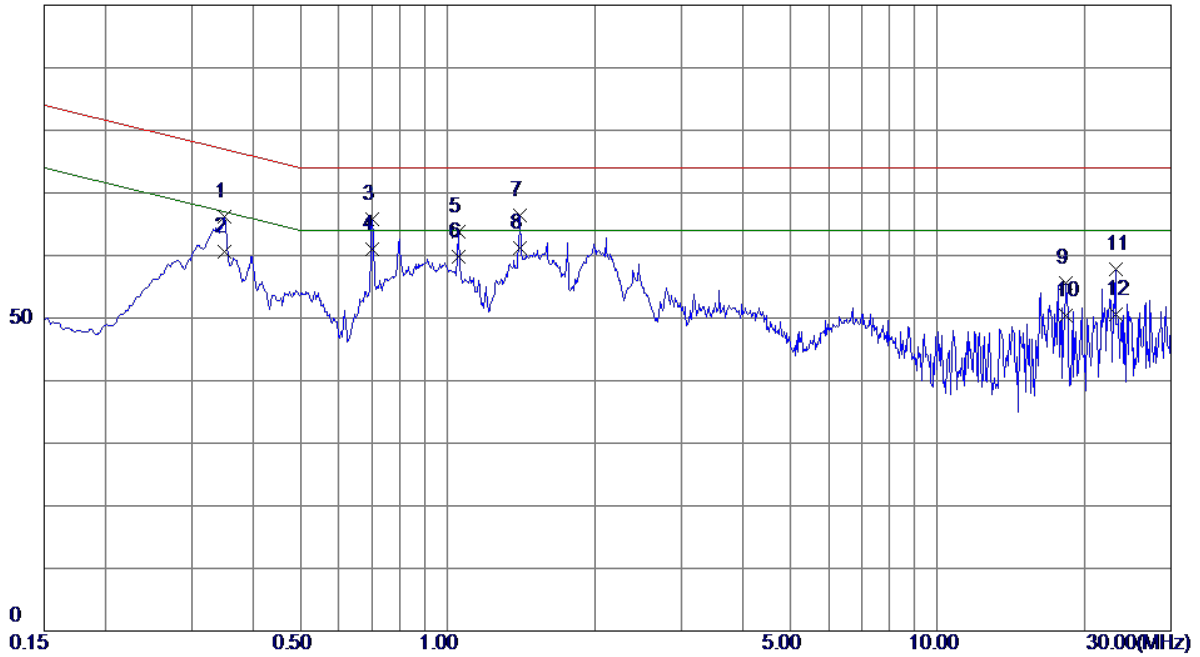

No.	Freq. MHz	Reading Level dBuV	Correct Factor dB	Measure ment dBuV	Limit dBuV	Margin dB	Detector
1	0.3502	56.53	9.64	66.17	76.96	-10.79	QP
2	0.3502	50.90	9.64	60.54	66.96	-6.42	AVG
3	0.7012	56.10	9.76	65.86	74.00	-8.14	QP
4	0.7012	51.20	9.76	60.96	64.00	-3.04	AVG
5	1.0522	53.95	9.83	63.78	74.00	-10.22	QP
6	1.0522	49.90	9.83	59.73	64.00	-4.27	AVG
7	1.4033	56.48	9.85	66.33	74.00	-7.67	QP
8 *	1.4033	51.40	9.85	61.25	64.00	-2.75	AVG
9	18.2445	45.25	10.44	55.69	74.00	-18.31	QP
10	18.2445	40.00	10.44	50.44	64.00	-13.56	AVG
11	23.1293	47.24	10.58	57.82	74.00	-16.18	QP
12	23.1293	40.01	10.58	50.59	64.00	-13.41	AVG

EUT	IP Phone	Model Name	F4G
Temperature	25°C	Relative Humidity	53%
Test Voltage	PoE 48V		
Test Mode	PoE Supply:LAN 10Mbps		
Test Engineer	Treyy Chen		

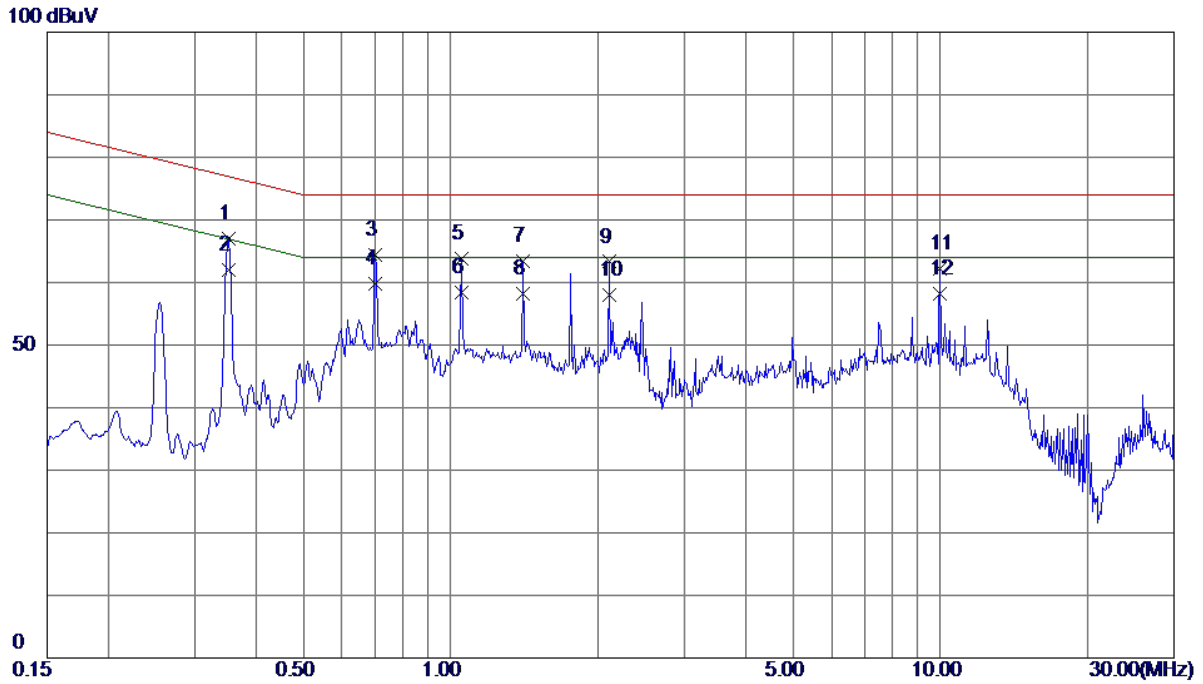

No.	Freq. MHz	Reading Level dBuV	Correct Factor dB	Measure ment dBuV	Limit dBuV	Margin dB	Detector
1	0.3523	57.45	9.64	67.09	76.91	-9.82	QP
2	0.3523	52.40	9.64	62.04	66.91	-4.87	AVG
3	0.7012	54.73	9.76	64.49	74.00	-9.51	QP
4 *	0.7012	50.00	9.76	59.76	64.00	-4.24	AVG
5	1.0544	53.95	9.83	63.78	74.00	-10.22	QP
6	1.0544	48.60	9.83	58.43	64.00	-5.57	AVG
7	1.4052	53.64	9.85	63.49	74.00	-10.51	QP
8	1.4052	48.30	9.85	58.15	64.00	-5.85	AVG
9	2.1074	53.42	9.88	63.30	74.00	-10.70	QP
10	2.1074	48.11	9.88	57.99	64.00	-6.01	AVG
11	10.0004	52.09	10.16	62.25	74.00	-11.75	QP
12	10.0004	48.10	10.16	58.26	64.00	-5.74	AVG

4.4 HARMONIC CURRENT EMISSIONS TEST

4.4.1 LIMITS

EN 61000-3-2						
Equipment Category	Harmonic Order n	Max. Permissible Harmonic Current A	Equipment Category	Harmonic Order n	Max. Permissible Harmonic Current A mA/w	
Class A	Odd Harmonics		Class D	Odd Harmonics only		
	3	2.30		3	2.30	3.4
	5	1.14		5	1.14	1.9
	7	0.77		7	0.77	1.0
	9	0.40		9	0.40	0.5
	11	0.33		11	0.33	0.35
	13	0.21		13	0.21	0.30
	15≤n≤39	0.15 x 15/n		15≤n≤39	0.15 x 15/n	3.85/n
	Even Harmonics					
	2	1.08				
	4	0.43				
	6	0.30				
	8≤n≤40	0.23 x 8/n				

4.4.2 MEASUREMENT INSTRUMENTS LIST

Item	Kind of Equipment	Manufacturer	Type No.	Serial No.	Calibrated until
1	Harmonics and Flicker Analyzer	California Instruments	PACS-1	72344	Jul. 26, 2017
2	3KVA AC Power source	California Instruments	3001ix	56309	Jul. 26, 2017
3	Measurement Software	California	CTS4.0 Version 4.9	N/A	N/A

Remark: "N/A" denotes no model name, no serial No. or no calibration specified.
All calibration period of equipment list is one year.

4.4.3 TEST PROCEDURE

- a. The EUT was placed on the top of a wooden table 0.8 meters above the ground and operated to produce the maximum harmonic components under normal operating conditions.
- b. The classification of EUT is according to of EN 61000-3-2. The EUT is classified as follows:
 - Class A: Balanced three-phase equipment, Household appliances excluding equipment as Class D, Tools excluding portable tools, Dimmers for incandescent lamps, audio equipment, equipment not specified in one of the three other classes.
 - Class B: Portable tools: Arc welding equipment which is not professional equipment.
 - Class C: Lighting equipment.
 - Class D: Equipment having a specified power less than or equal to 600 W of the following types: Personal computers and personal computer monitors and television receivers.
- c. The correspondent test program of test instrument to measure the current harmonics emanated from EUT is chosen. The measure time shall be not less than the time necessary for the EUT to be exercised.

4.4.4 DEVIATION FROM TEST STANDARD

No deviation

4.4.5 TEST SETUP

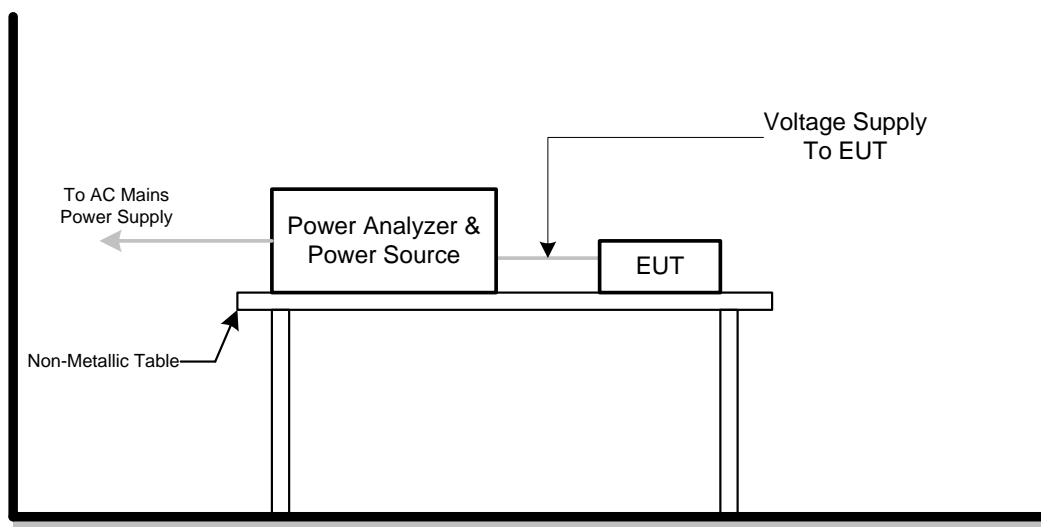

4.4.6 TEST RESULTS

Harmonic - Class A			
EUT	IP Phone	Model Name	F4G
Temperature	25°C	Relative Humidity	55%
Test Voltage	AC 230V/50Hz		
Test Mode	Adapter Supply:Handfree		

Current & voltage waveforms

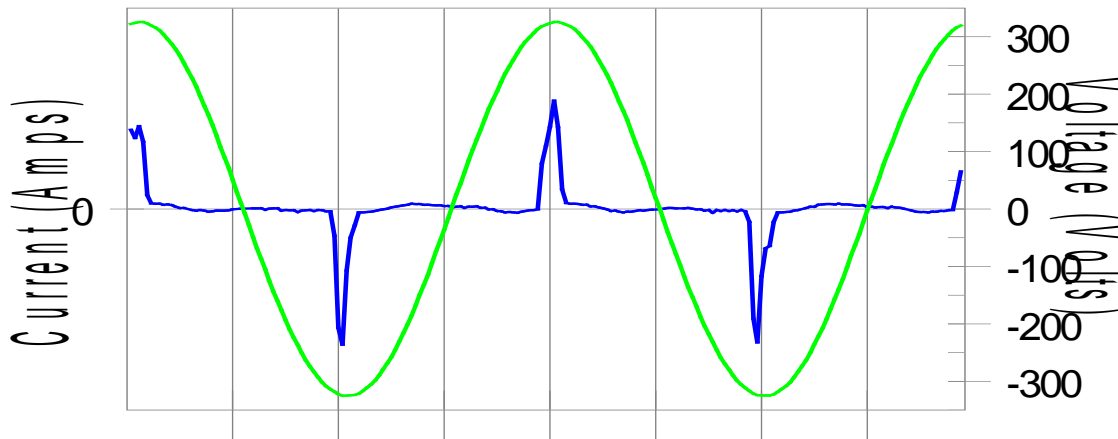

Harmonics and Class A limit line European Limits

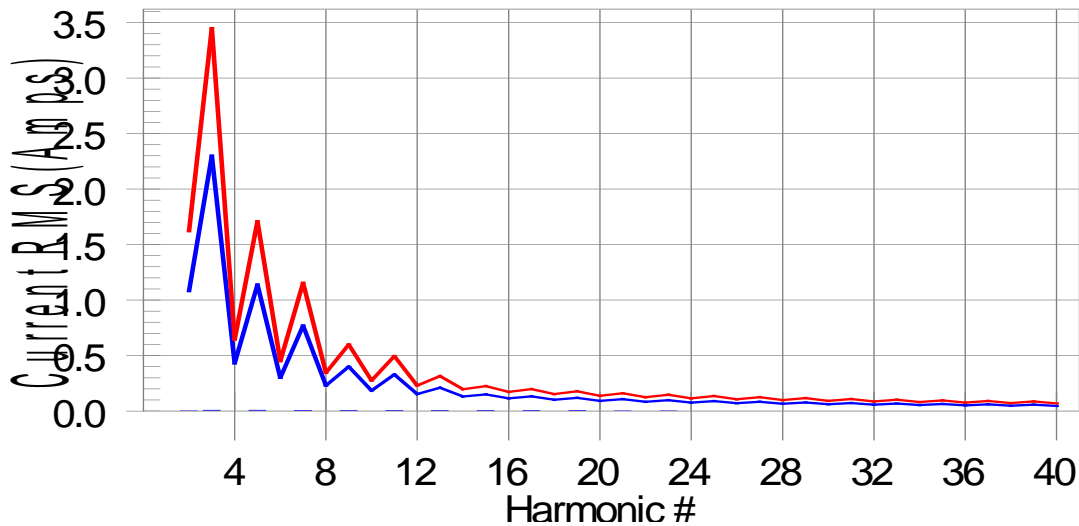

Test result: Pass Worst harmonic was #11 with 1.2% of the limit.

Current Test Result Summary (Run time)			
EUT	IP Phone	Model Name	F4G
Temperature	25°C	Relative Humidity	55%
Test Voltage	AC 230V/50Hz		
Test Mode	Adapter Supply:Handfree		

Highest parameter values during test:

V_RMS (Volts): 230.00	Frequency(Hz): 50.00
I_Peak (Amps): 0.143	I_RMS (Amps): 0.023
I_Fund (Amps): 0.009	Crest Factor: 6.900
Power (Watts): 2.0	Power Factor: 0.448

Harm#	Harms(avg)	100%Limit	%of Limit	Harms(max)	150%Limit	%of Limit	Status
2	0.001	1.080	N/A	0.001	1.620	N/A	Pass
3	0.008	2.300	0.3	0.010	3.450	0.3	Pass
4	0.001	0.430	N/A	0.001	0.645	N/A	Pass
5	0.007	1.140	0.7	0.008	1.710	0.5	Pass
6	0.000	0.300	N/A	0.000	0.450	N/A	Pass
7	0.007	0.770	0.9	0.008	1.155	0.7	Pass
8	0.000	0.230	N/A	0.000	0.345	N/A	Pass
9	0.006	0.400	1.6	0.007	0.600	1.2	Pass
10	0.000	0.184	N/A	0.000	0.276	N/A	Pass
11	0.006	0.330	1.7	0.006	0.495	1.2	Pass
12	0.000	0.153	N/A	0.000	0.230	N/A	Pass
13	0.005	0.210	N/A	0.005	0.315	N/A	Pass
14	0.000	0.131	N/A	0.000	0.197	N/A	Pass
15	0.004	0.150	N/A	0.004	0.225	N/A	Pass
16	0.000	0.115	N/A	0.000	0.173	N/A	Pass
17	0.003	0.132	N/A	0.003	0.198	N/A	Pass
18	0.000	0.102	N/A	0.000	0.153	N/A	Pass
19	0.002	0.118	N/A	0.003	0.178	N/A	Pass
20	0.000	0.092	N/A	0.000	0.138	N/A	Pass
21	0.002	0.107	N/A	0.002	0.161	N/A	Pass
22	0.000	0.084	N/A	0.000	0.125	N/A	Pass
23	0.001	0.098	N/A	0.001	0.147	N/A	Pass
24	0.000	0.077	N/A	0.000	0.115	N/A	Pass
25	0.001	0.090	N/A	0.001	0.135	N/A	Pass
26	0.000	0.071	N/A	0.000	0.107	N/A	Pass
27	0.001	0.083	N/A	0.001	0.125	N/A	Pass
28	0.000	0.066	N/A	0.000	0.099	N/A	Pass
29	0.001	0.078	N/A	0.001	0.116	N/A	Pass
30	0.000	0.061	N/A	0.000	0.092	N/A	Pass
31	0.001	0.073	N/A	0.001	0.109	N/A	Pass
32	0.000	0.058	N/A	0.000	0.086	N/A	Pass
33	0.001	0.068	N/A	0.001	0.102	N/A	Pass
34	0.000	0.054	N/A	0.000	0.081	N/A	Pass
35	0.001	0.064	N/A	0.001	0.096	N/A	Pass
36	0.000	0.051	N/A	0.000	0.077	N/A	Pass
37	0.000	0.061	N/A	0.000	0.091	N/A	Pass
38	0.000	0.048	N/A	0.000	0.073	N/A	Pass
39	0.000	0.058	N/A	0.000	0.087	N/A	Pass
40	0.000	0.046	N/A	0.000	0.069	N/A	Pass

Voltage Source Verification Data (Run time)			
EUT	IP Phone	Model Name	F4G
Temperature	25°C	Relative Humidity	55%
Test Voltage	AC 230V/50Hz		
Test Mode	Adapter Supply:Handfree		

Highest parameter values during test:

Voltage (Vrms):230.00	Frequency(Hz): 50.00
I_Peak (Amps):0.143	I_RMS (Amps): 0.023
I_Fund (Amps):0.009	Crest Factor: 6.900
Power (Watts): 2.0	Power Factor: 0.448

Harm#	Harmonics V-rms	Limit V-rms	% of Limit	Status
2	0.127	0.460	27.67	OK
3	0.640	2.069	30.95	OK
4	0.057	0.460	12.42	OK
5	0.127	0.920	13.84	OK
6	0.025	0.460	5.52	OK
7	0.030	0.690	4.42	OK
8	0.018	0.460	3.86	OK
9	0.035	0.460	7.51	OK
10	0.019	0.460	4.23	OK
11	0.016	0.230	7.02	OK
12	0.014	0.230	6.02	OK
13	0.017	0.230	7.31	OK
14	0.008	0.230	3.38	OK
15	0.011	0.230	4.86	OK
16	0.011	0.230	4.85	OK
17	0.009	0.230	3.73	OK
18	0.012	0.230	5.21	OK
19	0.009	0.230	3.86	OK
20	0.016	0.230	7.08	OK
21	0.007	0.230	3.11	OK
22	0.014	0.230	5.92	OK
23	0.008	0.230	3.38	OK
24	0.006	0.230	2.40	OK
25	0.006	0.230	2.70	OK
26	0.009	0.230	3.72	OK
27	0.005	0.230	2.35	OK
28	0.006	0.230	2.80	OK
29	0.006	0.230	2.80	OK
30	0.005	0.230	2.30	OK
31	0.004	0.230	1.59	OK
32	0.005	0.230	2.07	OK
33	0.006	0.230	2.57	OK
34	0.002	0.230	1.05	OK
35	0.004	0.230	1.53	OK
36	0.003	0.230	1.20	OK
37	0.005	0.230	2.04	OK
38	0.003	0.230	1.21	OK
39	0.003	0.230	1.18	OK
40	0.006	0.230	2.57	OK

4.5 VOLTAGE CHANGES, VOLTAGE FLUCTUATIONS AND FLICKER TEST

4.5.1 LIMITS

Tests	Limits	Descriptions
	EN 61000-3-3	
Pst	≤ 1.0 , $T_p= 10$ min.	Short Term Flicker Indicator
Plt	≤ 0.65 , $T_p=2$ hr.	Long Term Flicker Indicator
dc	$\leq 3.3\%$	Relative Steady-State V-Chang
dmax	$\leq 4\%$	Maximum Relative V-change
d (t)	$\leq 3.3\%$ for > 500 ms	Relative V-change characteristic

4.5.2 MEASUREMENT INSTRUMENTS LIST

Item	Kind of Equipment	Manufacturer	Type No.	Serial No.	Calibrated until
1	Harmonics and Flicker Analyzer	California Instruments	PACS-1	72344	Jul. 26, 2017
2	3KVA AC Power source	California Instruments	3001ix	56309	Jul. 26, 2017
3	Measurement Software	California	CTS4.0 Version 4.9	N/A	N/A

Remark: "N/A" denotes no model name, no serial No. or no calibration specified.

All calibration period of equipment list is one year.

4.5.3 TEST PROCEDURE

- a. Tests was performed according to the Test Conditions/Assessment of Voltage Fluctuations specified in EN 61000-3-3 depend on which standard adopted for compliance measurement.
- b. All types of harmonic current and/or voltage fluctuation in this report are assessed by direct measurement using flicker-meter.

4.5.4 DEVIATION FROM TEST STANDARD

No deviation

4.5.5 TESTSETUP

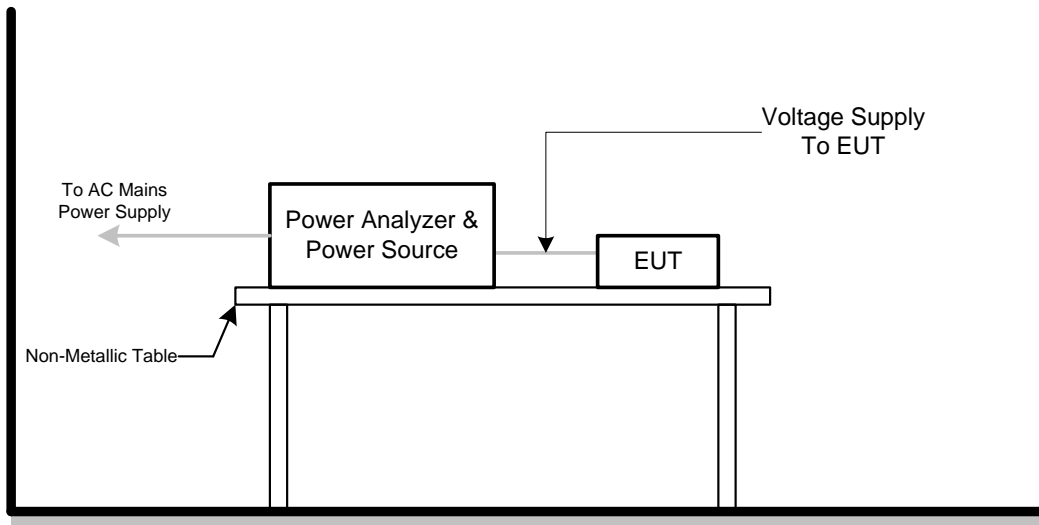

4.5.6 TEST RESULTS

EUT	IP Phone	Model Name	F4G
Temperature	25°C	Relative Humidity	55%
Test Voltage	AC 230V/50Hz		
Test Mode	Adapter Supply:Handfree		

Psti and limit line

European Limits

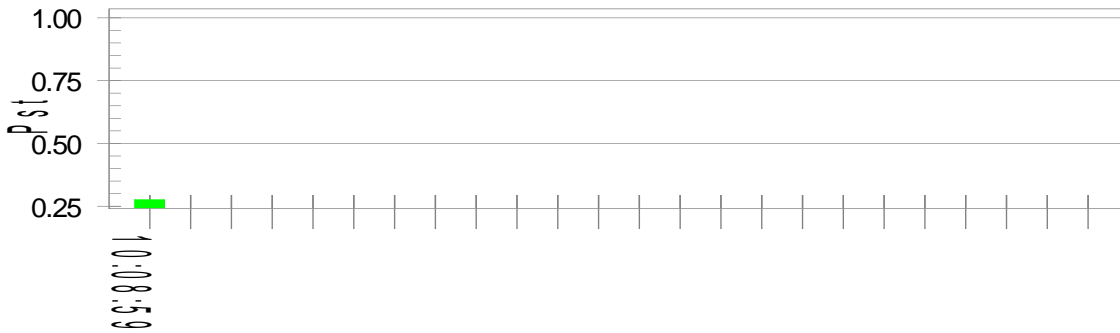

Plt and limit line

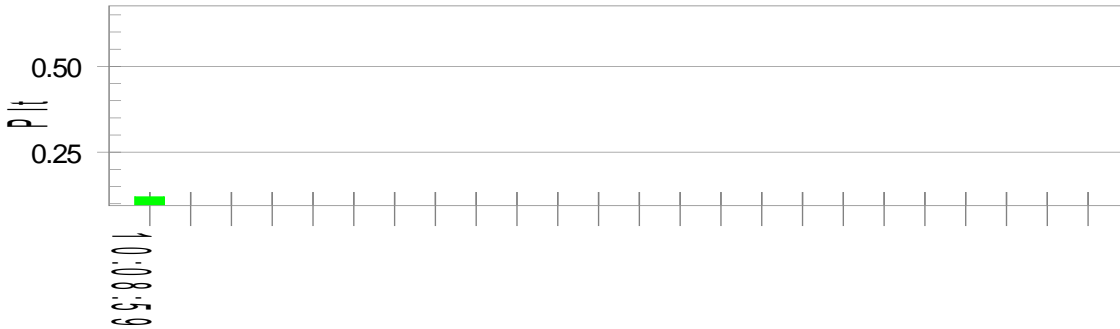

Parameter values recorded during the test:

Vrms at the end of test (Volt):229.92

Highest dt (%):	0.00	Test limit (%):	N/A	N/A
T-max (mS):	0	Test limit (mS):	500.0	Pass
Highest dc (%):	0.00	Test limit (%):	3.30	Pass
Highest dmax (%):	-0.06	Test limit (%):	4.00	Pass
Highest Pst (10 min. period):	0.277	Test limit:	1.000	Pass
Highest Plt (2 hr. period):	0.121	Test limit:	0.650	Pass

5. EMC IMMUNITY TEST

5.1 STANDARD COMPLIANCE/SEVERITY LEVEL/CRITERIA

Tests Standard No.	Test Specification Level / Test Mode	Test Ports	Criteria
Electrostatic discharge EN 61000-4-2 (ESD)	±8 kV air discharge ±4 kV contact discharge (Direct Mode)	Enclosure	B
	±4kV HCP discharge ±4kV VCP discharge (Indirect Mode)	Enclosure	B
Radiated, radio-frequency, electromagnetic field immunity EN 61000-4-3 (RS)	80 MHz to 1000 MHz 3V/m(unmodulated, r.m.s), 1 kHz, 80%, AM modulated	Enclosure	A
Electrical fast transient/burst immunity EN 61000-4-4 (EFT/Burst)	±0.5kV(peak) 5/50ns Tr/Th 5kHz Repetition Frequency (100kHz Repetition Frequency for xDSL equipment)	Signal ports and telecommunication ports (Only applicable to cable length>3 m)	B
	±0.5kV(peak) 5/50ns Tr/Th 5kHz Repetition Frequency	DC Power Ports	B
	±1 kV(peak) 5/50ns Tr/Th 5kHz Repetition Frequency	AC Power Ports	B
Surge immunity EN 61000-4-5 (Surges)	±1 kV(peak) 10/700 Tr/Th μs(NOTE) (without primary protection)	Signal ports and telecommunication ports (applicable only to ports connect directly to outdoor cables)	C
	±4 kV(peak) 10/700 Tr/Th μs(NOTE) (with primary protectors fitted)		C
	±0.5 kV(peak) 1.2/50(8/20) Tr/Th μs	DC Power Ports (applicable only to ports connect directly to outdoor cables)	B
	±1 kV(peak) 1.2/50(8/20) Tr/Th μs (line to line)	AC Power Ports	B
	±2 kV(peak) 1.2/50(8/20) Tr/Th μs (line to earth or ground)		B

Immunity to conducted disturbances, induced by radio-frequency fields EN 61000-4-6 (Injected Current)	0.15 MHz to 80 MHz 3V(unmodulated, r.m.s), 1kHz 80%, AM 150Ω source impedance	Signal ports and telecommunication ports (Only applicable to cable length>3 m)	A
	0.15 MHz to 80 MHz 3V(unmodulated, r.m.s), 1kHz 80%, AM 150Ω source impedance	DC Power Ports	A
	0.15 MHz to 80 MHz 3V(unmodulated, r.m.s), 1kHz 80%, AM 150Ω source impedance	AC Power Ports	A
Power frequency magnetic field immunity EN 61000-4-8 (PFMF)	50 Hz or 60Hz, 1A/m(r.m.s) μs	Enclosure	A
Voltage dips, short interruptions and voltage variations immunity EN 61000-4-11 (Voltage Interruption/Dips)	Voltage reduction > 95% 0.5 period Voltage reduction 30% 25 periods Voltage reduction > 95% 250 periods	AC Power Ports	B C C

Note.

Where the coupling network for the 10/700 μs waveform affects the functioning of high speed data ports, the test shall be carried out using a 1,2/50 (8/20) μs waveform and appropriate coupling network.

5.2 GENERAL PERFORMANCE CRITERIA

According to **EN55024** standard, the general performance criteria as following:

<p>Criterion A</p>	<p>The equipment shall continue to operate as intended without operator intervention. No degradation of performance or loss of function is allowed below a performance level specified by the manufacturer when the equipment is used as intended. The performance level may be replaced by a permissible loss of performance.</p> <p>If the minimum performance level or the permissible performance loss is not specified by the manufacturer, then either of these may be derived from the product description and documentation, and by what the user product description and documentation, and by what the user may reasonably expect from the equipment if used as intended.</p>
<p>Criterion B</p>	<p>After the test, the equipment shall continue to operate as intended without operator intervention. No degradation of performance or loss of function is allowed, after the application of the phenomenon below a performance level specified by the manufacturer, when the equipment is used as intended. The performance level may be replaced by a permissible loss of performance.</p> <p>During the test, degradation of performance is allowed. However, no change of operating state if stored data allowed to persist after the test. If the minimum performance level (or the permissible performance loss) is not specified by the manufacturer, then either of these may be derived from the product description and documentation, and by what the user may reasonably expect from the equipment if used as intended.</p>
<p>Criterion C</p>	<p>Loss of function is allowed, provided the function is self-recoverable, or can be restored by the operation of the controls by the user in accordance with the manufacturer's instructions.</p> <p>Functions, and/or information stored in non-volatile memory, or protected by a battery backup, shall not be lost.</p>

5.3 ELECTROSTATIC DISCHARGE IMMUNITY TEST (ESD)

5.3.1 TEST SPECIFICATION

Basic Standard	EN 61000-4-2
Discharge Impedance	330 ohm / 150 pF
Required Performance	B
Discharge Voltage	Air Discharge: ± 2 kV, ± 4 kV, ± 8 kV (Direct) Contact Discharge: ± 2 kV, ± 4 kV (Direct/Indirect)
Polarity	Positive & Negative
Number of Discharge	Air Discharge: min. 20 times at each test point Contact Discharge: min. 200 times in total
Discharge Mode	Single Discharge
Discharge Period	1 second minimum

5.3.2 MEASUREMENT INSTRUMENTS

Item	Kind of Equipment	Manufacturer	Type No.	Serial No.	Calibrated until
1	ESD Generator	TESEQ AG	NSG 437	450	Nov. 03, 2017

Remark: "N/A" denotes no model name, no serial No. or no calibration specified.

All calibration period of equipment list is one year.

5.3.3 TEST PROCEDURE

The test generator necessary to perform direct and indirect application of discharges to the EUT in the following manner:

- a. Contact discharge was applied to conductive surfaces (Direct) and coupling planes (Indirect) of the EUT.

During the test, it was performed with single discharges. For the single discharge time between successive single discharges was at least 1 second. The EUT shall be exposed to at least 200 discharges, 100 each at negative and positive polarity, at a minimum of four test points. One of the test points shall be subjected to at least 50 indirect discharges to the center of the front edge of the horizontal coupling plane. The remaining three test points shall each receive at least 50 direct contact discharges.

If no direct contact test points are available, then at least 200 indirect discharges shall be applied in the indirect mode. Test shall be performed at a maximum repetition rate of one discharge per second.

Vertical Coupling Plane (VCP):

The coupling plane, of dimensions 0.5m x 0.5m, is placed parallel to, and positioned at a distance 0.1m from, the EUT, with the Discharge Electrode touching the coupling plane.

The four faces of the EUT will be performed with electrostatic discharge.

Horizontal Coupling Plane (HCP):

The coupling plane is placed under to the EUT. The generator shall be positioned vertically at a distance of 0.1m from the EUT, with the Discharge Electrode touching the coupling plane.

The four faces of the EUT will be performed with electrostatic discharge.

- b. Air discharges at insulation surfaces of the EUT.

It was at least ten single discharges with positive and negative at the same selected point.

5.3.4 DEVIATION FROM TEST STANDARD

No deviation

5.3.5 TEST SETUP

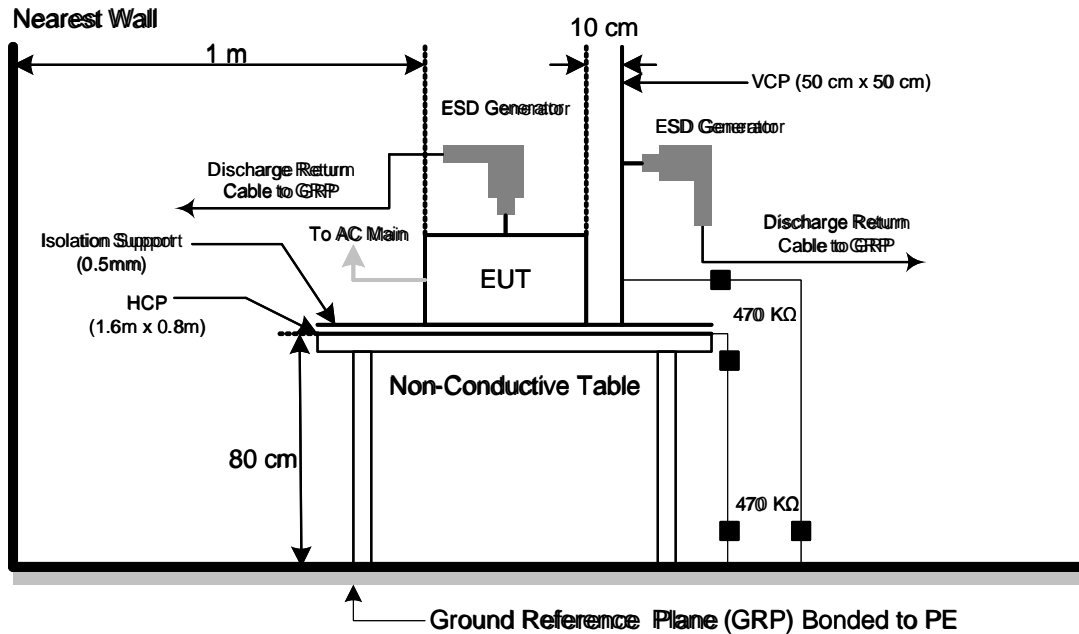

Note:

TABLE-TOP EQUIPMENT

The configuration consisted of a wooden table 0.8 meters high standing on the Ground Reference Plane. The GRP consisted of a sheet of aluminum at least 0.25mm thick, and 2.5 meters square connected to the protective grounding system. A Horizontal Coupling Plane (1.6m x 0.8m) was placed on the table and attached to the GRP by means of a cable with 940k total impedance. The equipment under test was installed in a representative system as described in EN 61000-4-2, and its cables were placed on the HCP and isolated by an insulating support of 0.5mm thickness. A distance of 1-meter minimum was provided between the EUT and the walls of the laboratory and any other metallic structure.

FLOOR-STANDING EQUIPMENT

The equipment under test was installed in a representative system as described in EN 61000-4-2, and its cables were isolated from the Ground Reference Plane by an insulating support of 0.1-meter thickness. The GRP consisted of a sheet of aluminum that is at least 0.25mm thick, and 2.5meters square connected to the protective grounding system and extended at least 0.5 meters from the EUT on all sides.

5.3.6 TEST RESULTS

EUT	IP Phone	Model Name	F4G
Temperature	25°C	Relative Humidity	
Test Voltage	AC 230V/50Hz, PoE 48V	Pressure	1010hPa
Test Mode	Adapter Supply:Handfree,Adapter Supply:Handset,Adapter Supply:Earphone,PoE Supply:Handfree,PoE Supply:Handset,PoE Supply:Earphone		

Mode	Air Discharge								Contact Discharge						
	2kV		4kV		8kV		- kV		2kV		4kV		- kV		
Location	P	N	P	N	P	N	P	N	P	N	P	N	P	N	
1	A	A	A	A	A	A	-	-	-	-	-	-	-	-	
2	A	A	A	A	A	A	-	-	-	-	-	-	-	-	
3	A	A	A	A	A	A	-	-	-	-	-	-	-	-	
4	A	A	A	A	A	A	-	-	-	-	-	-	-	-	
5	A	A	A	A	A	A	-	-	-	-	-	-	-	-	
6	A	A	A	A	A	A	-	-	-	-	-	-	-	-	
7	A	A	A	A	A	A	-	-	-	-	-	-	-	-	
8	A	A	A	A	A	A	-	-	-	-	-	-	-	-	
Criteria	B								-		B				-
Result	A								-		-				-
Judgment	PASS								-		-				-

Mode	HCP Contact Discharge						VCP Contact Discharge						
	2kV		4kV		- kV		2kV		4kV		- kV		
Location	P	N	P	N	P	N	P	N	P	N	P	N	
1	A	A	A	A	-	-	A	A	A	A	-	-	
2	A	A	A	A	-	-	A	A	A	A	-	-	
3	A	A	A	A	-	-	A	A	A	A	-	-	
4	A	A	A	A	-	-	A	A	A	A	-	-	
Criteria	B						-		B				-
Result	A						-		A				-
Judgment	PASS						-		PASS				-

Note:

- 1) P/N denotes the Positive/Negative polarity of the output voltage.
- 2) Test condition:
 Direct/Indirect(HCP/VCP) discharges: Minimum 50 times (Positive/Negative) at eachpoint.
 Air discharges: Minimum 20 times (Positive/Negative) at each point.
- 3) Test location(s) in which discharge (Air and contact discharge) to be applied illustrated by photos shown in next page(s)
- 4) The Indirect (HCP/VCP) discharges description of test point as following:
 1.left side: 2.right side: 3.front side: 4.rear side.
- 5) N/A - denotes test is not applicable in this test report
- 6) Criterion A: No observation of any performance degradation.
- 7) Criterion B: Some degradation of performance is observed but the equipment continues to operate as intended.
- 8) Criterion C: Loss of functionality, but self-recoverable by user, without loss of information or settings.

PHOTO(S) SHOWN THE LOCATION(S) OF ESD EVALUATED



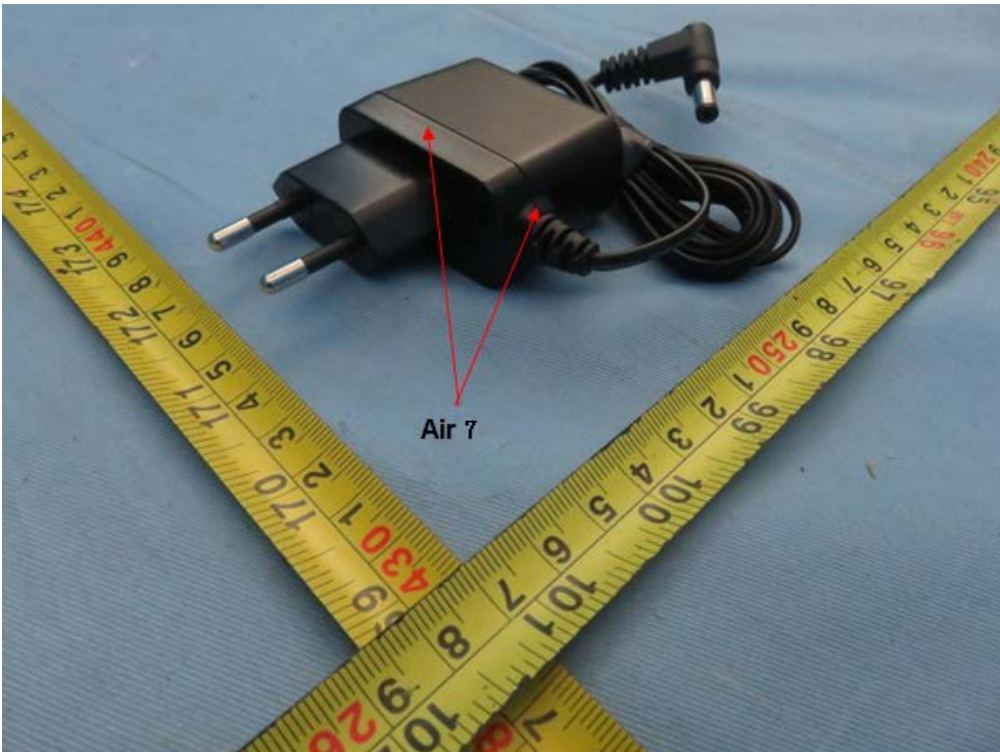
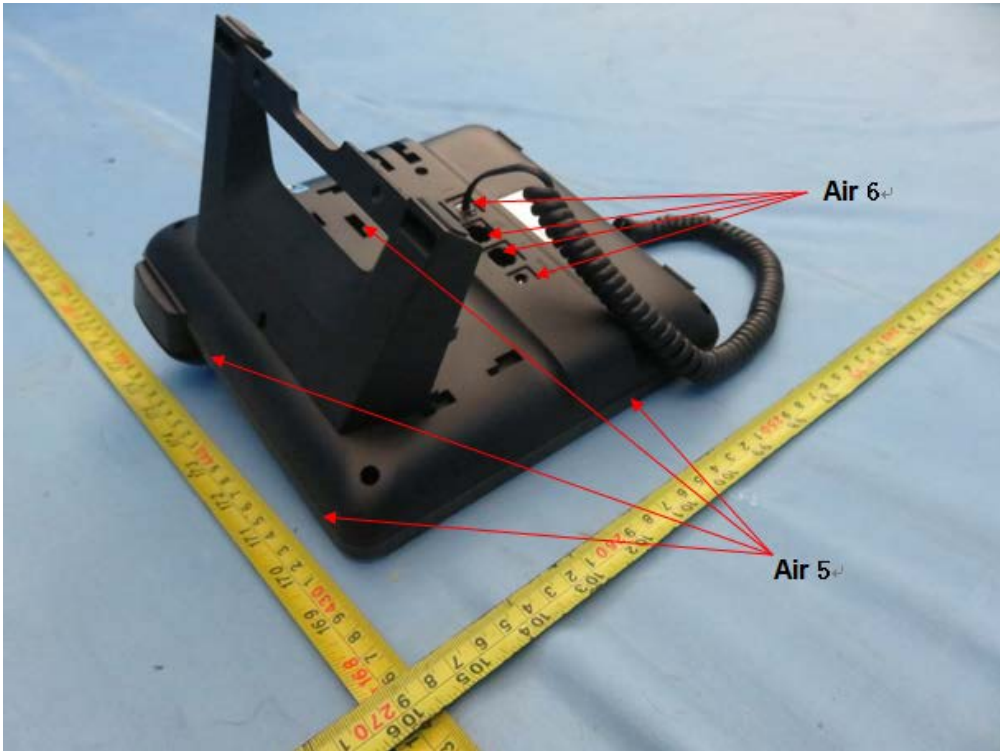

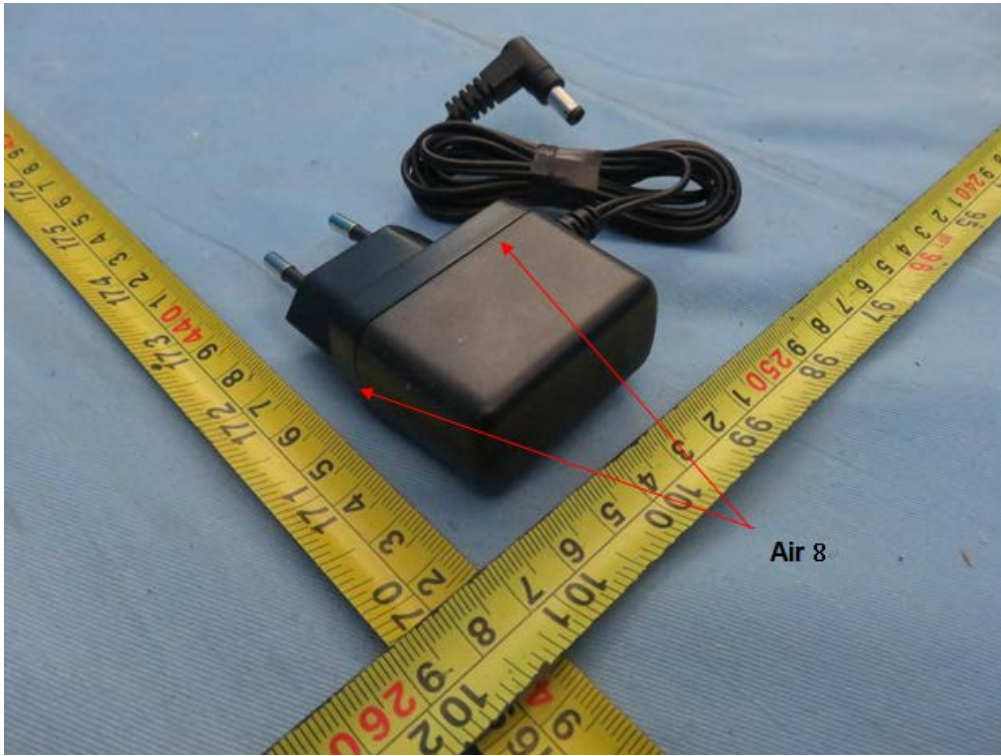

5.4 RADIATED, RADIO-FREQUENCY, ELECTROMAGNETIC FIELD IMMUNITY TEST (RS)

5.4.1 TEST SPECIFICATION

Basic Standard	EN 61000-4-3
Required Performance	A
Frequency Range	80 MHz - 1000 MHz
Field Strength	3 V/m(unmodulated, r.m.s)
Modulation	1 kHz Sine Wave, 80%, AM Modulation
Frequency Step	1% of fundamental
Polarity of Antenna	Horizontal and Vertical
Test Distance	3 m
Antenna Height	1.5 m
Dwell Time	at least 3 seconds

5.4.2 MEASUREMENT INSTRUMENTS

Item	Kind of Equipment	Manufacturer	Type No.	Serial No.	Calibrated until
1	Antenna	ETS	3142C	47662	Mar. 27, 2017
2	Digital Signal Generator	HP	ESG-D300 0A	US36260188	Mar. 27, 2017
3	Power amplifier	MILMEGA	80RF1000- 250	1064833	Nov. 02, 2017
4	Measurement Software	TOYO	IM5/R Ver 3.8.050	N/A	N/A

Remark: "N/A" denotes no model name, no serial No. or no calibration specified.
All calibration period of equipment list is one year.

5.4.3 TEST PROCEDURE

The EUT and support equipment, which are placed on a table that is 0.8 meter above ground and the testing was performed in a fully-anechoic chamber.

The testing distance from antenna to the EUT was 3 meters.

The other condition as following manner:

- a. The field strength level was 3 V/m(unmodulated, r.m.s).
- b. The frequency range is swept from 80 MHz to 1000 MHz, with the signal 80%amplitude modulated with a 1 kHz sine wave. The rate of sweep did not exceed 1.5×10^{-3} decade/s. Where the frequency range is swept incrementally, the step size was 1% of fundamental.
- c. The dwell time at each frequency shall be not less than the time necessary for the EUT to be able to respond.
- d. The test was performed with the EUT exposed to both vertically and horizontally polarized fields on each of the four sides.

5.4.4 DEVIATION FROM TEST STANDARD

No deviation

5.4.5 TEST SETUP

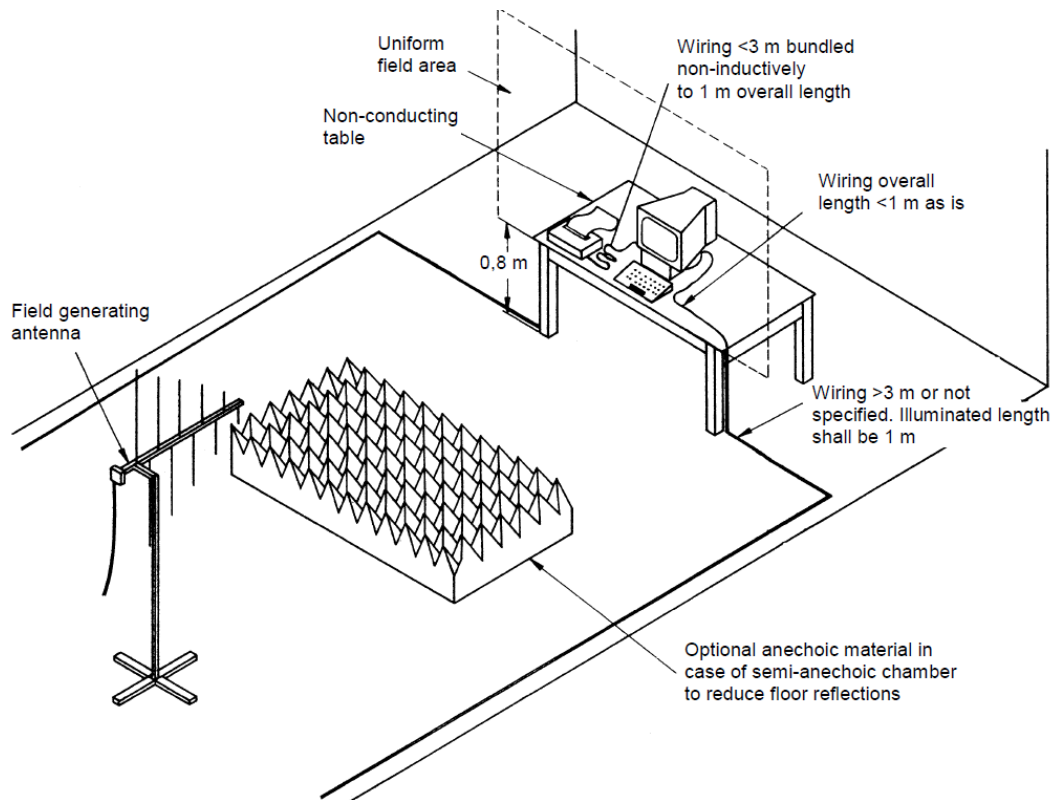

Note:

TABLE-TOP EQUIPMENT

The EUT installed in a representative system as described in EN 61000-4-3 was placed on a non-conductive table 0.8 meters in height. The system under test was connected to the power and signal wire according to relevant installation instructions.

FLOOR-STANDING EQUIPMENT

The EUT installed in a representative system as described in EN 61000-4-3 was placed on a non-conductive wood support 0.1 meters in height. The system under test was connected to the power and signal wire according to relevant installation instructions.

5.4.6 TEST RESULTS

EUT	IP Phone	Model Name	F4G
Temperature	25°C	Relative Humidity	
Test Voltage	AC 230V/50Hz, PoE 48V		
Test Mode	Adapter Supply:Handfree,Adapter Supply:Handset,Adapter Supply:Earphone,PoE Supply:Handfree,PoE Supply:Handset,PoE Supply:Earphone		

Frequency Range (MHz)	RF Field Position	R.F. Field Strength	Azimuth	Criterion	Result	Judgment
80 - 1000	H / V	3V (unmodulated, r.m.s) AM Modulated 1000Hz, 80%	0	A	A	PASS
			90			
			180			
			270			

Note:

- 1) P/N denotes the Positive/Negative polarity of the output voltage.
- 2) N/A - denotes test is not applicable in this test report.
- 3) Criterion A: No observation of any performance degradation.
- 4) Criterion B: Some degradation of performance is observed but the equipment continues to operate as intended.
- 5) Criterion C: Loss of functionality, but self-recoverable by user, without loss of information or settings.

5.5 ELECTRICAL FAST TRANSIENT/BURST IMMUNITY TEST (EFT/BURST)

5.5.1 TEST SPECIFICATION

Basic Standard	EN 61000-4-4
Required Performance	B
Test Voltage	Power Line: ± 0.5 kV, ± 1 kV Signal/Control Line: ± 0.5 kV
Polarity	Positive & Negative
Impulse Frequency	5 kHz: except for xDSL equipment 100 kHz: only for single lines of xDSL equipment.
Impulse Wave shape	5/50 ns
Burst Duration	15 ms
Burst Period	300 ms
Test Duration	Not less than 1 min.

5.5.2 MEASUREMENT INSTRUMENTS

Item	Kind of Equipment	Manufacturer	Type No.	Serial No.	Calibrated until
1	Capacitor Clamp	Thermo KeyTek	CCL	0502215	Mar. 27, 2017
2	THE MODULAR SOLUTION FOR 6 KV APPLICATIONS	Teseq	NSG 3060	1423	Sep. 04, 2017
3	Measurement Software	Teseq	Win 3000 Version 1.2.0	N/A	N/A

Remark: "N/A" denotes no model name, no serial No. or no calibration specified.

All calibration period of equipment list is one year.

5.5.3 TEST PROCEDURE

The EUT and support equipment(s) are placed on a table that is 0.8 meter high above a metal ground plane and should be located 0.1 m \pm 0.01m high above the Ground Reference Plane (1m*1m min. and 0.65mm thick min).

The other condition as following manner:

- The length of power cord between the coupling device and the EUT should not exceed 1 meter.
- Both positive and negative polarity discharges were applied.
- The duration time of each test sequential was 1 minute

5.5.4 DEVIATION FROM TEST STANDARD

No deviation

5.5.5 TEST SETUP

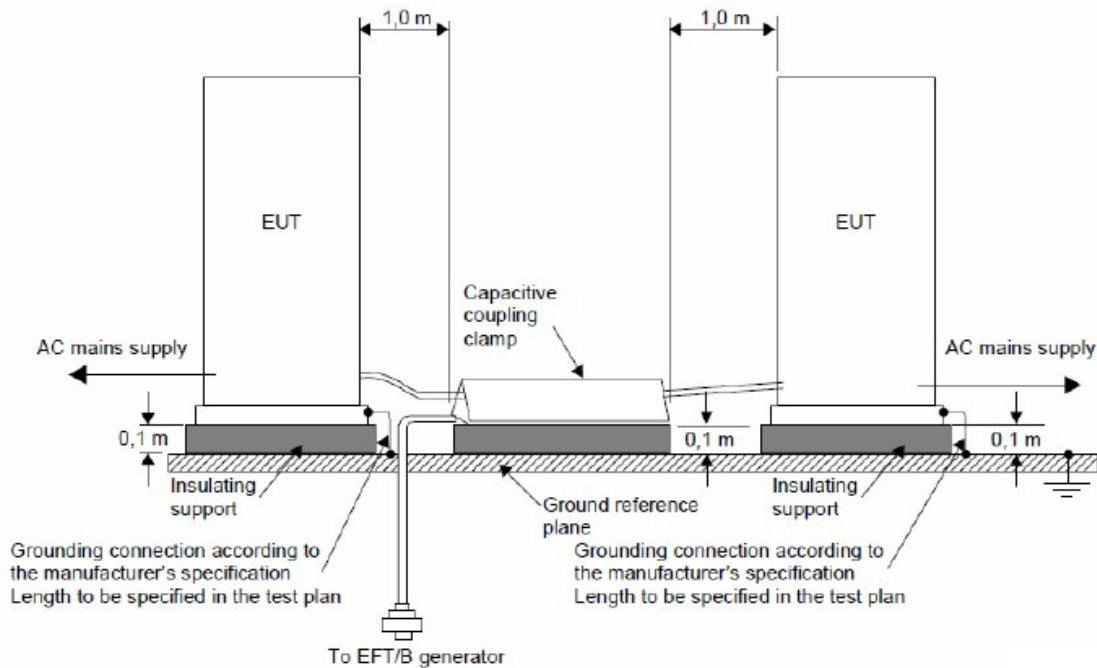
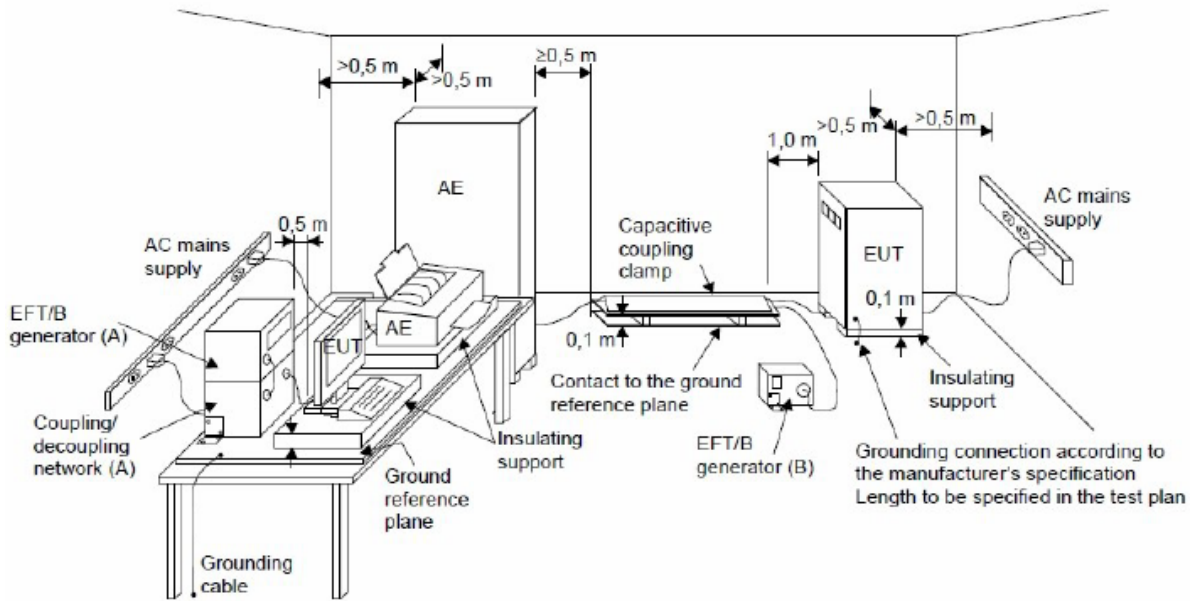

Note:

TABLE-TOP EQUIPMENT

The configuration consisted of a wooden table (0.8m high) standing on the Ground Reference Plane and should be located 0.1 m+/- 0.01m above the Ground Reference Plane. The GRP consisted of a sheet of aluminum (at least 0.25mm thick and 2.5m square) connected to the protective grounding system. A minimum distance of 0.5m was provided between the EUT and the walls of the laboratory or any other metallic structure.

FLOOR-STANDING EQUIPMENT

The EUT installed in a representative system as described in EN 61000-4-4 and its cables were isolated from the Ground Reference Plane by an insulating support that is 0.1-meter thick. The GRP consisted of a sheet of aluminum (at least 0.25mm thick and 2.5m square) connected to the protective grounding system.

5.5.6 TEST RESULTS

EUT	IP Phone	Model Name	F4G
Temperature	25°C	Relative Humidity	
Test Voltage	AC 230V/50Hz, PoE 48V		
Test Mode	Adapter Supply:Handfree,Adapter Supply:Handset,Adapter Supply:Earphone,PoE Supply:Handfree,PoE Supply:Handset,PoE Supply:Earphone		

EUT Ports Tested		Polarity	Repetition Frequency	Test Level 1kV	Criterion	Result	Judgment
AC Power Port	Line (L)	+	5 kHz	A	B	A	PASS
		-	5 kHz	A			
	Neutral (N)	+	5 kHz	A	B	A	PASS
		-	5 kHz	A			
	Ground (PE)	+	5 kHz	-	B	-	PASS
		-	5 kHz	-			

EUT Ports Tested		Polarity	Repetition Frequency	Test Level 0.5 kV	Criterion	Result	Judgment
Signal/Data/ Control Port	WAN	+	5 kHz	A	B	A	PASS
		-	5 kHz	A			
Signal/Data/ Control Port	LAN	+	5 kHz	A	B	A	PASS
		-	5 kHz	A			

Note:

- 1) P/N denotes the Positive/Negative polarity of the output voltage.
- 2) N/A - denotes test is not applicable in this test report
- 3) Criterion A: No observation of any performance degradation.
- 4) Criterion B: Some degradation of performance is observed but the equipment continues to operate as intended.
- 5) Criterion C: Loss of functionality, but self-recoverable by user, without loss of information or settings.

5.6 SURGE IMMUNITY TEST

5.6.1 TEST SPECIFICATION

Basic Standard	EN 61000-4-5
Required Performance	B
Wave-Shape	Combination Wave for power lines 1.2/50 us Open Circuit Voltage 8 /20 us Short Circuit Current
Test Voltage	Power Line: ± 0.5 kV, ± 1 kV, ± 2 kV
Surge Input/Output	L-N, L-PE, N-PE
Generator Source Impedance	2 ohm between networks 12 ohm between network and ground
Polarity	Positive/Negative
Phase Angle:	AC Port: $0^\circ/90^\circ/180^\circ/270^\circ$
Pulse Repetition Rate	1 time / min. (maximum)
Number of Tests	5 positive and 5 negative at selected points

5.6.2 MEASUREMENT INSTRUMENTS

Item	Kind of Equipment	Manufacturer	Type No.	Serial No.	Calibrated until
3	THE MODULAR SOLUTION FOR 6 KV APPLICATIONS	Teseq	NSG 3060	1423	Sep. 04, 2017
4	Measurement Software	Teseq	Win 3000 Version 1.2.0	N/A	N/A

Remark: "N/A" denotes no model name, no serial No. or no calibration specified.
All calibration period of equipment list is one year.

5.6.3 TEST PROCEDURE

a. For EUT power supply:

The surge is to be applied to the EUT power supply terminals via the capacitive coupling network. Decoupling networks are required in order to avoid possible adverse effects on equipment not under test that may be powered by the same lines, and to provide sufficient decoupling impedance to the surge wave. The power cord between the EUT and the coupling/decoupling networks shall be 2meters in length (or shorter).

b. For test applied to unshielded unsymmetrically operated interconnection lines of EUT :

The surge is applied to the lines via the capacitive coupling. The coupling /decoupling networks shall not influence the specified functional conditions of the EUT. The interconnection line between the EUT and the coupling/decoupling networks shall be 2 meters in length (or shorter).

c. For test applied to unshielded symmetrically operated interconnection /telecommunication lines of EUT :

The surge is applied to the lines via gas arrestors coupling. Test levels below the ignition point of the coupling arrestor cannot be specified. The interconnection line between the EUT and the coupling/decoupling networks shall be 2 meters in length (or shorter).

5.6.4 DEVIATION FROM TEST STANDARD

No deviation

5.6.5 TEST SETUP

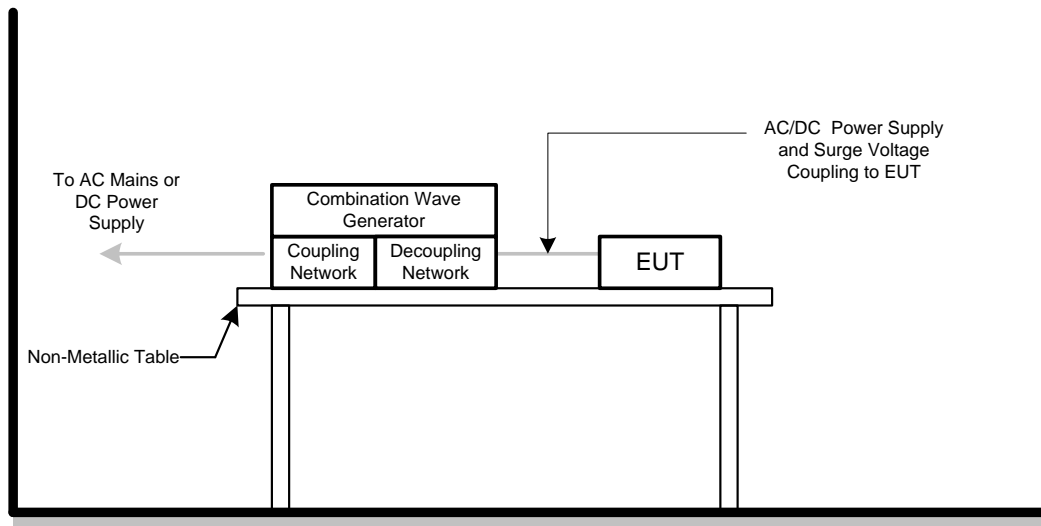

5.6.6 TEST RESULTS

EUT	IP Phone	Model Name	F4G
Temperature	25°C	Relative Humidity	
Test Voltage	AC 230V/50Hz, PoE 48V		
Test Mode	Adapter Supply:Handfree,Adapter Supply:Handset,Adapter Supply:Earphone,PoE Supply:Handfree,PoE Supply:Handset,PoE Supply:Earphone		

Wave Form	EUT Ports Tested	1.2/50(8/20)Tr/Thµs						Criterion	Result	Judgment
		Polarity	Phase	Voltage						
				0.5kV	1kV	-- kV	-- kV			
AC	L – N (2 ohm)	+/-	0°	A	A	-	-	B	A	PASS
		+/-	90°	A	A	-	-			
		+/-	180°	A	A	-	-			
		+/-	270°	A	A	-	-			

Note:

- 1) Polarity and Numbers of Impulses: 5 Pst / Ngt at each tested mode
- 2) N/A - denotes test is not applicable in this Test Report
- 3) Criterion A: No observation of any performance degradation.
- 4) Criterion B: Some degradation of performance is observed but the equipment continues to operate as intended.
- 5) Criterion C: Loss of functionality, but self-recoverable by user, without loss of information or settings.

5.7 IMMUNITY TO CONDUCTED DISTURBANCES, INDUCED BY RADIO-FREQUENCY FIELDS TEST (CS)

5.7.1 TEST SPECIFICATION

Basic Standard	EN 61000-4-6
Required Performance	A
Frequency Range	0.15 MHz - 80 MHz
Field Strength	3 V (unmodulated, r.m.s.)
Modulation	1 kHz Sine Wave, 80%, AM Modulation
Frequency Step	1% of fundamental
Dwell Time	at least 3 seconds

5.7.2 MEASUREMENT INSTRUMENTS

Item	Kind of Equipment	Manufacturer	Type No.	Serial No.	Calibrated until
1	Signal Generator	HP	8648A	3636A02964	Mar. 27, 2017
2	Power Amplifier	Teseq	CBA230M-080	T43748	Mar. 27, 2017
3	Power CDN	FCC	FCC-801-M2/M3-16A	100271	Mar. 27, 2017
4	Signal Line CDN	FCC	F-090407-1004-1	100518	Mar. 27, 2017
5	Measurement Software	TOYO	IM5/C Ver 3.7.028	N/A	N/A

Remark: "N/A" denotes no model name, no serial No. or no calibration specified.

All calibration period of equipment list is one year.

5.7.3 TEST PROCEDURE

The EUT and support equipment, are placed on a table that is 0.8 meter above a metal ground plane measured 1m*1m min. and 0.65mm thick min.

The other condition as following manner:

- a. The field strength level was 3 V (unmodulated, r.m.s.)
- b. The frequency range is swept from 150 kHz to 80 MHz, with the signal 80%amplitude modulated with a 1 kHz sine wave. The rate of sweep did not exceed 1.5×10^{-3} decade/s. Where the frequency range is swept incrementally, the step size was 1% of fundamental.
- c. The dwell time at each frequency shall be not less than the time necessary for the EUT to be able to respond.

5.7.4 DEVIATION FROM TEST STANDARD

No deviation

5.7.5 TEST SETUP

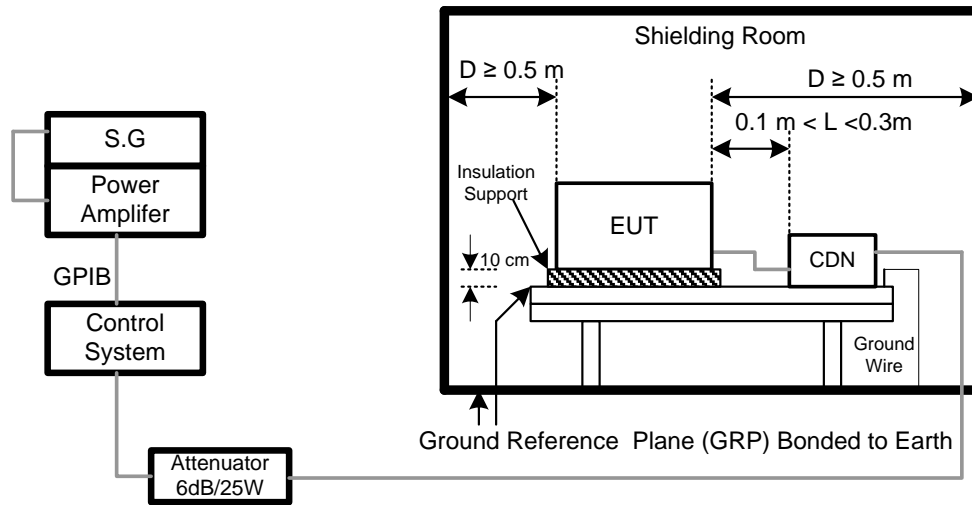

NOTE:

FLOOR-STANDING EQUIPMENT

The equipment to be tested is placed on an insulating support of 0.1 meters height above a ground reference plane. All relevant cables shall be provided with the appropriate coupling and decoupling devices at a distance between 0.1 meters and 0.3 meters from the projected geometry of the EUT on the ground reference plane.

5.7.6 TEST RESULTS

EUT	IP Phone	Model Name	F4G
Temperature	25°C	Relative Humidity	
Test Voltage	AC 230V/50Hz, PoE 48V		
Test Mode	Adapter Supply:Handfree,Adapter Supply:Handset,Adapter Supply:Earphone,PoE Supply:Handfree,PoE Supply:Handset,PoE Supply:Earphone		

Test Ports (Mode)	Freq.Range (MHz)	Field Strength	Criteria	Results	Judgment
Input/ Output AC.PowerPort	0.15 ---80	3V(unmodulated, r.m.s) AM Modulated 1000Hz, 80%	A	A	PASS
Input/ Output DC. PowerPort	0.15 --- 80		A	N/A	N/A
Signal Line (WAN)	0.15 --- 80		A	A	PASS
Signal Line (LAN)	0.15 --- 80		A	A	PASS

Note:

- 1). N/A - denotes test is not applicable in this test report.
- 2) Criterion A: No observation of any performance degradation.
- 3) Criterion B: Some degradation of performance is observed but the equipment continues to operate as intended.
- 4) Criterion C: Loss of functionality, but self-recoverable by user, without loss of information or settings.

5.8 POWER FREQUENCY MAGNETIC FIELD IMMUNITY TEST (PFMF)

5.8.1 TEST SPECIFICATION

Basic Standard	EN 61000-4-8
Required Performance	A
Frequency Range	50/60 Hz
Field Strength	1 A/m
Observation Time	1 minute
Inductance Coil	Rectangular type, 1mx1m

5.8.2 MEASUREMENT INSTRUMENTS

Item	Kind of Equipment	Manufacturer	Type No.	Serial No.	Calibrated until
1	Magnetic Field test Generator	FCC	F-1000-4-8-G-125A	04032	Mar. 27, 2017
2	Magnetic Field immunity loop	Thermo KeyTek	F-1000-4-8/9/10-L-1M	04024	Mar. 27, 2017

Remark: "N/A" denotes no model name, no serial No. or no calibration specified.
All calibration period of equipment list is one year.

5.8.3 TEST PROCEDURE

The EUT and support equipment, are placed on a table that is 0.8 meter above a metal ground plane measured 1m*1m min. and 0.65mm thick min.

The other condition as following manner:

- a. The equipment cabinets shall be connected to the safety earth directly on the GRP via the earth terminal of the EUT.
- b. The cables supplied or recommended by the equipment manufacturer shall be used. 1 meter of all cables used shall be exposed to the magnetic field.

5.8.4 DEVIATION FROM TEST STANDARD

No deviation

5.8.5 TEST SETUP

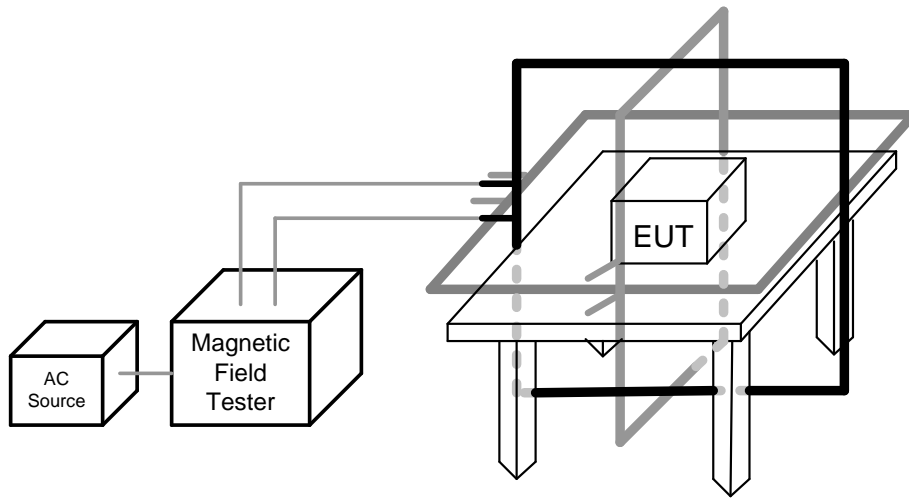

Note:

TABLE-TOP EQUIPMENT

The equipment shall be subjected to the test magnetic field by using the induction coil of standard dimension (1 m x 1 m). The induction coil shall then be rotated by 90 degrees in order to expose the EUT to the test field with different orientations.

FLOOR-STANDING EQUIPMENT

The equipment shall be subjected to the test magnetic field by using induction coils of suitable dimensions. The test shall be repeated by moving and shifting the induction coils, in order to test the whole volume of the EUT for each orthogonal direction. The test shall be repeated with the coil shifted to different positions along the side of the EUT, in steps corresponding to 50 percent of the shortest side of the coil. The induction coil shall then be rotated by 90 degrees in order to expose the EUT to the test field with different orientations.

5.8.6 TEST RESULTS

EUT	IP Phone	Model Name	F4G
Temperature	25°C	Relative Humidity	
Test Voltage	AC 230V/50Hz, PoE 48V		
Test Mode	Adapter Supply:Handfree,Adapter Supply:Handset,Adapter Supply:Earphone,PoE Supply:Handfree,PoE Supply:Handset,PoE Supply:Earphone		

50Hz

Test Mode	Test Level	Antenna aspect	Duration (s)	Criteria	Results	Judgment
Enclosure	1 A/m	X	60	A	A	PASS
Enclosure	1 A/m	Y	60	A	A	PASS
Enclosure	1 A/m	Z	60	A	A	PASS

60Hz

Test Mode	Test Level	Antenna aspect	Duration (s)	Criteria	Results	Judgment
Enclosure	1 A/m	X	60	A	A	PASS
Enclosure	1 A/m	Y	60	A	A	PASS
Enclosure	1 A/m	Z	60	A	A	PASS

Note:

- 1). N/A - denotes test is not applicable in this test report.
- 2) Criterion A: No observation of any performance degradation.
- 3) Criterion B: Some degradation of performance is observed but the equipment continues to operate as intended.
- 4) Criterion C: Loss of functionality, but self-recoverable by user, without loss of information or settings.

5.9 VOLTAGE DIPS, SHORT INTERRUPTIONS AND VOLTAGE VARIATIONS IMMUNITY TEST

5.9.1 TEST SPECIFICATION

Basic Standard	EN 61000-4-11
Required Performance	B (For >95% Voltage Dips) C (For 30% Voltage Dips) C (For >95% Voltage Interruptions)
Test Duration Time	Minimum three test events in sequence
Interval between Event	Minimum ten seconds
Phase Angle	0°/180°
Test Cycle	3 times

5.9.2 MEASUREMENT INSTRUMENTS

Item	Kind of Equipment	Manufacturer	Type No.	Serial No.	Calibrated until
1	THE MODULAR SOLUTION FOR 6 KV APPLICATIONS	Teseq	NSG 3060	1423	Sep. 04, 2017
2	Measurement Software	Teseq	Win 3000 Version 1.2.0	N/A	N/A

Remark: "N/A" denotes no model name, no serial No. or no calibration specified.

All calibration period of equipment list is one year.

5.9.3 TEST PROCEDURE

The EUT shall be tested for each selected combination of test levels and duration with a sequence of three dips/interruptions with intervals of 10 s minimum (between each test event). Each representative mode of operation shall be tested. Abrupt changes in supply voltage shall occur at zero crossings of the voltage waveform.

5.9.4 DEVIATION FROM TEST STANDARD

No deviation

5.9.5 TEST SETUP

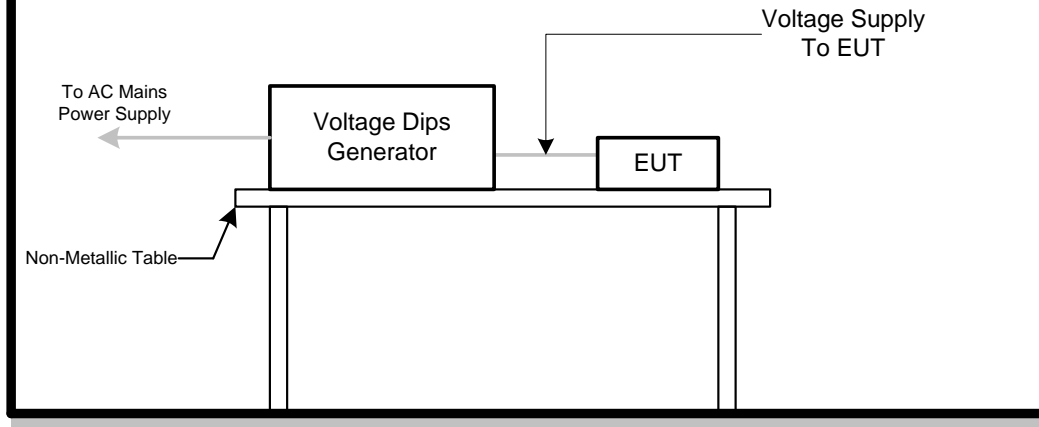

5.9.6 TEST RESULTS

EUT	IP Phone	Model Name	F4G
Temperature	25°C	Relative Humidity	
Test Voltage	AC 230V/50Hz, PoE 48V		
Test Mode	Adapter Supply:Handfree,Adapter Supply:Handset,Adapter Supply:Earphone,PoE Supply:Handfree,PoE Supply:Handset,PoE Supply:Earphone		

AC 100V/50Hz				
VoltageReduction	Periods	Criteria	Results	Judgment
Voltage dip > 95%	0.5	B	A	PASS
Voltage dip 30%	25	C	C	PASS
Interruption > 95%	250	C	C	PASS

AC 230V/50Hz				
VoltageReduction	Periods	Criteria	Results	Judgment
Voltage dip > 95%	0.5	B	A	PASS
Voltage dip 30%	25	C	A	PASS
Interruption > 95%	250	C	C	PASS

AC 240V/50Hz				
VoltageReduction	Periods	Criteria	Results	Judgment
Voltage dip > 95%	0.5	B	A	PASS
Voltage dip 30%	25	C	A	PASS
Interruption > 95%	250	C	C	PASS

Note:

- 1). N/A - denotes test is not applicable in this test report.
- 2) Criterion A: No observation of any performance degradation.
- 3) Criterion B: Some degradation of performance is observed but the equipment continues to operate as intended.
- 4) Criterion C: Loss of functionality, but self-recoverable by user, without loss of information or settings.