



Specification For Approval

承认书

Customer Name 客户名称: 方位通讯

Type of product 产品: AC ADAPTER

Product No.产品编号: SG01104

Model No.型号: NBS12E120100VE (Y=100PF)

Customer P/N 客户编号:

Input 输入:100-240Vac, 50/60Hz, 0.3A

Output 输出: 12.0V, 1.0A

Sample No.样品编号: M1501104

REV 版本:1.0

Unit Color 颜色: White Black

Approval Signature / 客户签名

Company Chop 公司签章

Approval / 承认

Check / 检验

Test / 测试

Environmental Protection Requirements / 环保要求

REACH PAHs PHTHALATE(3P) PHTHALATE(6P) PHTHALATE(7P)
 PHTHALATE(16P) CPSIA CP65(3P) CP65(5P) NP Other _____

Note: The basic requirement for products is RoHS, please take a tick before your other requirements.

Manufacture Signature / 制造商签名

Sales / 业务

QA / 品管

Engineer / 设计

Sample / 制样

袁秋华

高水瑛

王磊

路宝安

Shenzhen Mass Power Electronic Limited 深圳市迈思普电子有限公司

Add:437#, Hedong Village, Hengkeng Community, Guanlan Street,

Bao'an District, Shenzhen City

地址: 深圳市宝安区观澜镇横坑河东村 437 号 (环观中路)

Tel: 86-755-33075917

Fax: 86-755-27621302



Record of Revision 变更履历

Item	REV.	Reason	Detail	Date
1	1.0	/	First Edition	2015-07-03



1	ROHS DECLARATION	5
2	ELECTRICAL SPECIFICATION	6
2.1	INPUT REQUIREMENTS	6
2.2	OUTPUT REQUIREMENTS	6
2.2.1	<i>Output Voltage and Current</i>	6
2.2.2	<i>Ripple & Noise</i>	6
2.2.3	<i>average Efficiency</i>	6
2.2.4	<i>Line Regulation</i>	6
2.2.5	<i>Load Regulation</i>	6
2.2.6	<i>Turn On Delay Time</i>	6
2.2.7	<i>Rise Time</i>	6
2.2.8	<i>Hold UP Time</i>	7
2.2.9	<i>OverShoot and undershoot</i>	7
2.2.10	<i>Dynamic response</i>	7
2.3	PROTECTION CHARACTERISTICS	7
2.3.1	<i>Over current protection</i>	7
2.3.2	<i>Over voltage protection</i>	7
2.3.3	<i>Short circuit protection</i>	7
2.4	ENVIRONMENTAL CONDITION	7
2.4.1	<i>Temperature</i>	7
2.4.2	<i>Humidity</i>	7
2.4.3	<i>Altitude</i>	7
2.4.4	<i>Vibration</i>	7
2.5	SAFETY STANDARDS	8
2.6	ELECTROMAGNETIC COMPATIBILITY	8
2.6.1	<i>Electrostatic discharge immunity</i>	8
2.6.2	<i>Radiation electromagnetic immunity</i>	8
2.6.3	<i>fast transient immunity</i>	8
2.6.4	<i>Surge immunity</i>	8
2.6.5	<i>Conducted disturbances immunity</i>	9
2.6.6	<i>Voltage Dips, Interruption & Variations</i>	9
2.6.7	<i>Conducted emissions</i>	9
2.6.8	<i>Radiated emissions</i>	9
2.6.9	<i>FCC</i>	9
2.6.10	<i>C-Tick</i>	9
2.7	RELIABILITY	9
2.7.1	<i>Burn-in</i>	9
2.7.2	<i>Mean Time Between Failure (MTBF)</i>	9
2.8	ADDITIONAL REQUIREMENT	9
2.8.1	<i>Leakage Current</i>	9
2.8.2	<i>Dielectric Withstand Voltage (Hi-Pot)</i>	10
2.8.3	<i>Insulation Resistance</i>	10
2.8.4	<i>Drop</i>	10
3	CIRCUIT SCHEMATIC	10
4	PCB LAYOUT	11
5	MECHANICAL	12



5.1	ENCLOSURE DRAWING	12
5.2	LABEL DRAWING	13
5.3	DC CABLE & PLUG	14
6	PACKING INFORMATION	15

1 RoHS Declaration



深圳市迈思普电子有限公司

Declaration of EU RoHS 2.0 Conformity (欧盟 RoHS 2.0 符合性声明)

We Shenzhen Mass Power Electronic Limited, Ltd here by declare that our products indicated below were in full conformity with EU Directive 2011/65/EU, with respect to the following substances:

我公司, 深圳市迈思普电子有限公司在此声明:

我公司生产的以下产品中各项有害物质的含量完全符合欧盟指令 2011/65/EU:

- 1) Lead(Pb)铅<1000ppm
- 2) Mercury(Hg)汞<1000ppm
- 3) Cadmium(Cd)镉<100ppm
- 4) Hexavalent chromium(Cr6+)六价铬<1000ppm
- 5) Polybrominated biphenyls(PBB) 多溴联苯<1000ppm
- 6) Polybrominated diphenylethers (PBDE) 多溴二苯醚<1000ppm

Company Name and Stamp / 公司名称及盖章:

Signature / 公司负责人签名:



Date / 日期: 2015.01.27

2 Electrical Specification

2.1 Input Requirements

Item	Minimum	Nominal	Maximum	Unit	Remark
Rated Input Voltage	100	115/230	240	Vac	
Input Voltage Range	90	---	264	Vac	
Rated Frequency	---	50/60	---	Hz	
Frequency Range	47	---	63	Hz	
Input Current	---	---	0.3	A	at 100Vac/60Hz-240Vac/50Hz
Input Inrush Current	---	---	60	A	Cool Start 230Vac
Power Consumption	---	---	0.1	W	No Load, 115Vac & 230Vac

2.2 Output Requirements

2.2.1 OUTPUT VOLTAGE AND CURRENT

Rated Output Voltage (DC)	Voltage Range(V)	No load (A)	Min load (A)	Max load (A)	Rated Output Power (W)	Note
12.0	11.4-12.6	0	0	1.0	12.0	

The power supply output voltage must stay within the limits specified in table 2 when operating at steady state.

2.2.2 RIPPLE & NOISE

Ripple and Noise are tested by dc loading side parallel with a 47uF/EC and 0.1uF/Ceramic Capacitors and measured Band-Width with DC-20MHz and the result must less than 100mV.

2.2.3 AVERAGE EFFICIENCY

The average efficiency is larger than 82.96% which is at 115Vac/60Hz and 230Vac/50Hz with 100%, 75%, 50% and 25% rated load. This result comply with the efficiency level VI of Energy Star Standard "Version 2.0".

2.2.4 LINE REGULATION

The line regulation of rated output voltage is less than $\pm 5\%$, while measuring at rated load and +/-10% of input voltage changing.

2.2.5 LOAD REGULATION

The load regulation of rated output voltage is less than $\pm 5\%$, at measured output load from 10% to 100% rated load .

2.2.6 TURN ON DELAY TIME

At nominal input AC voltage and full load, it must larger than 3000mS.

2.2.7 RISE TIME

The Supply shall have a start-up rise time of less than 30mS within regulation limits for all DC outputs.

2.2.8 HOLD UP TIME

At nominal input AC voltage and full load, it must larger than 10mS.

2.2.9 OVERSHOOT AND UNDERSHOOT

The output voltage over/undershoot upon the application or removal of the input voltage, under the input conditions specified in Section 2.1, shall be less than $\pm 10\%$ above the nominal voltage. No voltage of opposite polarity shall be present on output during turn-on or turn-off.

2.2.10 DYNAMIC RESPONSE

The output voltage must between 11.4V to 12.6V when the output load is from 20% to 80% and than back to 20% with a 0.15A/ μ sec slew rate.

2.3 Protection Characteristics

2.3.1 OVER CURRENT PROTECTION

The output shall be protected against the over current conditions. A power cycle shall be required to restore normal operation. The min output current is less than 3.0A at 230Vac.

2.3.2 OVER VOLTAGE PROTECTION

The output voltage shall be clamped by internal protection zener.

2.3.3 SHORT CIRCUIT PROTECTION

The power supply shall have self-limiting protection. This protection can withstand a continuous output short without damaged, and auto-recovery operation after the short is removed.

2.4 Environmental Condition

2.4.1 Temperature

Operating: -0°C to $+40^{\circ}\text{C}$

Storage: -40°C to $+80^{\circ}\text{C}$

2.4.2 HUMIDITY

Operating: 20%to +90%

Storage: 20%to +90%

2.4.3 ALTITUDE

Operating: 5,000ft (Max)

Storage: 20,000ft (Max)

2.4.4 Vibration

The power supply shall be subjected to a vibration test consisting of a 10 to 300Hz sweep at a constant acceleration of 2G for a duration of one 1hour for each of the perpendicular axes X,Y and Z. The power supply shall not incur physical damage or degradation of any characteristics below the performance specifications

2.5 Safety Standards

The power supply shall be certified by following international regulatory standards.

Item	Country	Status	Standard
CE	Europe	Approved	EN60950-1
GS	Germany	---	EN60950-1
UL/cUL	America / Canada	---	UL 60950-1 / CSA C22.2
DOFT	Australia/New Zealand	---	AS/NZS60950-1
CCC	China	---	GB8898
TUV Mark	United Kingdom	---	BS EN60950-1
PSE	Japan	---	J60950
KCC	Korea	---	K60950
CB	Global	--	IEC60950-1

2.6 Electromagnetic Compatibility

2.6.1 ELECTROSTATIC DISCHARGE IMMUNITY

IEC61000-4-2:1995+A1:1998+A2:2000

- Air Discharge: $\pm 8\text{kV}$

- Contact Discharge: $\pm 4\text{kV}$

Discharge Impedance : $330\Omega / 150\text{pF}$

Polarity: Positive and Negative

Performance: Criteria A

2.6.2 RADIATION ELECTROMAGNETIC IMMUNITY

IEC61000-4-3:2002+A1:2002

Range : $80\text{MHz}-1000\text{MHz}$

Field Strength : 3V/m

Distance Antenna-EUT : 3m

Polarity of Antenna : Horizontal and Vertical

Performance: Criteria A

2.6.3 FAST TRANSIENT IMMUNITY

IEC61000-4-4:2004

techniques - Electrical fast transient/burst immunity test

Pulse Amplitude-AC Power Port: 1.0KV

Burst Frequency: 5.0kHz

Polarity of Antenna : Positive and Negative

Performance: Criteria A

2.6.4 SURGE IMMUNITY

IEC61000-4-5:1995+A1:2000

$1.2/50\text{ usec}$ Open Circuit voltage

$8/20\text{ usec}$ Short Circuit current

Power line: 6.0KV

Performance: Criteria A

2.6.5 CONDUCTED DISTURBANCES IMMUNITY

IEC61000-4-6:1996+A1:2000

Range: 0.15MHz-80MHz

Voltage Level: 3V

Step: ≤ 0.015 decades / sec

Performance: Criteria A

2.6.6 VOLTAGE DIPS, INTERRUPTION & VARIATIONS

IEC61000-4-11:1994+A1:2000

100Vac and 240Vac

500mS at 30% of Vnom

10mS $>95\%$ of Vnom

Duration of Interruption($>0.95 \cdot V_{nom}$): 5S

Performance: Criteria B

2.6.7 CONDUCTED EMISSIONS

IEC61000-3-2:2006+A1:2009+A2:2009

Range: 150kHz-30MHz

Margin: <70 dB / QP

<60 dB / AV

2.6.8 RADIATED EMISSIONS

EN61000-3-3:2008

Range: 30MHz-1000MHz

Margin: <40 dB / QP

2.6.9 FCC

FCC Part 15, Class B

2.6.10 C-TICK

CISPR 22

2.7 Reliability

2.7.1 Burn-in

4hours at 40°C ($\pm 5^{\circ}\text{C}$) , Nominal input voltage, 80% of rated load.

2.7.2 Mean Time Between Failure (MTBF)

The power supply shall have a mean time between failures (MTBF) of **50,000** operating hours.

2.8 Additional Requirement

2.8.1 Leakage Current

The power supply leakage current shall be less than 0.25mA.

2.8.2 Dielectric Withstand Voltage (Hi-Pot)

Cut off current: 10mA

Primary to Secondary: 3KVac for 60 Second

2.8.3 Insulation Resistance

Insulation resistance shall be more than 10MΩ at 500Vdc between primary Live, Neutral line and secondary.

2.8.4 DROP

Minimum of one sample shall be dropped from a height of 0.75m onto a 30mm wood board three times 1 cycle. After test, the enclosure cannot be damaged and there are no sharp corner.

3 Circuit Schematic

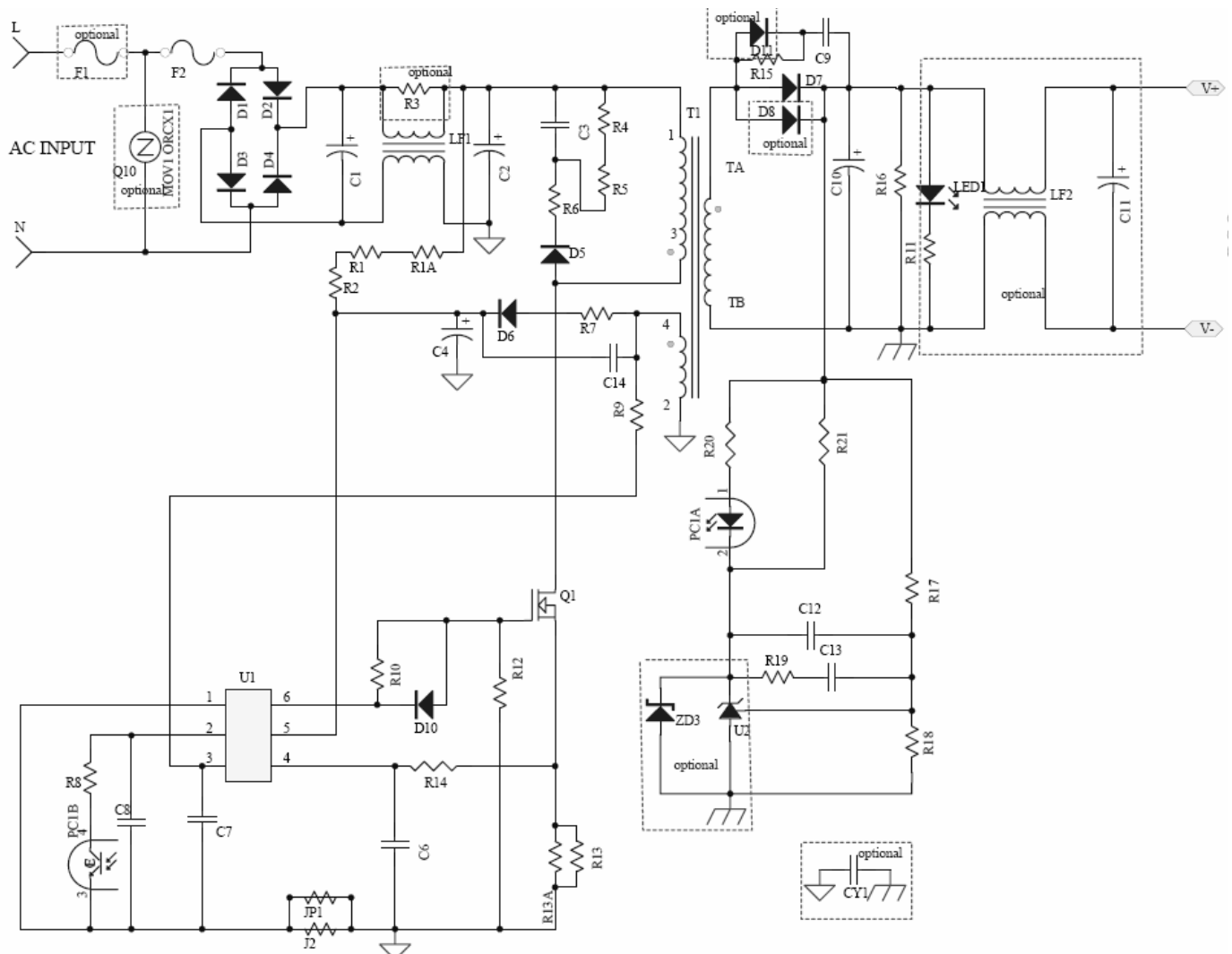

4 PCB Layout

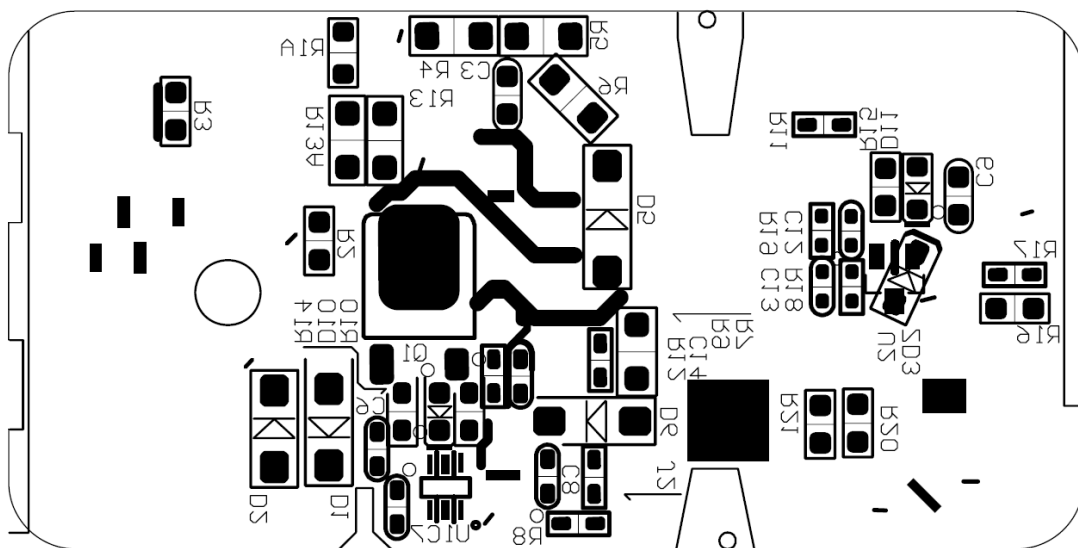
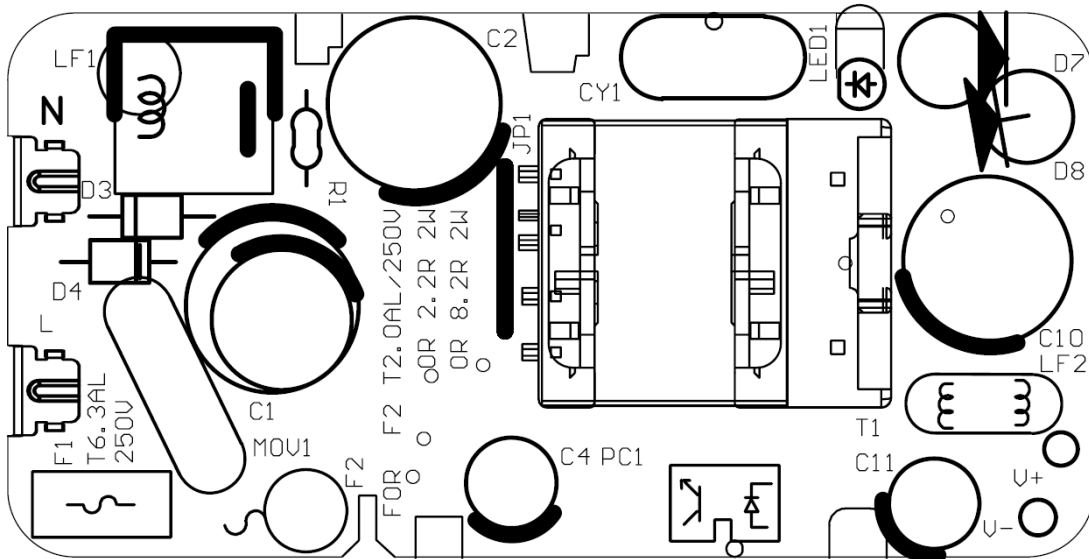
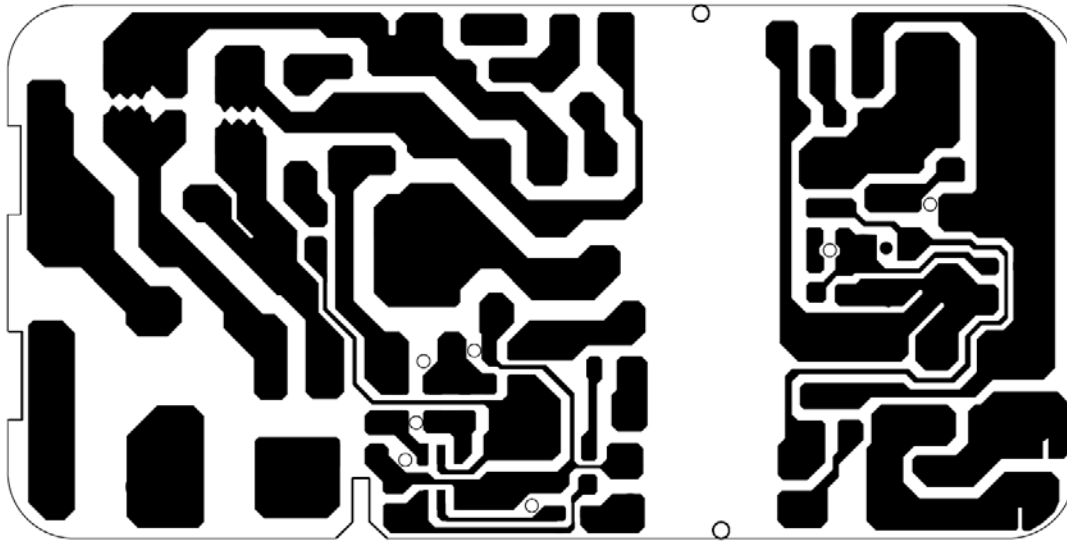

5 Mechanical

5.1 Enclosure drawing

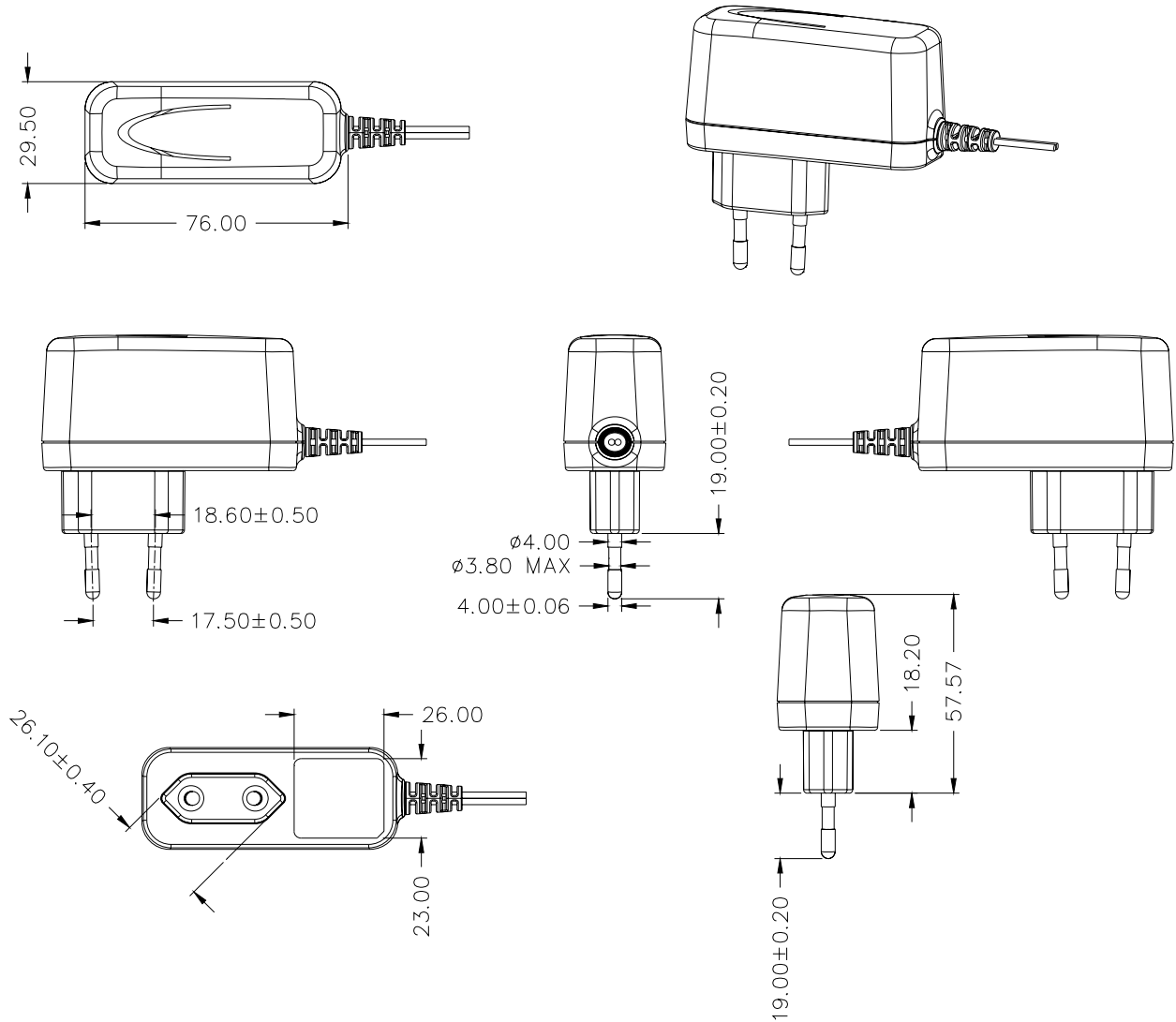

1. Physical size: 76.00±0.5mm(L) * 29.50±0.5mm(W) * 57.57±0.5mm(H)
2. Material: PC, 94V-0
3. Color: Black
4. AC Input Plug: EU
5. Weight: Approx.85.7g

5.2 Label Drawing

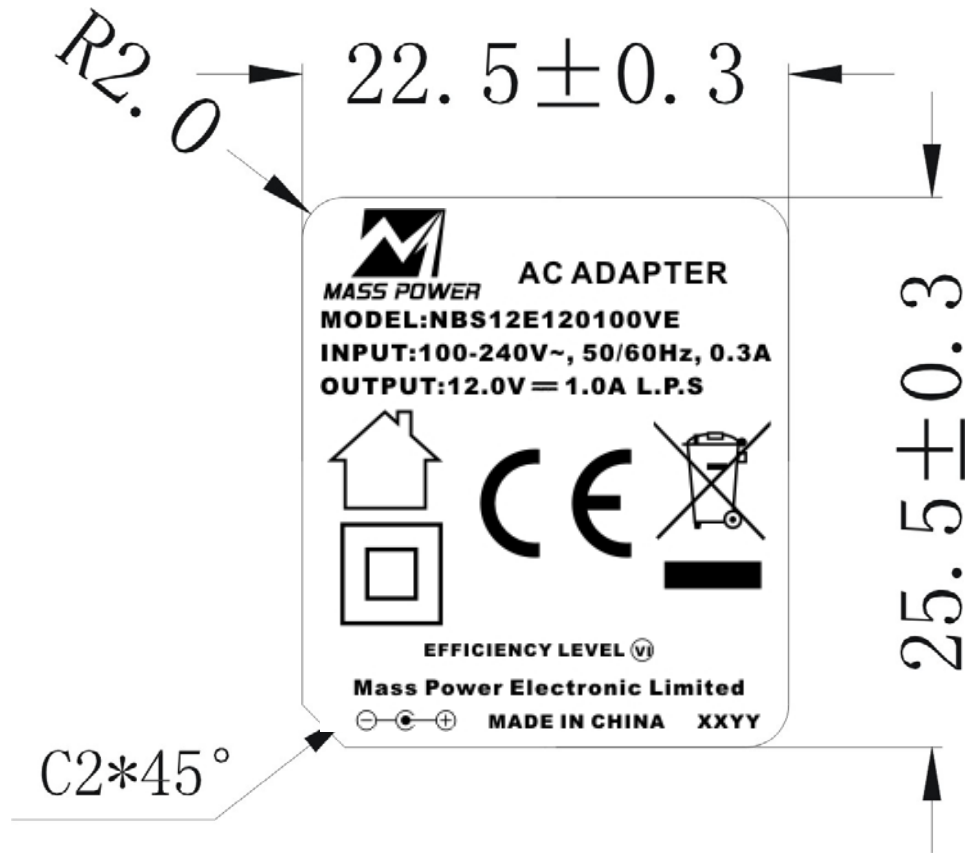

1. Material: Synthetic Paper
2. Thickness : $0.25\text{mm} \pm 0.05\text{mm}$
3. **White** characters, **Black** background

Remark:

The date code will be showed on the nameplate , the number is XXYY。

XX= Year

YY = Month

5.3 DC Cable & Plug

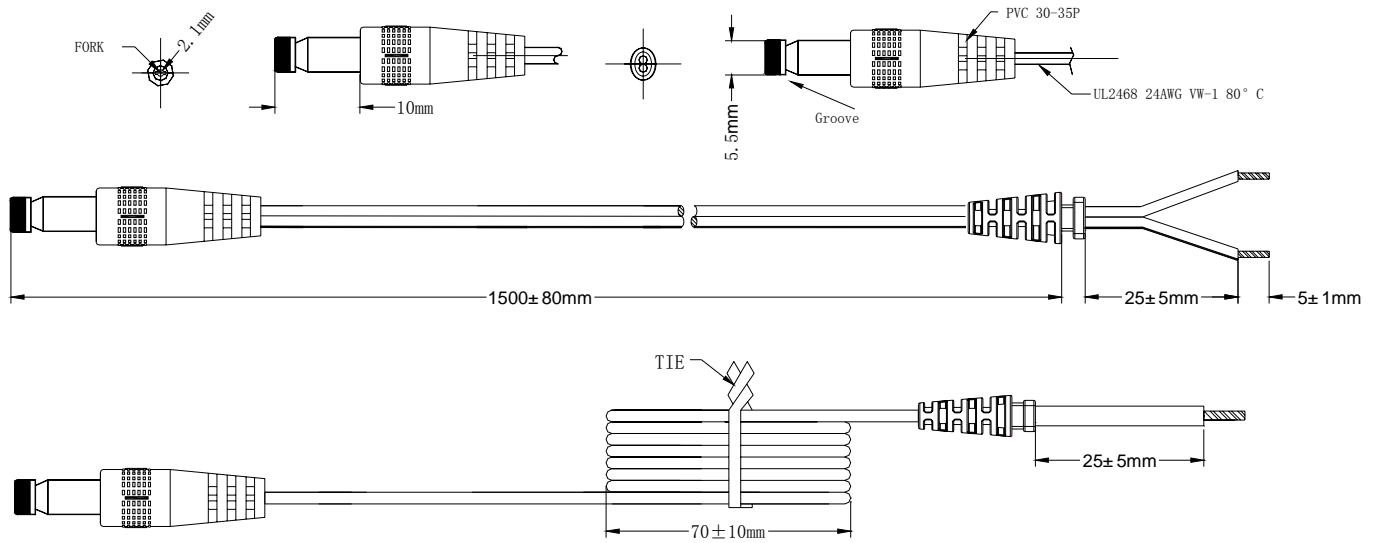

1. DC Plug: 5.5+/-0.05mm * 2.1±0.05mm * 10mm+/-0.5mm Fork & Groove 
2. Wire: UL2468, 300V, 80°C, 24AWG, 1500mm
3. Polarity: BLACK and WHITE ----Positive, BLACK ----Negative
4. DC Jack: PVC

6 Packing Information

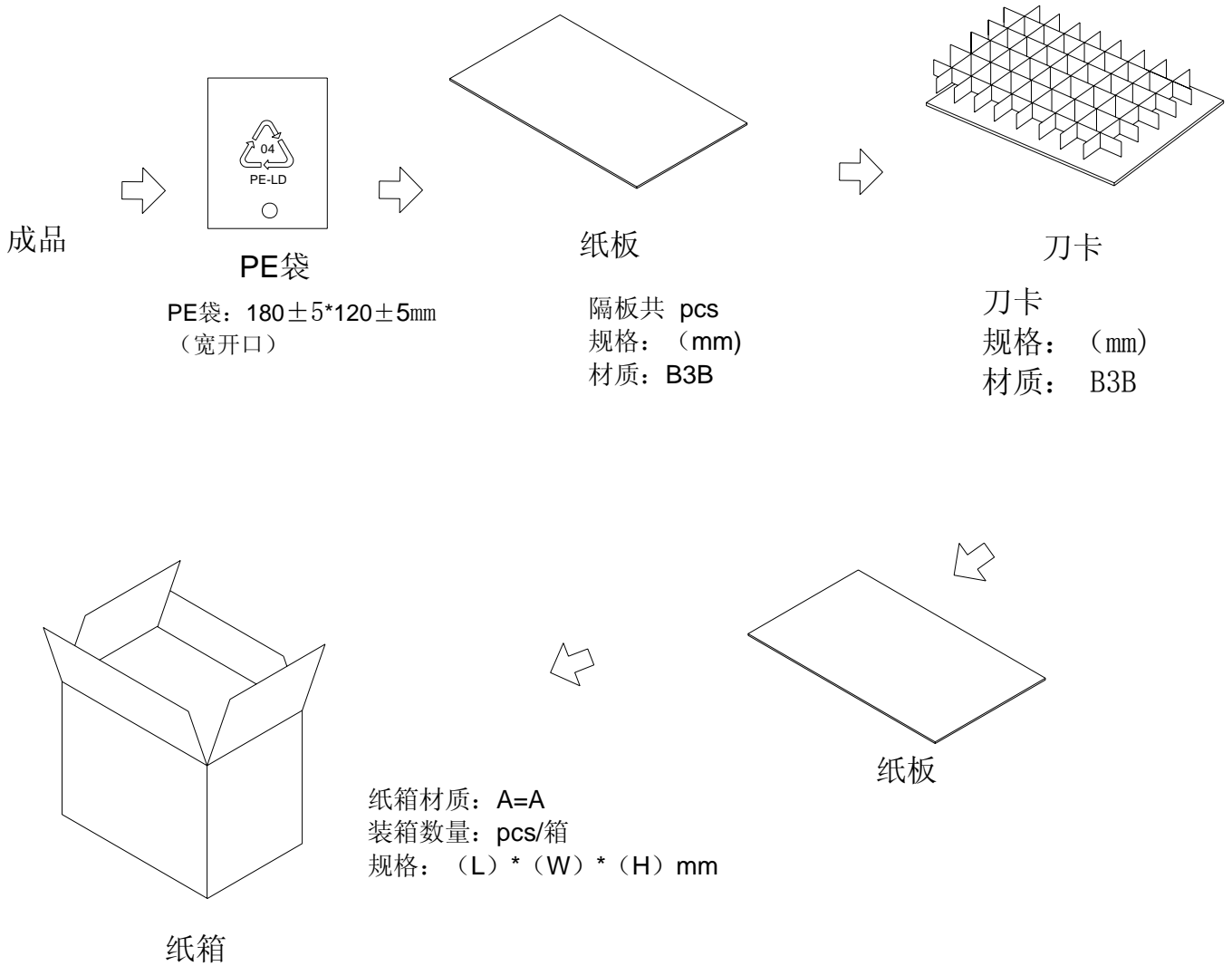



**Shenzhen Mass Power
Electronic Limited**

CUSTOMER: 方位通讯

TYPE OF PRODUCT: AC
ADAPTER

DATE:2015-07-03

PRODUCT NO.:		SG01104		MODEL	NBS12E120100VE		Final judgement:	PASS
CUSTOMER P/N:				REV.:	1.0			
No.	TEST ITEM	TEST CONDITION		SPECIFICATION	RESULT	VERDICT		
1	Input Voltage Range	Input:90Vac-264Vac Output: Min load - Rated load		90~264Vac	OK	PASS		
2	Input Frequency Range	Input: 90Vac-264Vac Output: Min load - Rated load		47~63Hz	OK	PASS		
3	Average Efficiency	Input:230Vac/50Hz 100%,75%,50%,25% load		82.96% (min)	83.97%	PASS		
		Input:115Vac/60Hz 100%,75%,50%,25% load		82.96% (min)	83.47%	PASS		
4	Inrush Current	Input: 230Vac/50Hz Output: Rated load		60A				
5	Input Current	Input: 100Vac/60Hz Output:Rated load		0.6A/rms	0.234	PASS		
		Input: 230Vac/50Hz Output:Rated load		0.6A/rms	0.128	PASS		
		Input: 264Vac/50Hz Output:Rated load		0.6A/rms	0.118	PASS		
6	Line regulation	Input: 90Vac/60Hz	Output: Min load (0.05A)	11.4-12.6V	12.216	PASS		
		Input: 230Vac/50Hz			12.216	PASS		
		Input: 264Vac/50Hz			12.216	PASS		
		Line regulation		5%(max)		PASS		
		Input: 90Vac/50Hz	Output: Rated load	11.4-12.6V	11.906	PASS		
		Input: 230Vac/50Hz			11.904	PASS		
		Input: 264Vac/50Hz			11.906	PASS		
Line Regulation		5%(max)		PASS				
7	Load regulation	Min Load	input:90Vac	11.4-12.6V	12.23	PASS		
		Average Load			12.068	PASS		
		Rated Load			11.906	PASS		
		Load Regulation		5%(max)		PASS		
		Min Load	input:230Vac	11.4-12.6V	12.227	PASS		
		Average Load			12.066	PASS		
		Rated Load			11.904	PASS		
		Load Regulation		5%(max)		PASS		
		Min Load	input:264Vac	11.4-12.6V	12.23	PASS		
		Average Load			12.069	PASS		
		Rated Load			11.906	PASS		
		Load Regulation		5%(max)		PASS		
8	Over Load Ability	Input:100Vac/50Hz		2A(max)	1.51	PASS		
		Input:240Vac/50Hz		2A(max)	1.58	PASS		
9	Short Protection	Input:100Vac/50Hz output: short Output		Input power<5W	0.63	PASS		
		Input:240Vac/50Hz output: short Output		Input power<5W	0.15	PASS		
10	Over Voltage Protection	Input:100Vac/50Hz		/				
		Input:240Vac/50Hz		/				
11	Set up time	Input:100Vac/50Hz Output:rated load		3 S (max)		PASS		
		Input:240Vac/50Hz Output:rated load		3 S (max)		PASS		
12	Hold-up time	Input:240Vac/50Hz Output:rated load		10mS (min)		PASS		
13	Ripple and noise	Input:240Vac50Hz Output: rated load remark:20MHz bandwidth		100mV	54	PASS		
14	Hi-pot	3600Vac /2seconds Primary to Secondary		10mA(max)	OK	PASS		
15	Leakage current	L—FG 90VAC/60Hz		0.25mA	\			
		L—FG 264VAC/50Hz			\			
Tester:	韦红松		Checker:	戴砖		Approver:	杨江贤	

Energy Test

Test Equipment:

NO	Instrument	Manufacturer	Model No
1	AC Source		
2	DC Load	PRODIGIT	3311F
3	Power Meter	YOKOGAWA	WT210

Test Method:

EPA Test Method for Calculating the Energy Efficiency of Single-Voltage External Ac-Dc and Ac-Ac Power Supplies - August 11, 2004

Test Standard:

- Power Supplies, Battery Chargers, and Consumer Audio and Video Equipment 1605
The new energy star version 2.0 specification for external power supplies.
- Minimum Energy Performance Standards (MEPS) AS/NZS4665-2005
- Implementing Directive 2005/32/EC of the European Parliament and of the Council with regard to ecodesign requirements for no-load condition electric power consumption and average active efficiency of external power supplies

Test Condition: 115V 230V 240V

Standards Form:

DC Voltage (V)	DC Current (mA)	Output Power (W)	III	IV	V	VI
12	1000	12.00	71.36%	72.36%	77.76%	82.96%
			No Load (W)	No Load (W)	No Load (W)	No load (W)
			0.75	0.5	0.3	0.1
			CoC Version 5 Tier 1	CoC Version 5 Tier 1 for 10% load	CoC Version 5 Tier2	CoC Version 5 Tier 2 for 10% load
			80.16%	70.16%	83.26%	73.26%
			No load (W)	No load (W)	No Load	No Load
			0.15	NA	0.075	NA

	III	IV	V	VI	CoC Version 5 Tier 1	CoC Version 5 Tier2
CEC	● 2008	● 2008				
Energy Star		● 2007	● 2009			
EUP		● 2010	● 2013			
MEPS	● 2008	● 2009	● 2013			
Kemco	● 2009					
COC Ver 4.0			● 2009			
DoE				● 2013		
CoC Version 5					●2014	●2016

Test Result:

115V					230V					Standard	Conclusion
100%	75%	50%	25%	Average	100%	75%	50%	25%	Average		
81.38%	82.94%	84.51%	85.07%	83.47%	83.84%	83.79%	84.38%	83.89%	83.97%		VI
Consumption Power					Consumption Power						
0.04					0.06					0.1	Pass

Tester:Ye hui jie

Checker:

Approver:

Test Report:

Output Measurements				AC Input Measurements		
100%	Set Output Current to	1000	mA	Measured Input Power	14.63	W
	Measured Output Voltage	11.906	Vdc	True Power Factor	0.627	
	Calculated Output Power	11.906	W	Total Harmonic Distortion (THD)	0.925	
	Calculated Efficiency (Output/Input)				81.38%	
75%	Set Output Current to	750	mA	Measured Input Power	10.84	W
	Measured Output Voltage	11.987	V	True Power Factor	0.607	
	Calculated Output Power	8.990	W	Total Harmonic Distortion (THD)	0.903	
	Calculated Efficiency (Output/Input)				82.94%	
50%	Set Output Current to	500	mA	Measured Input Power	7.14	W
	Measured Output Voltage	12.068	V	True Power Factor	0.581	
	Calculated Output Power	6.034	W	Total Harmonic Distortion (THD)	0.885	
	Calculated Efficiency (Output/Input)				84.51%	
25%	Set Output Current to	250	mA	Measured Input Power	3.57	W
	Measured Output Voltage	12.148	V	True Power Factor	0.548	
	Calculated Output Power	3.037	W	Total Harmonic Distortion (THD)	0.908	
	Calculated Efficiency (Output/Input)				85.07%	
				Average Active Mode Efficiency:	83.47%	
0%	Set the Output to No Load			Measured Input Power	0.04	W
				True Power Factor	0.485	

Power Curve

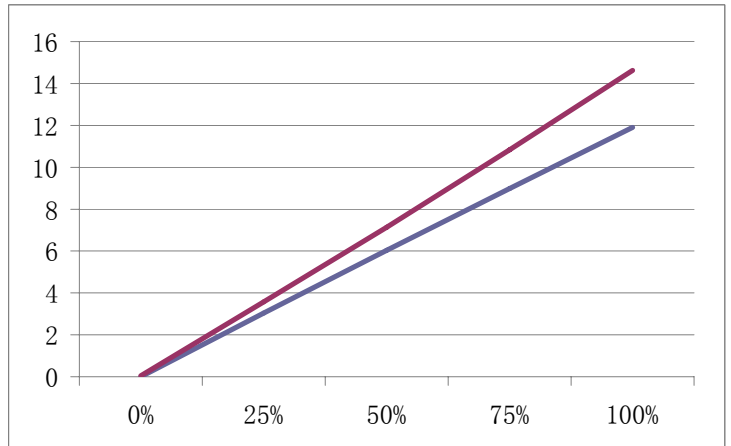
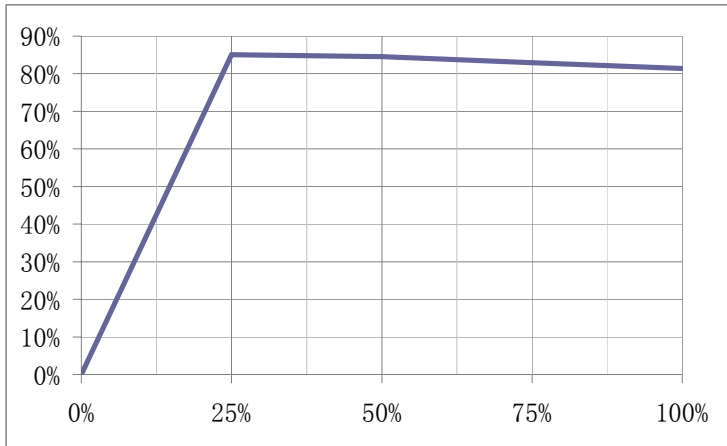

Label:

Test Report:

Output Measurements				AC Input Measurements		
100%	Set Output Current to	1000	mA	Measured Input Power	14.2	W
	Measured Output Voltage	11.905	Vdc	True Power Factor	0.523	
	Calculated Output Power	11.905	W	Total Harmonic Distortion (THD)	0.925	
	Calculated Efficiency (Output/Input)				83.84%	
75%	Set Output Current to	750	mA	Measured Input Power	10.73	W
	Measured Output Voltage	11.987	V	True Power Factor	0.51	
	Calculated Output Power	8.990	W	Total Harmonic Distortion (THD)	0.903	
	Calculated Efficiency (Output/Input)				83.79%	
50%	Set Output Current to	500	mA	Measured Input Power	7.15	W
	Measured Output Voltage	12.067	V	True Power Factor	0.497	
	Calculated Output Power	6.034	W	Total Harmonic Distortion (THD)	0.885	
	Calculated Efficiency (Output/Input)				84.38%	
25%	Set Output Current to	250	mA	Measured Input Power	3.62	W
	Measured Output Voltage	12.147	V	True Power Factor	0.48	
	Calculated Output Power	3.037	W	Total Harmonic Distortion (THD)	0.908	
	Calculated Efficiency (Output/Input)				83.89%	
				Average Active Mode Efficiency:	83.97%	
0%	Set the Output to No Load			Measured Input Power	0.06	W
				True Power Factor	0.473	

Power Curve

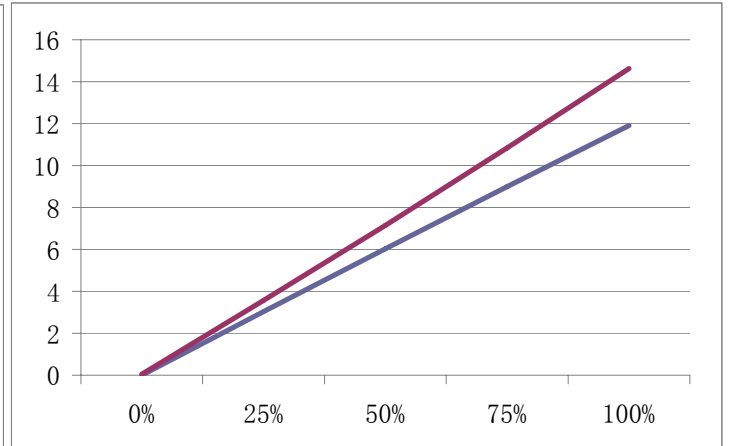
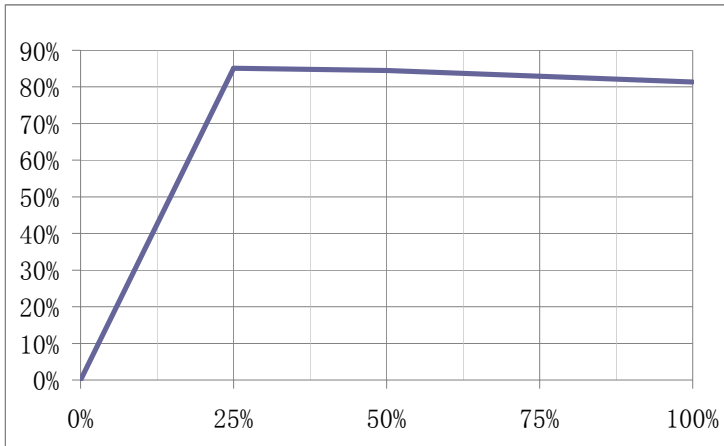

Label: